

Temperature Controller

KT SERIES



Temperature Controller

KT SERIES



KT4R series
(48 × 48 × 58.8 mm)
(1.890 × 1.890 × 2.315 in)

KT8R series
(48 × 96 × 58.8 mm)
(1.890 × 3.780 × 2.315 in)

KT9R series
(96 × 96 × 58.8 mm)
(3.780 × 3.780 × 2.315 in)

KT2 series
(48 × 24 × 98.5 mm)
(1.890 × 0.945 × 3.878 in)

KT7 series
(22.5 × 75 × 100 mm)
(0.886 × 2.953 × 3.937 in)

KT4H / KT4B series
(48 × 48 × 56 mm)
(1.890 × 1.890 × 2.205 in)



RoHS compliance

Extensive line-up with models to match application and space

Upgraded KT4, KT8 and KT9 models Improved visibility, operability and performance! **KT4R / KT8R / KT9R**

Smooth initial setting and setting adjustment

Operation startup can begin after using initial setting mode to enter the control values required before first use, and after entering values for items such as frequently used and frequently changed settings. Smooth operation is enabled at initial startup and after changing settings.

Built-in easy programming function

Easy programmed control made possible using nine-step setting procedure. By entering specific target values for each indicated period, freely selectable temperature control is possible.

Example: From start of programmed control

- ① Perform control so it becomes 200 °C 392 °F after 1 hour.
- ② Maintain 200 °C 392 °F until after 2 hours.
- ③ Perform control so it becomes 300 °C 572 °F after 30 minutes.

Step	1	2	3	4	5
SV (°C / °F)	200 392	200 392	300 572	300 572	0 32
Time	1:00	2:00	0:30	1:00	2:00
Wait (°C / °F)	10 50	0 32	10 50	0 32	0 32

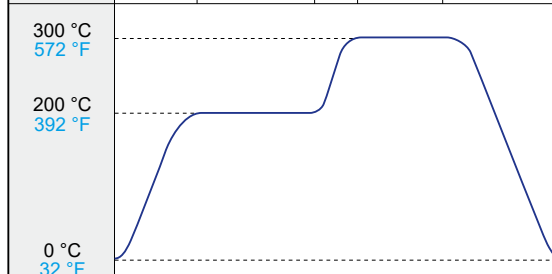

Fine control of heat capacity

Sampling period rate half (1/2 times) from previous model: high speed 125 ms processing implemented. With twice the responsiveness, it is possible to more finely carry out control, for example, of the heat capacity.

Built-in rearing auto tuning function

The built-in rearing auto tuning function uses the step response method. From temperature rise behavior alone, it can calculate the PID constants. It is possible to calculate constants, even when auto tuning cannot be used to generate them. Because an ON/OFF operation is unnecessary, there is no disruption in control.

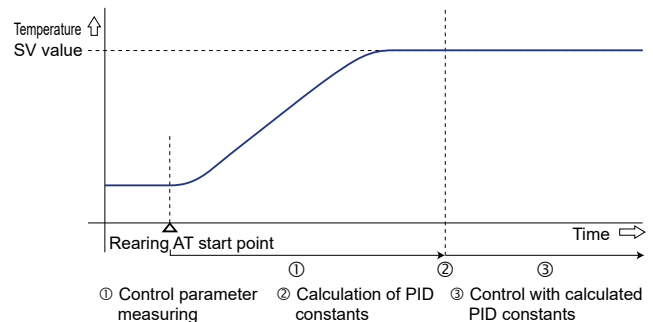

Other features

- Visibility and operability improved with large display and key size.
- Unit 60 mm 2.362 in approx. long: compact design saves space.
- With DC current output, can be used as simple signal converter.

Shared features of KT series

Multi-input sensors

Versatile thermocouple, RTD, DC voltage and DC current input for temperature detecting sensors.

Simple operation enables highly accurate temperature control

All required operations can be enabled by the front keys and highly accurate PID control mode ensures an input span of $\pm 0.2\%$.

DIN Rail mounting types are aligned taking global market demand into consideration **KT7**

The **KT7** series is equipped with DIN rail mounting complying to DIN standards. Furthermore, because its control panel is compact, the **KT7** series saves space.

Nine step pattern control possible **KT2**

For **KT2** series, despite DIN 48 × 24 size, selection is possible of control with fixed set point and nine step pattern control.

Meets market demands for cost-effectiveness

The **KT** series offers both economy and high performance.

The **KT** series complies with UL / c-UL standard and CE marking

Improved visibility and ease of operation

More compact than before **KT4H / KT4B**

The **KT4H / KT4B** series features improved visibility with a process value (PV) character height of 12 mm **0.472 in** and an 11-segment display. Connectable to a PC, it offers a full range of control and communication functions.

Communication specification uses RS-485

(Modbus protocol) **Excluding KT8R / KT9R**

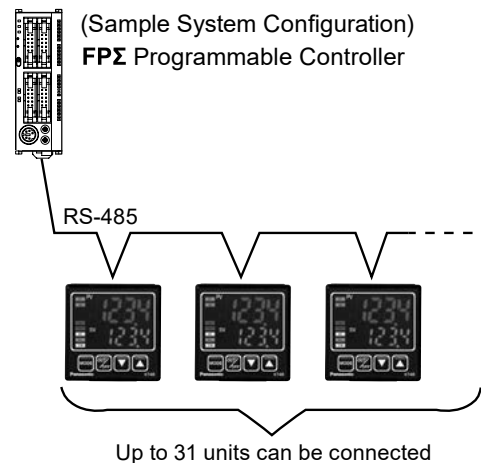

- Notes: 1) Only on type equipped with communications function.
2) In the configuration above, the FPΣ requires a communication cassette (**FPG-COM3**).
3) Modbus protocol is a communication protocol developed for PLCs by Modicon Inc.

KT Monitor

Available for download free of charge from our website. Use it to collect data from the **KT4H / KT4B** temperature controller.



■ Features

1. Parameters can be set from a PC.
2. Measurement data can be monitored from a PC.
3. Measurement data can be logged to a PC.

All data settings and temperature profile display

When free setting software (KT Monitor) and dedicated tool cable are used, you can edit data and so on easily.

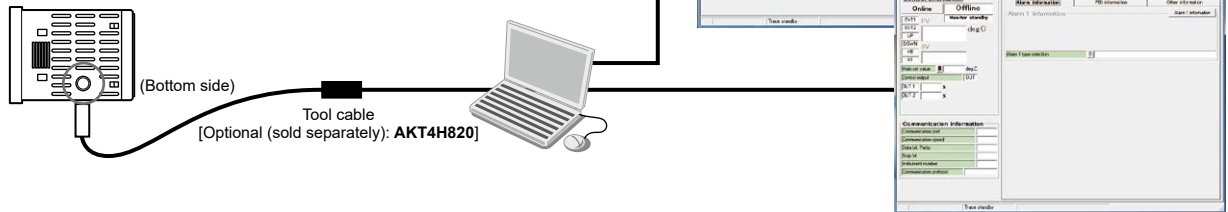

Please download the setting software (**KT Monitor**) from our website.

APPLICATIONS

Contributing to space saving, cost saving, and effort saving of various heater control systems.

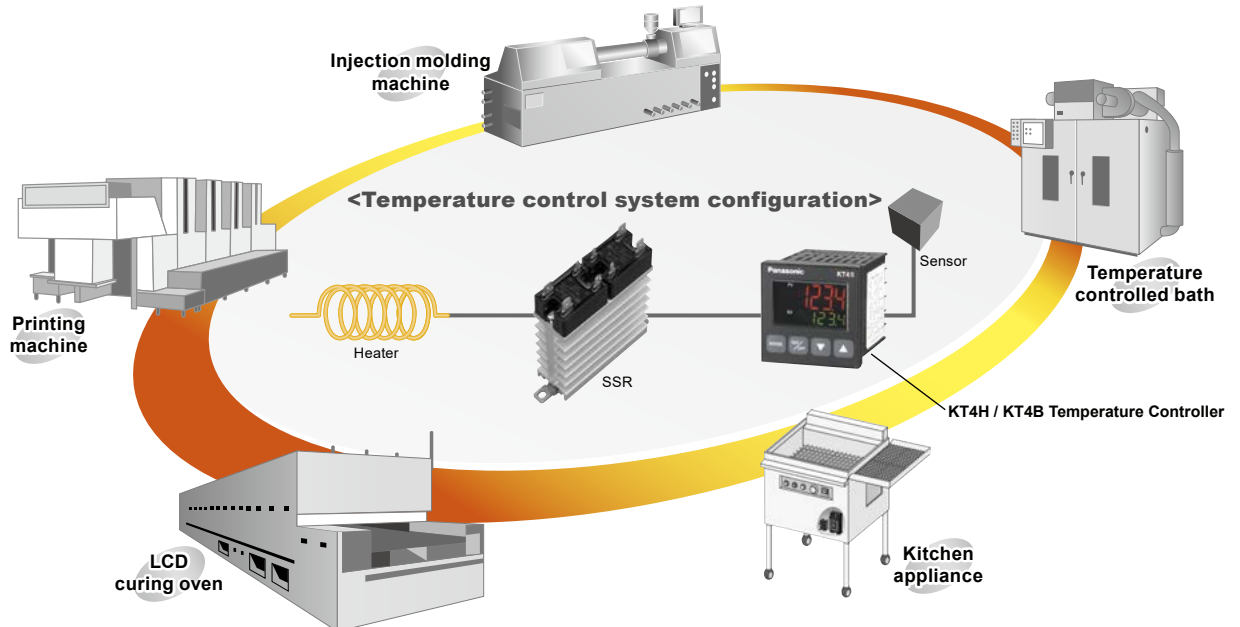

ORDER GUIDE

KT2 series (Ash grey)

Base model	Power supply	Sensor input	Control output	Alarm output	Heating / cooling	Heater burnout	Communication function	Description					
AKT2	1							48 × 24 × 98.5 mm 1.890 × 0.945 × 3.878 in					
								100-240 V AC	Must be specified				
	2						24 V AC/DC						
			1						Multi-input (Thermocouple, RTD, DC voltage and DC current)				
									1	Relay contact output 1a 250 V AC 3 A	Must be specified		
									2	Non-contact voltage output (Voltage output for SSR drive)			
									3	DC current output			
									2	0	0	Blank	When both heating / cooling and communication functions are not added Relay contact output (alarm 1) Can be used Open collector output (alarm 2) Can be used
									1	1	0	Blank	When only heating / cooling function is added Relay contact output (alarm 1) Cannot be used Open collector output (alarm 2) Can be used
									1	0	0	1	When only communication function is added Relay contact output (alarm 1) Can be used Open collector output (alarm 2) Cannot be used
0									1	0	1	When both heating / cooling and communication functions are added Relay contact output (alarm 1) Cannot be used Open collector output (alarm 2) Cannot be used	

Notes: 1) When heating / cooling is selected, alarm output 1 cannot be used.

2) When the communication function is selected, alarm output 2 cannot be used.

Model No. search method

Example: Basic functions + optional functions (Heating / cooling: relay contact output + communication function)

- For KT2 series, the option function is only the following 4 patterns.

AKT2*1*200 Blank AKT2*1*1001

AKT2*1*110 Blank AKT2*1*0101

- Model No.: AKT21110101

Options Please refer to p.8.

Product name	Model No.
Shunt resistor (for current input)	AKT4810
Terminal cover	AKT2801

Note: When current input is specified, a shunt resistor (sold separately) is required.

KT4R series (Black)

Base model	Power supply	Sensor input	Control output	Alarm output	Heating / cooling	Heater burnout	Communication function	Model No.						
AKT4R	1 (100-240 V AC)	1 (multi-input)	1 (Relay contact)	1 (1 point)	0 (Not available)	0 (Not available)	Blank (Not available)	AKT4R111100						
				2 (2 points) (Note)			1 (serial communication RS-485)	AKT4R1111001						
				2 (Non-contact voltage)			1 (1 point)	Blank (Not available)	AKT4R111200					
							2 (2 points)	1 (serial communication RS-485)	AKT4R1112001					
													Blank (Not available)	AKT4R112100
													1 (serial communication RS-485)	AKT4R1121001
													Blank (Not available)	AKT4R112200
													1 (serial communication RS-485)	AKT4R1122001

Note: Using EV2 assigned settings, use for heating and cooling control is possible.

Options Please refer to p.8.

Product name	Model No.
Terminal cover	AKT4H801

Product name	Model No.
Mounting frame	For KT4R / KT4H / KT4B AKW4822

Note: Since a shunt resistor is built in, a separately sold shunt resistor is not required when DC current input is specified.

ORDER GUIDE

KT8R series (Black)

Base model	Power supply	Sensor input	Control output	Alarm output	Heating / cooling	Heater burnout	Model No.
AKT8R	1 (100-240 V AC)	1 (Multi-input)	1 (Relay contact)	1 (1 point)	0 (Not available)	0 (Not available)	AKT8R111100
				2 (2 points) (Note)			AKT8R111200
			2 (Non-contact voltage)	1 (1 point)			AKT8R112100
				2 (2 points) (Note)			AKT8R112200

Note: Using EV2 assigned settings, use for heating and cooling control is possible.

Options Please refer to p.8.

Product name	Model No.
Terminal cover	AKT8R801

Product name	Model No.
Mounting frame	AKW8822

Note: Since a shunt resistor is built in, a separately sold shunt resistor is not required when DC current input is specified.

KT9R series (Black)

Base model	Power supply	Sensor input	Control output	Alarm output	Heating / cooling	Heater burnout	Model No.
AKT9R	1 (100-240 V AC)	1 (Multi-input)	1 (Relay contact)	1 (1 point)	0 (Not available)	0 (Not available)	AKT9R111100
			3 (DC current)	1 (1 point)			AKT9R113100

Options Please refer to p.8.

Product name	Model No.
Terminal cover	AKT9R801

Note: Since a shunt resistor is built in, a separately sold shunt resistor is not required when DC current input is specified.

KT7 series (Ash grey)

Base model	Power supply	Sensor input	Control output	Alarm output	Heating / cooling	Heater burnout	Communication function	Description
AKT7	1	1	1	1	1	0	1	22.5 × 75 × 100 mm 0.886 × 2.953 × 3.937 in
								100-240 V AC
	2							24 V AC/DC
	1							Multi-input (Thermocouple, RTD, DC voltage and DC current)
	1							Relay contact output 1a 250 V AC 3 A
	2							Non-contact voltage output (Voltage output for SSR drive)
	3							DC current output
	1							Open collector output (alarm output 1)
	0							Not available (without heating/cooling function)
	0							Not available
	1							5 A (not available for the DC current type) Open collector output
	2							10 A (not available for the DC current type) Open collector output
	3							20 A (not available for the DC current type) Open collector output
	4							50 A (not available for the DC current type) Open collector output
Blank	Not available							
1	Available							

Notes: 1) CT1 or CT2 for current transformer is provided as an accessory when heater burnout alarm function is added.
2) When adding alarm output 1 and heater burnout alarm at the same time, it'll be common output.

Model No. search method

Example: When the additional function (heater burnout alarm: 10 A) is added on to the basic function
• Model No.: **AKT7111102**

Options Please refer to p.8.

Product name	Model No.
Shunt resistor (for current input)	AKT4811
DIN rail	ATA48011
Fastening plate	ATA4806

Note: When current input is specified, a shunt resistor (sold separately) is required.

ORDER GUIDE

KT4H series (Ash grey)

Base model	Power supply	Sensor input	Control output	Alarm output	Heating / cooling	Heater burnout	Communication function	Description							
AKT4H	1 2	1	1	1	0	0	Blank	100-240 V AC							
								24 V AC/DC							
	1							1	1	1	0	0	0	Multi I/O Thermocouple, RTD, DC current and DC voltage	
														Relay contact output 1a 250 V AC 3 A	
														Non-contact voltage output (Voltage output for SSR drive)	
														DC current output Heater burnout alarm: not possible	
														1 point (1a)	
														2 points (1a + 1a) Heating/cooling control output: not possible	
														Not available	
														1 0	Relay contact output Heater burnout alarm: not possible
														2 0	Non-contact voltage (Voltage output for SSR drive) Heater burnout alarm: not possible
														0	Not available
														1 or 2 0 3	Single phase 20 A (Heater burnout alarm not supported when control output is DC current type / Not supported when heating/cooling control is selected)
														1 or 2 0 4	Single phase 50 A (Heater burnout alarm not supported when control output is DC current type / Not supported when heating/cooling control is selected)
														1 or 2 0 5	Three phase 20 A (Heater burnout alarm not supported when control output is DC current type / Not supported when heating/cooling control is selected)
														1 or 2 0 6	Three phase 50 A (Heater burnout alarm not supported when control output is DC current type / Not supported when heating/cooling control is selected)
														Blank	Not available
1	Serial communication RS-485														
2	Contact input														

Notes: 1) CT1 or CT2 for current transformer is provided as an accessory when heater burnout alarm is added.

2) Under some conditions, option functions (shaded items) may not be available; please check the "Description" of the above table for non-functioning circumstances.

Model No. search method

Example: When the optional functions (heating/cooling: relay contact, communication function: serial communication) are added on to the basic function

• Model No.: **AKT4H111101**

KT4B series (Black)

Base model	Power supply	Sensor input	Control output	Alarm output	Heating / cooling	Heater burnout	Communication function	Model No.	
AKT4B	1 (100-240 V AC)	1 (Multi-input)	1 (Relay contact)	1 (1 point)	0 (Not available)	0 (Not available)	Blank (Not available)	AKT4B111100	
							1 (Serial communication)	AKT4B1111001	
				2 (2 points)			Blank (Not available)	AKT4B111200	
							1 (Serial communication)	AKT4B1112001	
				2 (Non-contact voltage)			1 (1 point)	Blank (Not available)	AKT4B112100
								1 (Serial communication)	AKT4B1121001
			2 (2 points)				Blank (Not available)	AKT4B112200	
				1 (Serial communication)			AKT4B1122001		
			3 (DC current)	1 (1 point)			Blank (Not available)	AKT4B113100	
							1 (Serial communication)	AKT4B1131001	
				2 (2 points)			Blank (Not available)	AKT4B113200	
							1 (Serial communication)	AKT4B1132001	

Notes: 1) Please inquire if you need specifications not included in the model numbers above. On our website, it is easy to find products by model number selection or by searching for specifications.

2) Use RS-485 for serial communication.

Options (Common for KT4H and KT4B) Please refer to p.8.

Product name	Model No.
Shunt resistor (for current input)	AKT4810
Terminal cover	AKT4H801
Tool cable	AKT4H820
Mounting frame	For KT4R / KT4H / KT4B AKW4822

Note: When current input is specified, a shunt resistor (sold separately) is required.

Setting software

Product name	Description	Remark
KT Monitor	Editing of all types of data and file saving Monitoring of indicated value and saving of log files	Available for download free of charge from our website.

Note: Please download the user manual from our website.

OPTIONS

Product name		Model No.	Product name		Model No.
Terminal cover	For KT2	AKT2801	Current transformer (CT) (Note 2)	CT1 (for 5, 10 and 20 A)	Current transformer CT1 or CT2 is included when heater burnout alarm function is added.
	For KT4R	AKT4H801		CT2 (for 50 A)	
	For KT8R	AKT8R801	Tool cable (for KT4H / KT4B)		AKT4H820
	For KT9R	AKT9R801	Mounting frame	For KT4R / KT4H / KT4B	AKW4822
For KT4H / KT4B	AKT4H801	For KT8R		AKW8822	
Shunt resistor (for current input) (Note 1)	For KT2 / KT4H / KT4B	AKT4810	DIN rail	For KT7	ATA48011
	For KT7	AKT4811	Fastening plate	For KT7	ATA4806

Notes: 1) For **KT2**, **KT4H**, **KT4B** and **KT7**, when current input is specified, the shunt resistor (sold separately) is required.

2) Current transformer CT1 or CT2 is included (only with **KT7** and **KT4H**) when heater burnout alarm function is added.

RATING**Performance outline**

Item	Specifications						
	KT2	KT4R	KT8R	KT9R	KT7	KT4H / KT4B	
CE marking directive compliance	Low Voltage Directive, EMC Directive, RoHS Directive						
Size	48 × 24 mm 1.890 × 0.945 in	48 × 48 mm 1.890 × 1.890 in	48 × 96 mm 1.890 × 3.780 in	96 × 96 mm 3.780 × 3.780 in	22.5 × 75 mm 0.886 × 2.953 in	48 × 48 mm 1.890 × 1.890 in	
Rating power supply (Must be specified)	100-240 V AC 24 V AC/DC		100-240 V AC		100-240 V AC 24 V AC/DC		
Rating frequency	50/60 Hz						
Rating power consumption	5 VA approx.	8 VA approx.			6 VA approx.	8 VA approx.	
Rating Rating scale	Input type		Input range				
	Thermocouple	K	-200 to 1,370 °C (-320 to 2,500 °F) -199.9 to 400.0 °C (-199.9 to 750.0 °F)	-200 to 1,370 °C (-328 to 2,489 °F) -200.0 to 400.0 °C (-328.0 to 752.0 °F)	-200 to 1,370 °C (-328 to 2,489 °F)	-200 to 1,370 °C (-320 to 2,500 °F) -199.9 to 400.0 °C (-199.9 to 750.0 °F)	-200.0 to 400.0 °C (-320.0 to 750.0 °F)
		J	-200 to 1,000 °C (-320 to 1,800 °F)	-200 to 1,000 °C (-328 to 1,832 °F)	-200 to 1,000 °C (-328 to 1,832 °F)	-200 to 1,000 °C (-320 to 1,800 °F)	-200 to 1,000 °C (-320 to 1,800 °F)
		R	0 to 1,760 °C (0 to 3,200 °F)	0 to 1,760 °C (0 to 3,200 °F)	0 to 1,760 °C (0 to 3,200 °F)	0 to 1,760 °C (0 to 3,200 °F)	0 to 1,760 °C (0 to 3,200 °F)
		S	0 to 1,760 °C (0 to 3,200 °F)	0 to 1,760 °C (0 to 3,200 °F)	0 to 1,760 °C (0 to 3,200 °F)	0 to 1,760 °C (0 to 3,200 °F)	0 to 1,760 °C (0 to 3,200 °F)
		B	0 to 1,820 °C (0 to 3,300 °F)	0 to 1,820 °C (32 to 3,308 °F)	0 to 1,820 °C (32 to 3,308 °F)	0 to 1,820 °C (0 to 3,300 °F)	0 to 1,820 °C (0 to 3,300 °F)
		E	-200 to 800 °C (-320 to 1,500 °F)	-200 to 800 °C (-328 to 1,472 °F)	-200 to 800 °C (-328 to 1,472 °F)	-200 to 800 °C (-320 to 1,500 °F)	-200 to 800 °C (-320 to 1,500 °F)
		T	-199.9 to 400.0 °C (-199.9 to 750.0 °F)	-200.0 to 400.0 °C (-328.0 to 752.0 °F)	-200.0 to 400.0 °C (-328.0 to 752.0 °F)	-199.9 to 400.0 °C (-199.9 to 750.0 °F)	-200.0 to 400.0 °C (-320.0 to 750.0 °F)
		N	-200 to 1,300 °C (-320 to 2,300 °F)	-200 to 1,300 °C (-328 to 2,372 °F)	-200 to 1,300 °C (-328 to 2,372 °F)	-200 to 1,300 °C (-320 to 2,300 °F)	-200 to 1,300 °C (-320 to 2,300 °F)
	PL-II	0 to 1,390 °C (0 to 2,500 °F)	0 to 1,390 °C (32 to 2,534 °F)	0 to 1,390 °C (32 to 2,534 °F)	0 to 1,390 °C (0 to 2,500 °F)	0 to 1,390 °C (0 to 2,500 °F)	
	C (W / Re5-26)	0 to 2,315 °C (0 to 4,200 °F)	0 to 2,315 °C (32 to 4,199 °F)	0 to 2,315 °C (32 to 4,199 °F)	0 to 2,315 °C (0 to 4,200 °F)	0 to 2,315 °C (0 to 4,200 °F)	
	RTD	Pt100	-200 to 850 °C (-300 to 1,500 °F) -199.9 to 850.0 °C (-199.9 to 999.9 °F)	-200 to 850 °C (-328 to 1,562 °F) -200.0 to 850.0 °C (-328.0 to 1,562.0 °F)	-200 to 850 °C (-328 to 1,562 °F)	-200 to 850 °C (-300 to 1,500 °F) -199.9 to 850.0 °C (-199.9 to 999.9 °F)	-200 to 850 °C (-320 to 1,500 °F) -200.0 to 850.0 °C (-320.0 to 1,500.0 °F)
		JPt100	-200 to 500 °C (-300 to 900 °F) -199.9 to 500.0 °C (-199.9 to 900.0 °F)	-200 to 500 °C (-328 to 932 °F) -200 to 500.0 °C (-328.0 to 932.0 °F)	-200 to 500 °C (-328 to 932 °F)	-200 to 500 °C (-300 to 900 °F) -199.9 to 500.0 °C (-199.9 to 900.0 °F)	-200 to 500 °C (-320 to 900 °F) -200.0 to 500.0 °C (-320.0 to 900.0 °F)
	DC	Current	4 to 20 mA DC	-2,000 to 10,000	-2,000 to 10,000	-1,999 to 9,999 -199.9 to 999.9 -19.99 to 99.99 -1.999 to 9.999	-2,000 to 10,000
			0 to 20 mA DC				
		Voltage	0 to 1 V DC				
			0 to 10 V DC				
			1 to 5 V DC				
	0 to 5 V DC						
	<ul style="list-style-type: none"> • Scaling and change to the decimal point position is possible for DC current input and DC voltage input. • DC current input of KT2 / KT7 / KT4H / KT4B is supported with an externally connected 50 Ω shunt resistor (sold separately). 						
Sensor input	Thermocouple		K, J, R, S, B, E, T, N, PL-II, C (W / Re5-26) External resistor: 100 Ω or less (40 Ω or less external resistor for B input)				
	RTD		Pt100, JPt100 3-conductor system (Allowable input conductor resistance for each conductor: 10 Ω or less)				
	DC current		Input impedance: 50 Ω (For KT2 / KT7 / KT4H / KT4B , connect 50 Ω shunt resistor between input terminals.) Allowable input current: 50 mA or less (For KT2 / KT7 / KT4H / KT4B , when 50 Ω shunt resistor is used)				
	DC voltage		Input impedance: 1 MΩ or more, Allowable input voltage: 5 V or less, Allowable signal source resistance: 2 kΩ or less				
			Input impedance: 100 kΩ or more, Allowable input voltage: 15 V or less, Allowable signal source resistance: 100 Ω or less				
Control output	Relay contact		1a 3 A 250 V AC (at resistive load), 1 A 250 V AC (at inductive load cos φ = 0.4), Electrical life: 100,000 times				
	Non-contact voltage (Voltage output for SSR drive)		12 ⁺² V DC, Max. load current: 40 mA (with short circuit protection circuit)			12 V DC ±15 % Max. load current: 40 mA (with short circuit protection circuit)	
	DC current		4 to 20 mA DC, Load resistance: Max. 550 Ω				
	Alarm output 1 (EV1)		Relay contact 1a 3 A 250 V AC (Resistive load) 1a 1 A 250 V AC (cosφ=0.4) Electrical life: 100,000 times			Open collector control capacity: 24 V DC 0.1 A (Max.) Relay contact 1a: Control capacity: 3 A 250 V AC (Resistive load), Electrical life: 100,000 times	
Alarm output 2 (EV2)		Open collector: 0.1 A 24 V DC		Same as Alarm output 1		Not available	Same as Alarm output 1
Control method		PID action (with auto-tuning function), PI action, PD action (with manual reset function), P action (with manual reset function), ON / OFF action					
Target temperature setting		Primary setting / secondary setting (switched by external terminal)			Primary setting / secondary setting / third setting / fourth setting (switched by external terminal)		
Program control function		1 pattern, 9-step setting is possible (However, make function selection setting of either control with fixed set point or program control.)					
Indication accuracy	Thermocouple		Within ± (0.2 % + 1 digit) of each input span or within ±2 °C (4 °F) whichever is greater However, R or S input; within ±6 °C (12 °F) in the range of 0 to 200 °C (32 to 392 °F) B input, range of 0 to 300 °C (32 to 572 °F): accuracy is not guaranteed K, J, E, T, and N input, less than 0 °C (32 °F): within ± (0.4 % ±1 digit) of input span				
	RTD		Within ± (0.1 % + 1 digit) of each input span or ±1 °C (2 °F) whichever is greater				
	DC current and DC voltage		Within ± (0.2 % + 1 digit) of each input span				
Sampling period		250 ms		125 ms		250 ms	

RATING

Performance outline

Item	Specifications							
	KT2	KT4R	KT8R	KT9R	KT7	KT4H / KT4B		
Hysteresis (ON / OFF)	Thermocouple and RTD: 0.1 to 100.0 °C (°F) DC current and DC voltage: 1 to 1,000 (The decimal point place follows the selection)	Thermocouple and RTD: 0.1 to 1,000.0 °C (°F) DC current and DC voltage: 1 to 10,000 (The decimal point place follows the selection)			Thermocouple and RTD: 0.1 to 100.0 °C (°F) DC current and DC voltage: 1 to 1,000 (The decimal point place follows the selection)			
Proportional band	For sensor input range, DC current and DC voltage: 0.0 to 110.0 %	Input without decimal point: 0 to Input span Input with decimal point: 0.0 to Input span DC current and DC voltage: 0.0 to 1,000.0 %			For sensor input range, DC current and DC voltage: 0.0 to 110.0 %	0 to 1,000 °C (0 to 2,000 °F) Input with decimal point: 0.0 to 1,000.0 °C (0.0 to 1,000.0 °F) DC current and DC voltage: 0.0 to 100.0 %		
Integral time	0 to 1,000 seconds	0 to 3,600 seconds			0 to 1,000 seconds			
Derivative time	0 to 300 seconds	0 to 1,800 seconds			0 to 300 seconds			
Proportional cycle	1 to 120 seconds							
Allowable voltage fluctuation	When 100-240 V AC: 85-264 V AC, When 24 V AC/DC: 20-28 V AC/DC							
Insulated resistance	500 V DC, Min. 10 MΩ							
Breakdown voltage	Between input terminal and power terminal Between output terminal and power terminal 1.5 kV AC for 1 min.							
Malfunction vibration	10 to 55 Hz (1 cycle/min.), single amplitude (KT7: double amplitude): 0.35 mm 0.014 in (10 min. on 3 axes)							
Breakdown vibration	10 to 55 Hz (1 cycle/min.), single amplitude (KT7: double amplitude): 0.75 mm 0.030 in (1 hour on 3 axes)							
Malfunction shock	X, Y and Z each direction for 5 times 98 m/s ²							
Breakdown shock	X, Y and Z each direction for 5 times 294 m/s ²							
Ambient temperature	0 to +50 °C 32 to +122 °F	-10 to +55 °C 14 to +131 °F			0 to +50 °C 32 to +122 °F			
Ambient humidity	35 to 85 % RH (No condensation)							
Mass	120 g approx.	110 g approx.	160 g approx.	220 g approx.	150 g approx.	120 g approx.		
Waterproof	IP66 (applicable only to the front panel subject to rubber gasket employed)				None	IP66 (applicable only to the front panel subject to rubber gasket employed)		
Display character height	PV: 8.7 mm 0.342 in SV: 8.7 mm 0.342 in (PV / SV switching display)	PV: 12.4 mm 0.488 in SV: 8.8 mm 0.346 in	PV: 14 mm 0.551 in SV: 14 mm 0.551 in	PV: 14 mm 0.551 in SV: 14 mm 0.551 in	PV: 7.4 mm 0.291 in SV: 7.4 mm 0.291 in	PV: 12 mm 0.472 in SV: 6 mm 0.236 in		
Option functions	Heating / Cooling control	Relay contact	Relay contact: 1a 3 A 250 V DC (at resistive load)			Using EV2 assigned setting, use for heating and cooling control is possible.	None	1a Control capacity: 3 A 250 V AC (at resistive load), Electrical life: 100,000 times
		Non-contact voltage	_____					12 V DC ±15 %, Max. 40 mA (with short circuit protection circuit)
	Heater burnout alarm output	_____					Open collector control capacity: 24 V DC 0.1 A (Max.)	For KT4H only: Specify either single phase 20 A, single phase 50 A, 3 phases 20 A, or 3 phases 50 A for rated heater current. Setting accuracy: within ±5 % of rated heater current. Relay contact: 1a 3 A 250 V AC (at resistive load), Electrical life: 100,000 times
Communication function	Please refer below to "COMMUNICATION PERFORMANCE OUTLINE". (Not available with KT8R / KT9R)							
Accessories	Mounting frame / Mounting bracket	Included with controller				_____	Included with controller	
	Terminal cover	Sold separately				_____	Sold separately	
	Rubber gasket	Included with controller				_____	Included with controller	

Note: Tool port: **KT4H** and **KT4B** only; cannot be used simultaneously with serial interface C-MOS level serial communication (option). This port can only be used with the tool cable (**AKT4H820**).

Communication performance outline

Item	Specifications		
	KT2 / KT7	KT4H / KT4B	KT4R
Communication method	Half-duplex		
Communication speed	Select 2,400, 4,800, 9,600 or 19,200 bps using key operation.	Select 9,600, 19,200 or 38,400 bps using key operation.	
Synchronous method	Asynchronous		
Protocol	Modbus (RTU, ASCII)	Modbus (RTU, ASCII), MEWTOCOL (Slave)	
Coding	Binary / ASCII		
Error correcting	Command resending		
Error detection	Parity check and check sum		
Data structure	Start bit: 1 Data bit: 7 Parity: Even parity Stop bit: 1		Start bit: 1 Data bit: 7, 8 (For Modbus RTU: 8 only) Parity: Even / Odd / None Stop bit: 1 or 2
Interface	EIA RS-485 compliant		
Number of nodes	31		
Maximum communication distance	1,000 m 3,280.840 ft (cable resistance must be within 50 Ω)		

EXTERNAL CONNECTION DIAGRAM

KT2 series

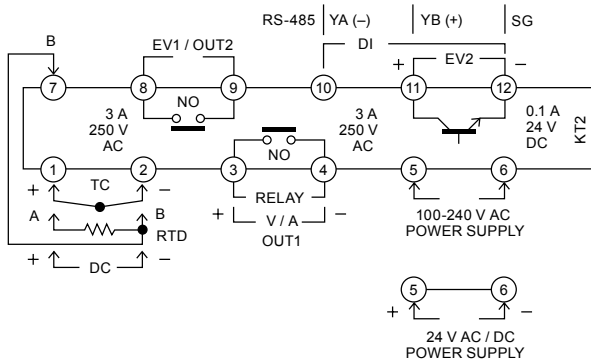

- TC: Input terminal for thermocouple
- RTD: Input terminal for the resistance temperature detector
- DC: Input terminal for DC current or DC voltage
For DC current input, connect a separately sold reception resistor (50 Ω) between the input terminals
- OUT1: Output terminal for the control output or heating output (optional: heating / cooling control)
- POWER SUPPLY: Power supply terminal
- EV1 / OUT2: Output terminal for alarm output 1 or cooling output (optional: heating / cooling control)
- EV2: Output terminal for alarm output 2
- DI: Input terminal for DI input (There are three types of DI input, SV1 / SV2 external switching function, OUT / OFF (RUN / STOP) external switching function, and timer function)
- RS-485: Communication terminal for serial communication.

KT4R series

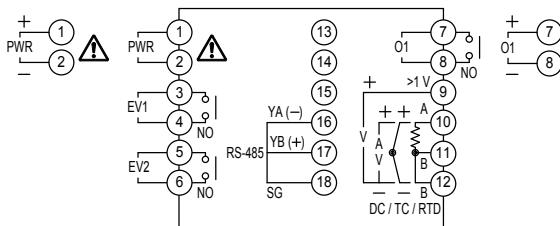

- PWR: Power supply voltage 100-240 V AC or 24 V AC / DC (Ensure correct polarity when using DC in AC / DC 24 V.)
- EV1: Alarm output 1
- EV2: Alarm output 2 (optional)
- O1: Control output 1
- TC: Thermocouple input
- RTD: Resistance temperature detector input
- DC: DC voltage input or DC current input
- RS-485: Serial communication RS-485

KT8R / KT9R series

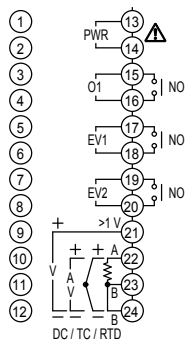

- PWR: Power supply voltage 100-240 V AC
- EV1: Alarm output 1
- EV2: Alarm output 2 (optional)
- O1: Control output 1
- TC: Thermocouple input
- RTD: Resistance temperature detector input
- DC: DC voltage input or DC current input

KT7 series

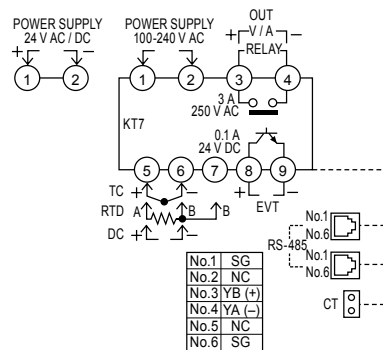

- POWER SUPPLY: Power supply
- OUT: Control output
- RELAY: Relay contact output
- V / A: DC voltage output / DC current output
- EVT: Alarm output [Outputs when alarm, loop fault alarm or heater burnout alarm (optional) goes ON.]
- TC: Thermocouple
- RTD: Resistance temperature detector
- DC: DC current or DC voltage
- RS-485: Serial communication
- CT: CT input

KT4H / KT4B series

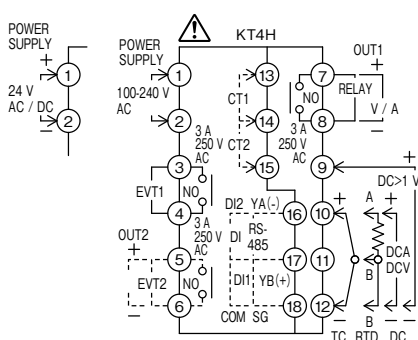

- POWER SUPPLY: Power supply voltage
- EVT1: Alarm output 1
- EVT2: Alarm output 2 (optional) or heater burnout alarm output (optional)
- OUT1: Control output or heating output (optional)
- OUT2: Cooling output (optional)
- TC: Thermocouple input
- RTD: Resistance temperature detector input
- DC: DC current input (DCA) or DC voltage input (DCV)
(For DC voltage input, + side connection terminal differs depending on the voltage. Also, for DC current input, connect shunt resistor between No. ⑩ and ⑫ terminals.)
- CT1: Current transformer input 1 (optional: for single phase and three phases)
- CT2: Current transformer input 2 (optional: for three phases)
- DI: Contact input (optional)
- RS-485: Serial communication RS-485 (optional)

COMMUNICATION FUNCTION CONNECTION DIAGRAM (PLC Connection Diagram)

KT2 / KT4R series

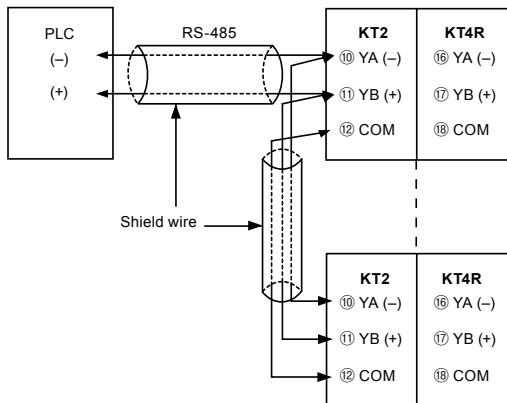

KT7 series

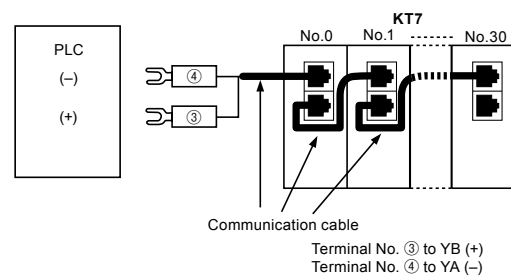

Notes: 1) Terminating resistors (Terminators)

The **KT** series has a built-in pull-up resistor or pull-down resistor, which serves as the terminating resistor. For this reason, do not connect the terminating resistor on the communication line.

2) Please use a RJ-11 6 polarized type modular connector.

Please use a cable that is suitable for a modular connector. (Only **KT7** series)

KT4H / KT4B series

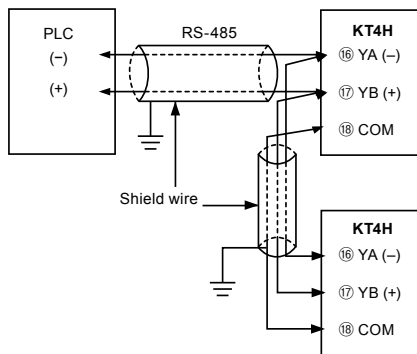

Notes: 1) Shield wire

To prevent current flow along shield sections, ground one end of the shield wire.

(If both ends of the shield section are grounded, a closed circuit with the earth will form and electricity flowing through the shield wire will cause increased susceptibility to noise.)

2) Terminating Resistors (Terminators)

The **KT4H / KT4B** series has a built-in pull-up resistor or pull-down resistor. For this reason, do not connect the terminating resistor on the communication line.

PRECAUTIONS FOR PROPER USE

Mounting

KT2 series

Please install vertically in order to satisfy the IP66 specification for dust and splash proofing.
The possible control panel plate thickness for installation is between 1 to 10 mm **0.039 to 0.394 in.**

- ① Insert the unit from the front of the control panel.
- ② Insert the mounting frame until that the two edges make contact with the panel.
- ③ Tighten the screw and then turn it 3/4 of a turn after the edge of the screw reaches the panel.

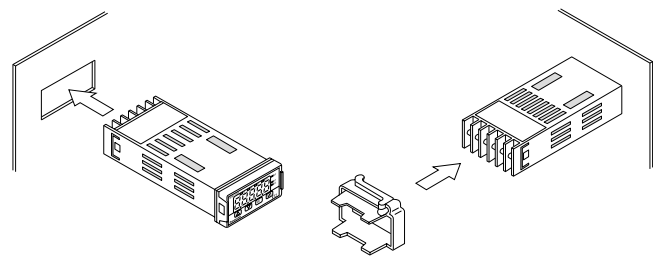

KT4R series

Please install to a rigid, irregularity-free flat surface in order to satisfy the IP66 specification for dust and splash proofing.
Panel thickness for installation: 1 to 5 mm **0.039 to 0.197 in**

- ① Insert the unit from the front of the control panel.
- ② Insert the mounting frame until that the edges make contact with the panel and tighten the screw.
Fix by rotating screws one full turn after contact of screw tip and panel.
Apply tightening torque of 0.15 N·m.

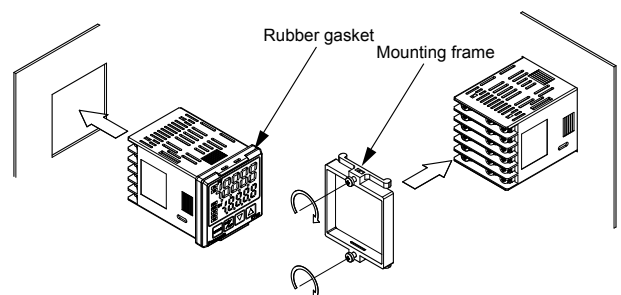

PRECAUTIONS FOR PROPER USE

Mounting

KT8R / KT9R series

Please install to a rigid, irregularity-free flat surface in order to satisfy the IP66 specification for dust and splash proofing. Panel thickness for installation: 1 to 7 mm **0.039 to 0.276 in**

- ① Insert the controller from the front of the control panel.
- ② Attach the screw type mounting brackets by the holes at the top and bottom of the case and secure the controller in place with the screws.

Apply tightening torque of 0.1 N·m.

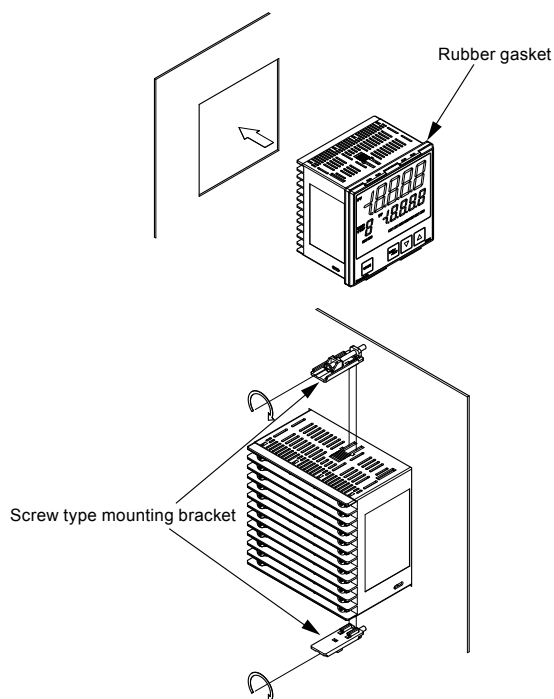

KT7 series

• DIN rail mounting

- ① Hook (A) of the **KT7** series controller on the upper side of the DIN rail.
- ② Making the (A) part of the **KT7** series controller as a support, fit the lower part of the **KT7** series controller to the DIN rail. **KT7** series controller will be completely fixed to the DIN rail with a “click” sound.

Recommended DIN rail: Model No. **ATA48011**

Recommended fastening plate: Model No. **ATA4806**

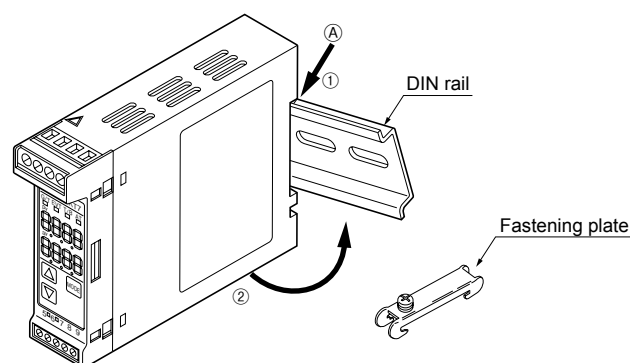

KT4H / KT4B series

Please install vertically in order to satisfy the IP66 specification for dust and splash proofing.

The possible control panel plate thickness for installation is between 1 to 5 mm **0.039 to 0.197 in**.

- ① Insert the unit from the front of the control panel.
- ② Push the mounting frame fully into contact with the panel and tighten the screws. (Screw tightening torque: 0.05 N·m to 0.06 N·m)

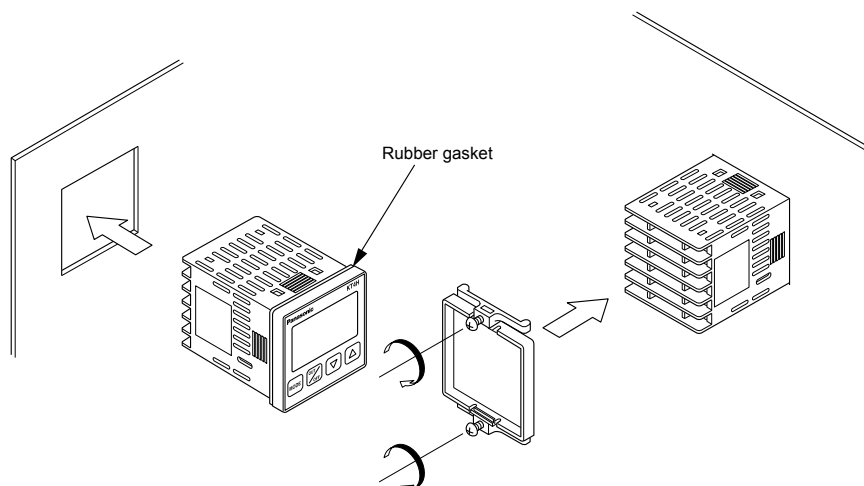

PRECAUTIONS FOR PROPER USE

Part description

KT2 series

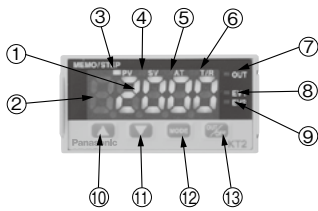

- ① PV/SV display (Red).....Indicates the process value (PV) and setting value (SV).
During setting mode, characters and setting value of the setting item are indicated in turn.
- ② MEMO/STEP display (Green).....Indicates the memory number during fixed value control. Indicates step number during program control.
- ③ PV indicator (Red).....Lights up when the input value is indicated.
- ④ SV indicator (Green).....Lights up when main setting value is indicated.
- ⑤ AT indicator (Yellow).....Flashes during auto-tuning (AT).
- ⑥ T/R indicator (Yellow).....Flashes during serial communication (Lit while sending data, Unlit while receiving data).
- ⑦ OUT indicator (Green).....Lights up when control output or OUT1 (heating side) output (optional: heating / cooling control) is ON.
For DC current output type, it flashes corresponding to the manipulated variable in a 0.25 second cycle.
- ⑧ EV1 indicator (Red).....Lights up when alarm output 1 or OUT2 (cooling side) output (optional: heating / cooling control) is ON.
- ⑨ EV2 indicator (Red).....Lights up when alarm output 2 is ON.
- ⑩ Increase keyIncreases the numeric value.
- ⑪ Decrease keyDecreases the numeric value.
- ⑫ Mode keySelects the setting mode or registers the setting value.
By pressing the mode key, the setting value or selected value can be registered.
- ⑬ OUT/OFF keyThe control output OUT / OFF or program control RUN / STOP can be switched.

KT4R series

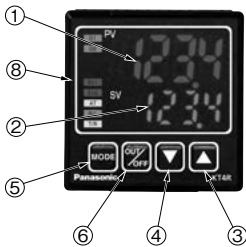

KT8R series

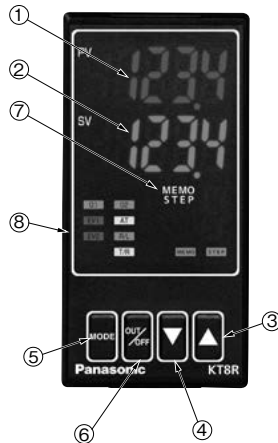

- ① PV display.....Indicates the process value (PV).
- ② SV display.....Indicates the setting value (SV).
- ③ Increase keyIncreases the numeric value.
- ④ Decrease keyDecreases the numeric value.
- ⑤ Mode keySelects the setting mode or registers the setting value.
- ⑥ OUT/OFF keyThe control output ON / OFF, auto / manual control function or program control can be switched. (Not available in **KT7** series)
- ⑦ STEP/MEMO displayIndicates the step number (program control) and set value memory number. (for **KT8R** and **KT9R**)
- ⑧ Action indicators (Not available in **KT7** series)
 - O1.....Lights up when control output 1 is ON.
Lights up when heating control output (optional) is ON.
For DC power output type, it flashes corresponding to the manipulated variable in a 125 ms cycle.
 - O2.....Lights up when cooling control output (optional) is ON.
 - EV1.....Lights when alarm output 1 is ON.
 - EV2Lights when alarm output 2 (optional) is ON.
 - ATFlashes during auto-tuning or auto-reset.
 - T/R.....Lights during serial communication (optional) TX output. (for **KT4R** only)

KT9R series



KT7 series

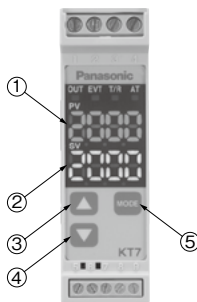

Note: Color selection is the same for each size.

KT4H / KT4B series

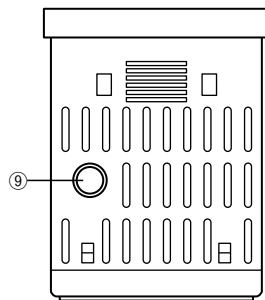
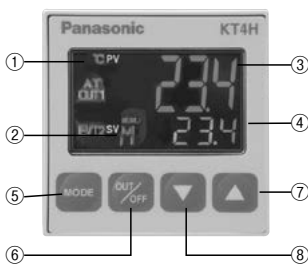

(Bottom side)

- ① Action indicators (backlight: Orange)
 - °F / °CLights respectively when temperature unit °F / °C is selected.
 - T/R.....Lights during serial communication (optional) TX output.
 - AT.....Flashes during auto-tuning or auto-reset.
 - OUT1.....Lights when control output is ON or heating output (optional) is ON.
For DC current output type, it flashes corresponding to the manipulated variable in 0.25 second cycles.
 - OUT2.....Lights when cooling output (optional) is ON.
 - EVT1Lights when alarm output 1 is ON.
 - EVT2Lights when alarm output 2 (optional) is ON or heater burnout alarm output (optional) is ON.
 - LOCK.....Lights when lock 1, lock 2 or lock 3 is selected.
- ② MEMO display.....Indicates the set value memory number. (backlight: Green)
- ③ PV display.....Indicates the process value (PV). (backlight: Red / Orange / Green)
- ④ SV display.....Indicates the set value (SV). (backlight: Green)
- ⑤ Mode keySelects the setting mode and registers the set value.
- ⑥ OUT/OFF keyThe control output ON / OFF or auto / manual control function can be switched.
- ⑦ Increase keyIncreases the numeric value.
- ⑧ Decrease keyDecreases the numeric value.
- ⑨ Tool connector.....By connecting the dedicated cable, the following operations can be conducted from the external computer.
 - Reading and setting of SV, PID and various set values
 - Reading of PV and action status
 - Function change

PRECAUTIONS FOR PROPER USE

Notes on site selection

This controller is intended to be used in the following environment. (IEC 61010-1)

- Overvoltage category II and Pollution degree 2
- Mount the controller in a place with:
 - A minimum of dust, and an absence of corrosive gases.
 - No flammable, explosive gases.
 - Few mechanical vibrations or shocks.
 - No exposure to direct sunlight, an ambient temperature of 0 to +50 °C **32 to +122 °F** (For **KT4R / KT8R / KT9R**: -10 to +55 °C **14 to +131 °F**) that does not change rapidly. (When installing inside a panel, make particular allowance for heat dissipation. Avoid installation in situations such as above equipment that generates heat.)
- Locations in which temperature rapidly changes may cause condensation.
- Locations or atmospheres in which benzene, thinners, alcohol, or other organic solvents are present, or in which ammonia, sodium hydroxide, or other strong alkaline substances may adhere.
- Locations susceptible to direct impact or the transmission of vibrations, or where splashing with water is possible.
- In the proximity of equipment in which large switching surges occur or near high-voltage cables, high-voltage equipment, power lines, power equipment, ham radio transmitters, or equipment containing these or similar devices.
- An ambient non-condensing humidity of 35 to 85 % RH.
- No large capacity electromagnetic switches or cables through which large current is flowing.
- No water, oil or chemicals or where the vapors of these substances can come into direct contact with the controller.

Notes on wiring

- The terminal block of **KT4R / KT8R / KT9R / KT4H / KT4B** series are designed to be wired from the left side (The terminal of **KT2** series are designed to be wired from the upper and lower direction). The lead wire must be inserted from the left side of the terminal, and fastened by the terminal screw. Use a wire-pressed terminal with insulation sleeve that fits to the M3 screw.

Wire-pressed terminal	Company name	Type name	Fastening torque
Fork type	NICHIFU Co., Ltd.	1.25Y-3	0.6 N·m
	J.S.T. Mfg. Co., Ltd.	VD1.25-B3A	
Round type	NICHIFU Co., Ltd.	1.25-3	Max. 1.0 N·m.
	J.S.T. Mfg. Co., Ltd.	V1.25-3	

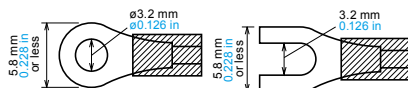

- Terminal screw fastening torque is 0.6 N·m to 1.0 N·m (for **KT4R / KT8R / KT9R / KT4H / KT4B** series). For **KT7** series by M3 screw is less than 0.5 N·m and by M2 screw is less than 0.25 N·m respectively.
- Use a thermocouple and compensating lead wire according to the sensor input specification of the controller.
- Use a 3-wire system of RTD according to the sensor input specification of the controller.

- This controller has no built-in power switch, circuit breaker and fuse. Therefore, it is necessary to install them in the circuit near the external controller. (Recommended fuse: Time-lag fuse, rating voltage 250 V AC, rating current 2 A)
- In the case of 24 V AC/DC power supply, do not confuse the polarity when it is DC.
- With the relay contact output type, use the relay externally according to the capacity of the load to protect the built-in relay contact.
- When wiring, keep input wire (Thermocouple, RTD, etc.) away from power source wire and load wire.
- Turn the power supply to the instrument off before wiring or checking. Working or touching the terminal with the power switched on may result in electric shock which could cause severe injury or death.
- Do not drop wire chips into the holes of vent when wiring.
- To prevent the controller from harmful effects of unexpected high level noise, it is recommended that a surge absorber be installed between the electromagnetic switch coils.

Notes on mounting

- Do not use excessive force while screwing in the mounting frame and mounting bracket of **KT4R / KT8R / KT9R / KT4H / KT4B** series. For **KT8R / KT9R** series, recommended torque is approximately 0.1 N·m. For **KT4H / KT4B** series, recommended torque is approximately 0.05 to 0.06 N·m. For **KT4R** series, recommended torque is approximately 0.15 N·m.
- When mounting the **KT7** series to the DIN rail, mount it in a lateral direction. Make sure a click is audible when fixed into place.

Optional heater burnout alarm output (for **KT7 / KT4H** series)

- This alarm output is not available for detecting heater current under phase control.
- Use the current transformer (CT) provided, and pass one lead wire of the heater circuit into the hole of CT.
- When wiring, keep CT wire away from power source wire and load wire to avoid external interference.
- In three phase installations for **KT4H** series, ensure that R, S and T are each connected to a 2-line CT that connects with CT1 [⑬ - ⑭] and CT2 [⑭ - ⑮] terminals.

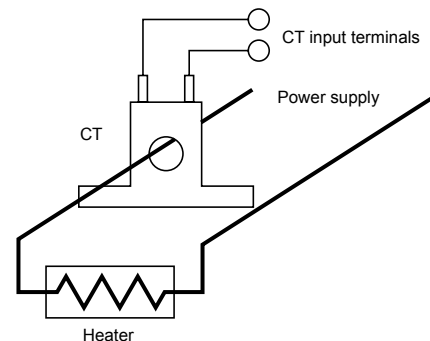

Please use rod terminals for the terminal portion of the **KT7** series.

We recommend terminals made by Phoenix Contact.

① to ④ are AI0.25-8YE, AI0.34-8TQ, AI0.5-8WH, AI0.75-8GY, AI1.0-8RD, and AI1.5-8BK.

⑤ to ⑨ are AI0.25-8YE, AI0.34-8TQ, and AI0.5-8WH. The screw tightening torque for ① to ④ should be less than 0.5 N·m and for ⑤ to ⑨ it should be less than 0.25 N·m. Make sure no screw is loose.

DIMENSIONS (Unit: mm in)

The CAD data can be downloaded from our website.

KT8R series

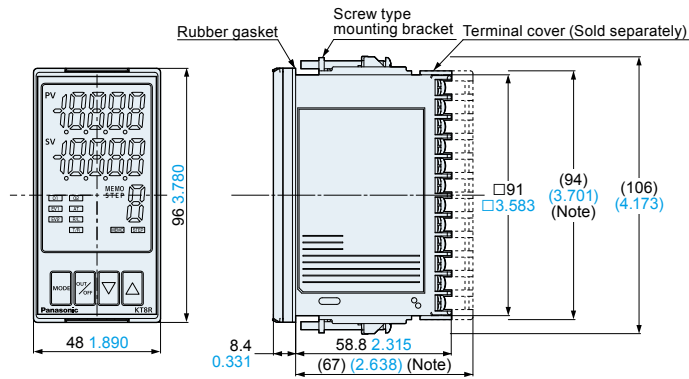

Panel cut-out dimensions

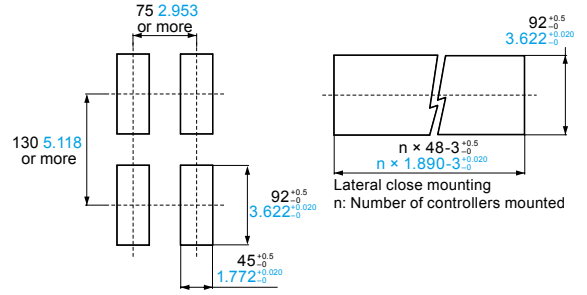

Note: Dimensions when terminal cover is fitted.

Tolerance: $\pm 1 \pm 0.039$

KT9R series

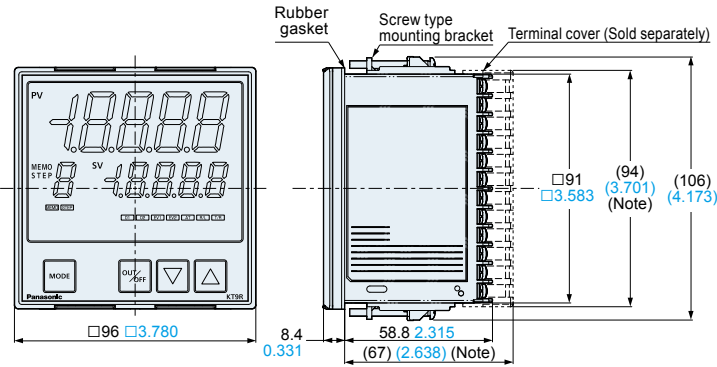

Panel cut-out dimensions

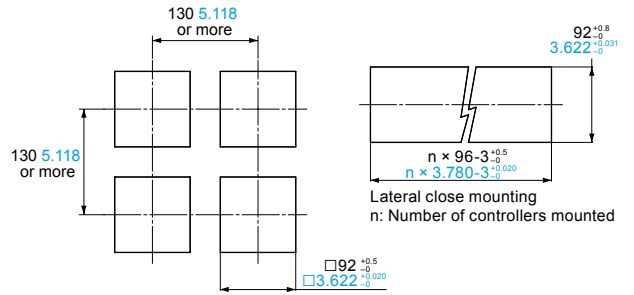

Note: Dimensions when terminal cover is fitted.

Tolerance: $\pm 1 \pm 0.039$

KT7 series

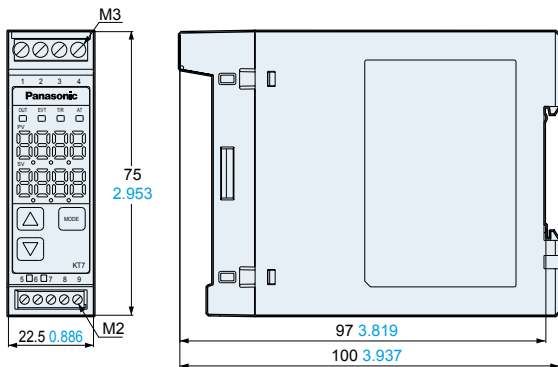

Note: The communications terminal is the modular jack on the bottom side of the controller.

Tolerance: $\pm 1 \pm 0.039$

KT4H / KT4B series

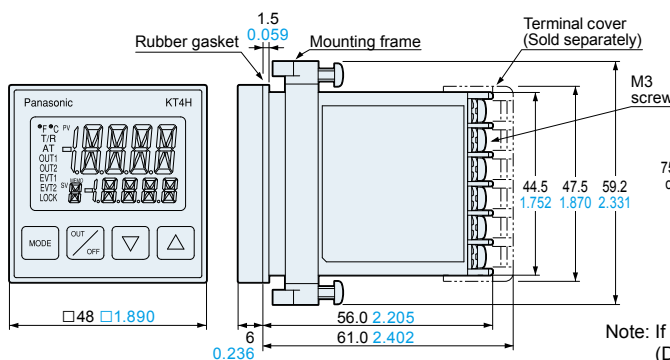

Panel cut-out dimensions

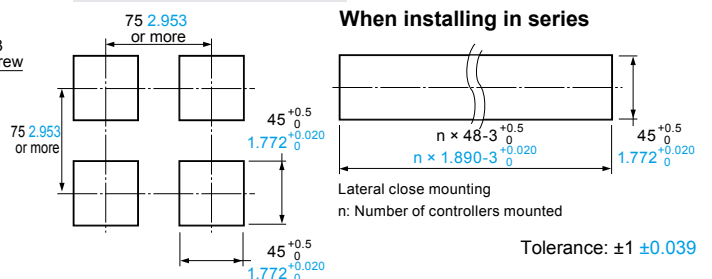

Note: If longitudinal or lateral close mounting is used for the controller, IP66 specification (Dust-proof/Drip-proof) may be compromised, and all warranties will be invalidated.

Tolerance: $\pm 1 \pm 0.039$

DIMENSIONS (Unit: mm in)

The CAD data can be downloaded from our website.

AKT2801 Terminal cover (for KT2)

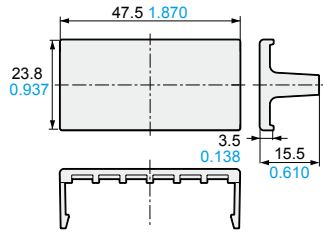

AKT8R801 AKT9R801 Terminal cover (for KT8R / KT9R)

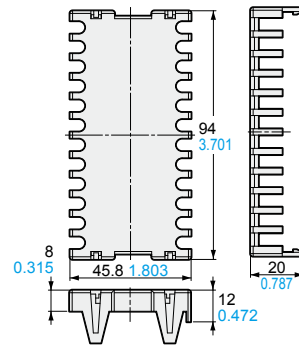

Note: 2 pieces of terminal cover of **AKT8R801** can be used as an **AKT9R801**.

AKT4H801 Terminal cover (for KT4H / KT4B / KT4R)

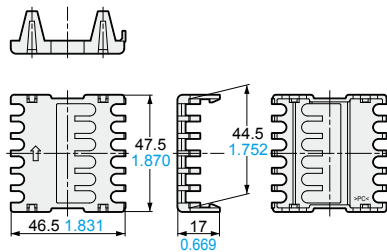

AKW4822 Mounting frame (for KT4R / KT4H / KT4B)

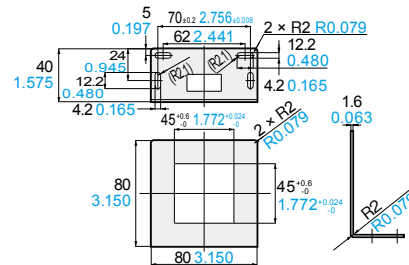

CT1 Current transformer (CT) (for 5, 10 and 20 A)

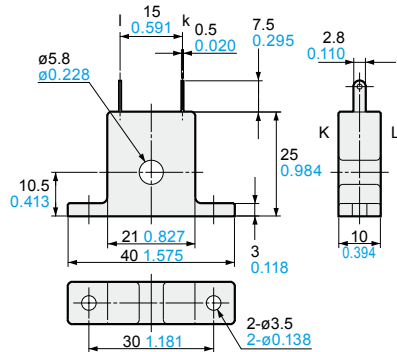

Note: Current transformer CT1 or CT2 is included (only with **KT7** and **KT4H**) when heater burnout alarm function is added.

AKW8822 Mounting frame (for KT8R)

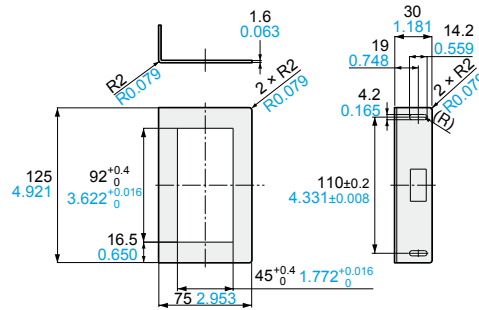

CT2 Current transformer (CT) (for 50 A)

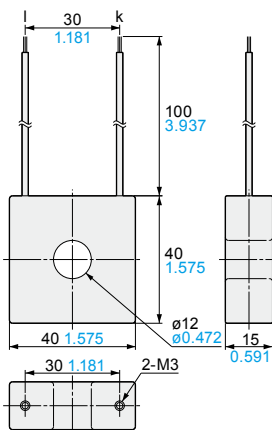

Note: Current transformer CT1 or CT2 is included (only with **KT7** and **KT4H**) when heater burnout alarm function is added.

AKT4H820 Tool cable (for KT4H / KT4B)

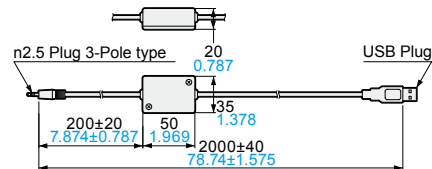

AKT4810 Shunt resistor (for KT2 / KT4H / KT4B)

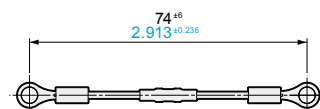

AKT4811 Shunt resistor (for KT7)

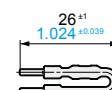

Disclaimer

The applications described in the catalog are all intended for examples only. The purchase of our products described in the catalog shall not be regarded as granting of a license to use our products in the described applications. We do NOT warrant that we have obtained some intellectual properties, such as patent rights, with respect to such applications, or that the described applications may not infringe any intellectual property rights, such as patent rights, of a third party.

Panasonic
INDUSTRY

Panasonic Industry Co., Ltd.

Industrial Device Business Division
7-1-1, Morofuku, Daito-shi, Osaka 574-0044, Japan
industrial.panasonic.com/ac/e/