

# Communication Unit for CC-Link SC-GU2-C



# SC-GU2-C



**Contributes to wire-saving, construction-saving, traceability, preventive maintenance, and more**

### To minimize life cycle cost

As the life cycle of equipment shortens year by year, controlling the cost at manufacturing or during usage has become an important subject. Panasonic Industry uses the communication unit for CC-Link **SC-GU2-C**, which makes the most use of open network for efficient and preventive maintenance as well as wire-saving and construction-saving.

Here is the solution for minimizing cost related to life cycle in equipment.

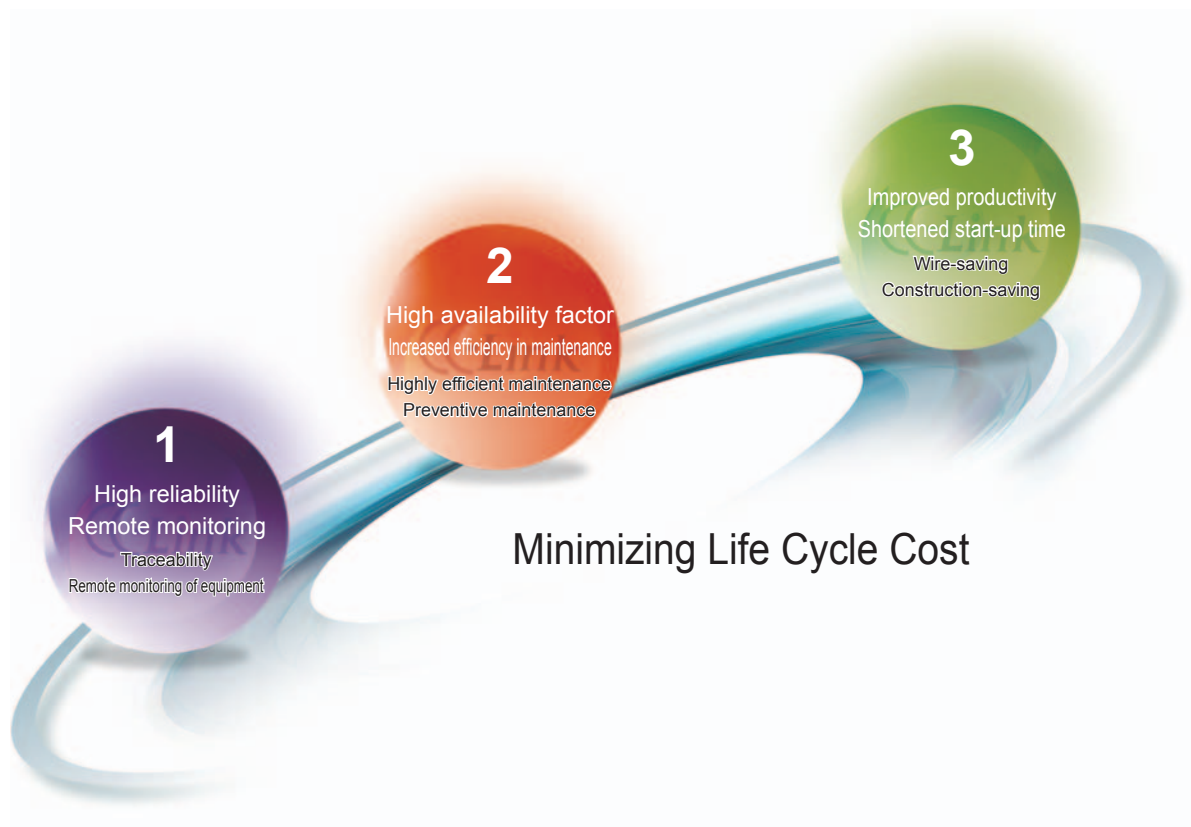

## Traceability

By keeping track of the sensor configurations at equipment start-up, any failure that may occur after equipment delivery can be eliminated in early stages.

### Before When a failure occurs

It is hard to identify as to what went wrong. Great numbers of man-hours are taken to check on the setting of each sensor one by one.

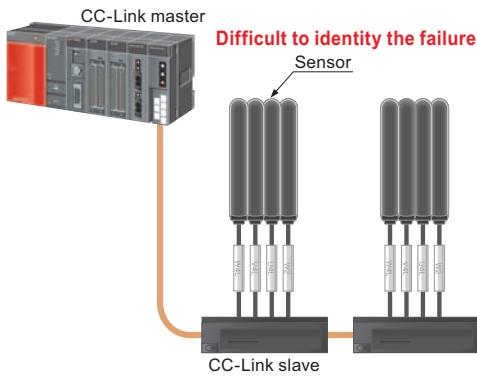

### After When a failure occurs

It is easy to identify as to what went wrong. By having the information of each sensor saved as "Configuration file", traceability is improved, and incorrect input or setting loss can be prevented.

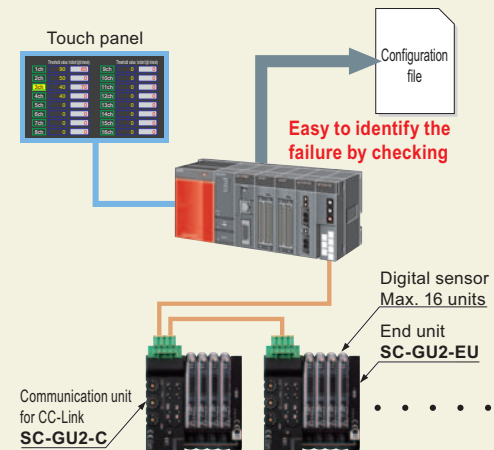

\* Maximum of 12 units including the FX-500 series can communicate optically.

## Remote monitoring of equipment

It is possible to check the sensor configurations through open network when a failure occurs in the equipment or production line, so that the on-site man-hours taken can be kept to the minimum.

### Before Current situation

Confirm on sensor condition via telephone or e-mail.



It takes time to confirm the configuration condition.

Worst comes worst, a trip down to the actual worksite is needed.

### After Adopting communication

Monitoring can be done via existing system or PC. Actions can be taken correctly and swiftly with accurate situations on hand.

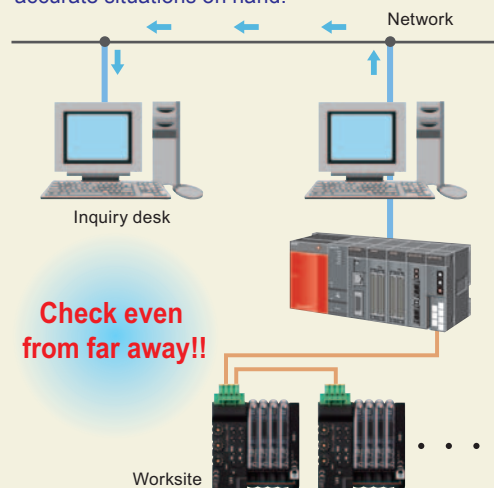

### Highly efficient maintenance

By having the configurations saved as “Configuration file” before equipment shipment, later on when it comes to exchanging the sensors, the configurations can be simply written in to CC-Link. Also, exchanges can be done easily with connection connectors without any extra tools.

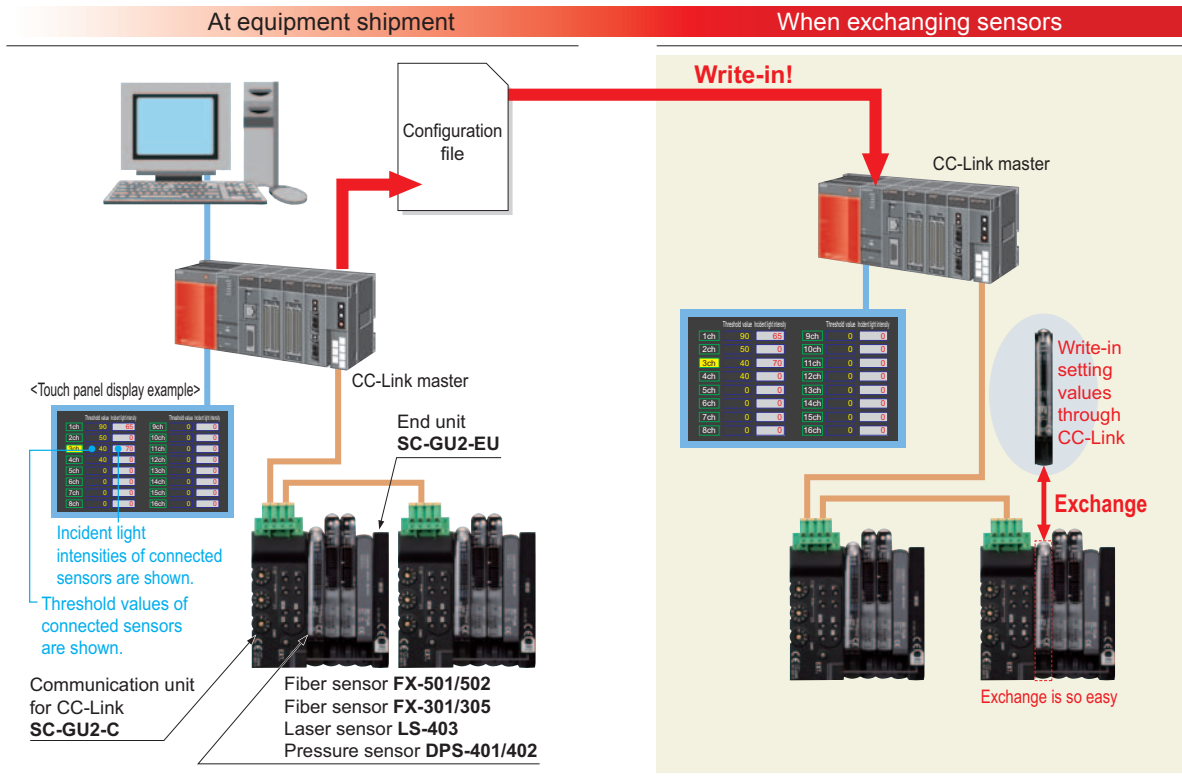

### Preventive maintenance

Take in digital data such as incident light intensity or pressure value of sensors and graph them out for preventive maintenance.  
(e.g.) Light attenuated due to dirt on fiber sensor.

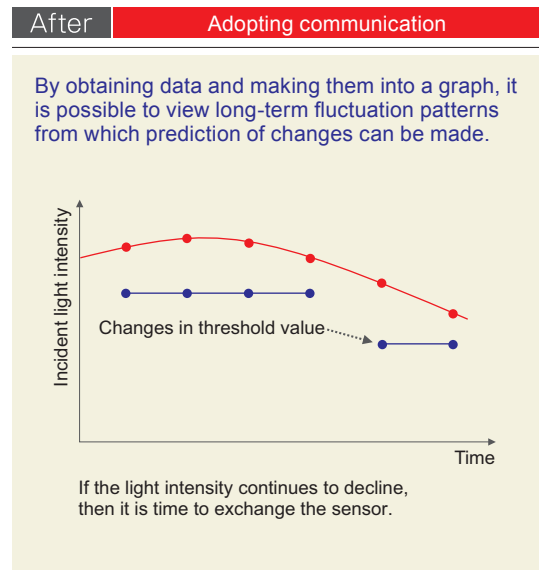

\* To make a graph, it is necessary to compose a ladder separately.

### Easy maintenance with the memory function

Settings of the connected digital sensors are stored in the **SC-GU2-C**. Setting data can be transmitted and restored to original status by just pressing the "Setting extension (EXT.)" key. Maintenance such as sensor replacement, etc., can be performed smoothly. It will also automatically check the settings stored in the **SC-GU2-C** and the settings for the digital sensor when the power is turned on. When the setting is different, memory function indicator will flash, and warning signal can be sent, preventing the equipment operating with settings changed.

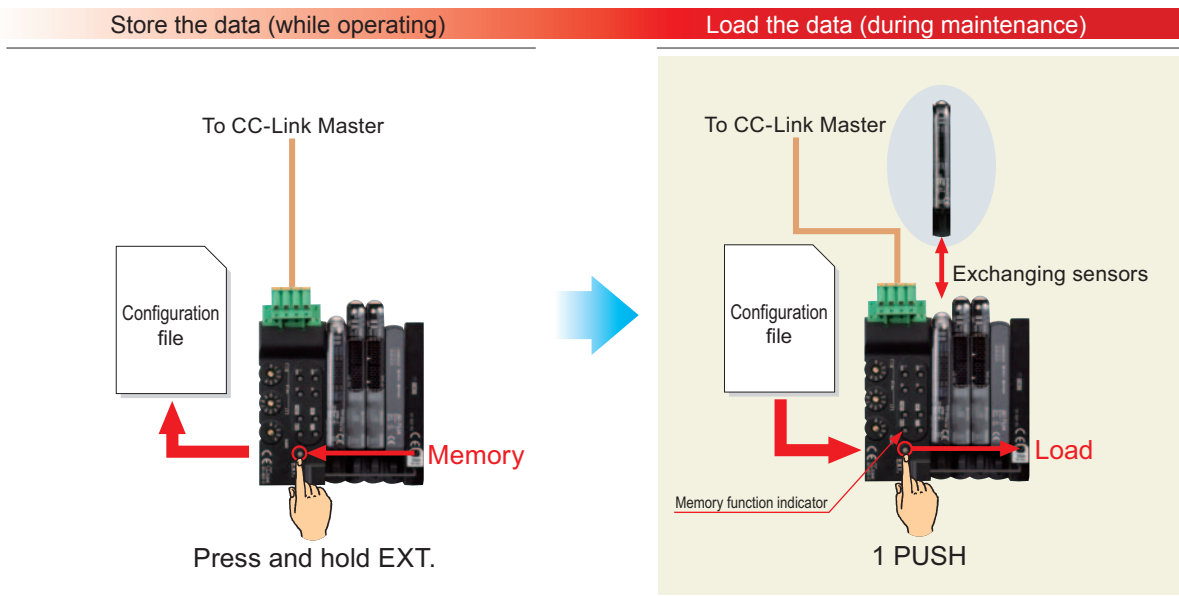

\* Memory function can be utilized with CC-Link communication by setting the flag in the remote register.

### Reduction of wiring, construction and space

Space for installing a CC-Link slave is eliminated. Cascade connection is simply done by connectors so that the time taken for wiring and construction can be cut down.

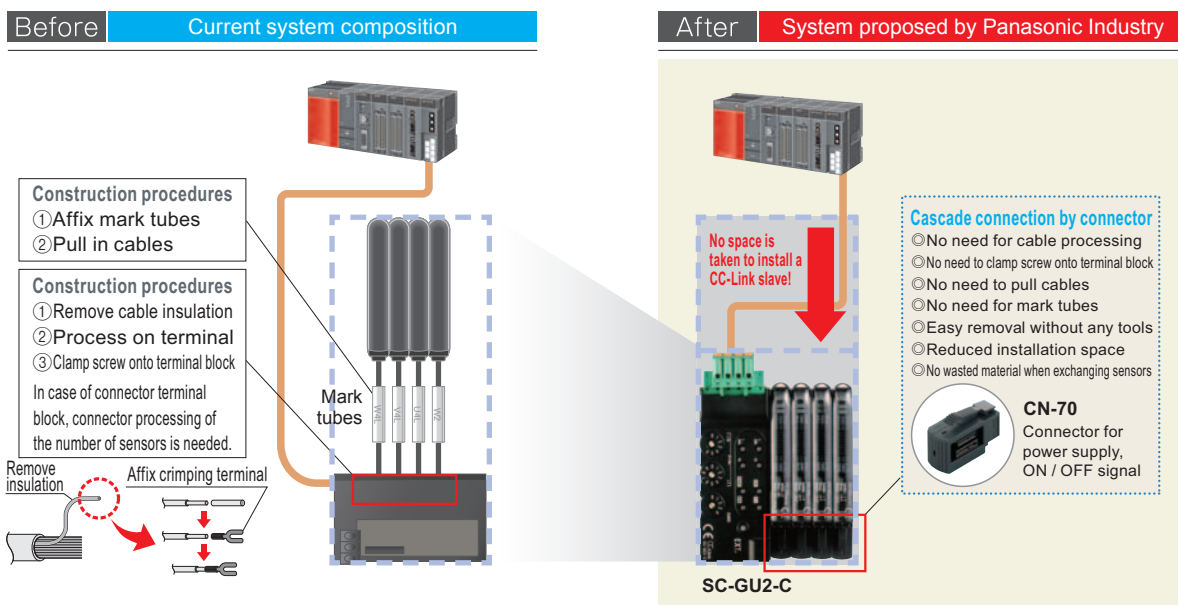

## Space saving with open unit setting

When you like to perform the process for every 1 byte (sensor input: For 8 units) to make the data control clear, of if you are planning to add sensors later, it is possible to set the open unit (sensor). Also with the conventional remote I/O, you needed installation space for 16 units, but this can save the installation space to minimum.

**Example: To divide 16 units to every 8 units, and create open unit for 3 units each**

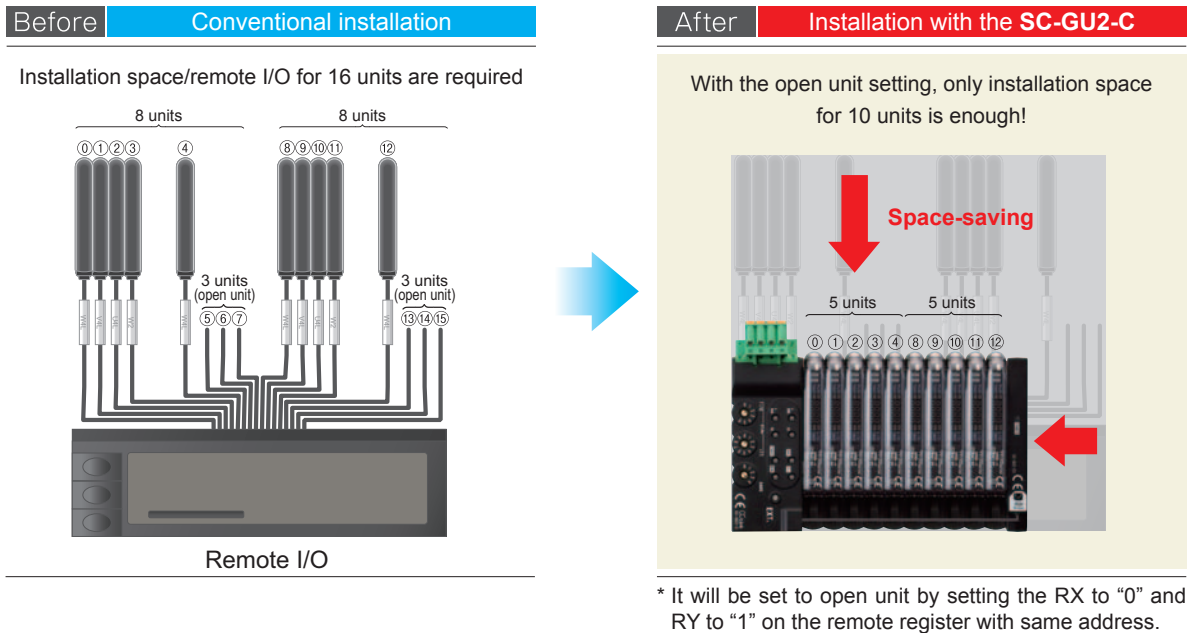

## Make use of spare channels

For sensors that cannot connect in cascade, connect a connector input extension unit **SC-T1JA**, **SC-T1J**, **SC-T8J** / a connector I/O mixed extension unit **SC-TP8J** to **SC-GU2-C** to enable cascade connection to save more wiring. **SC-T1JA** can also connect with sensors of analog input (1 to 5 V).

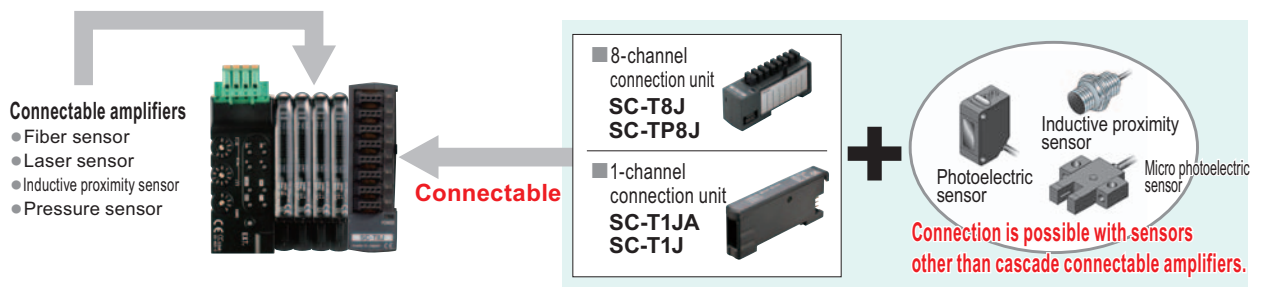

## Distributed installation is possible

Distributed installation of sensors is possible by using the plug-in sensor separate unit **SC-MIL-S** / sensor main unit **SC-MIL**. (However, only input for Output 1 (ON/OFF) can communicate. (Output 2 cannot be input.) Also, optical communication of current data and threshold value setting etc. are not possible.)

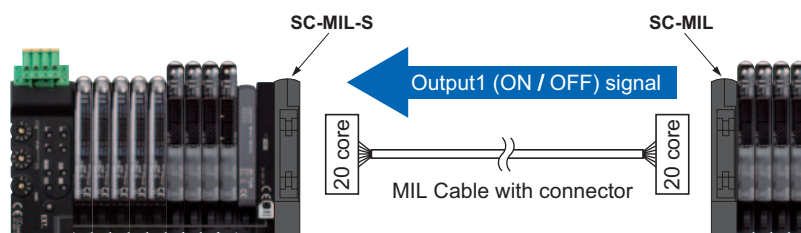

## SYSTEM COMPOSITION

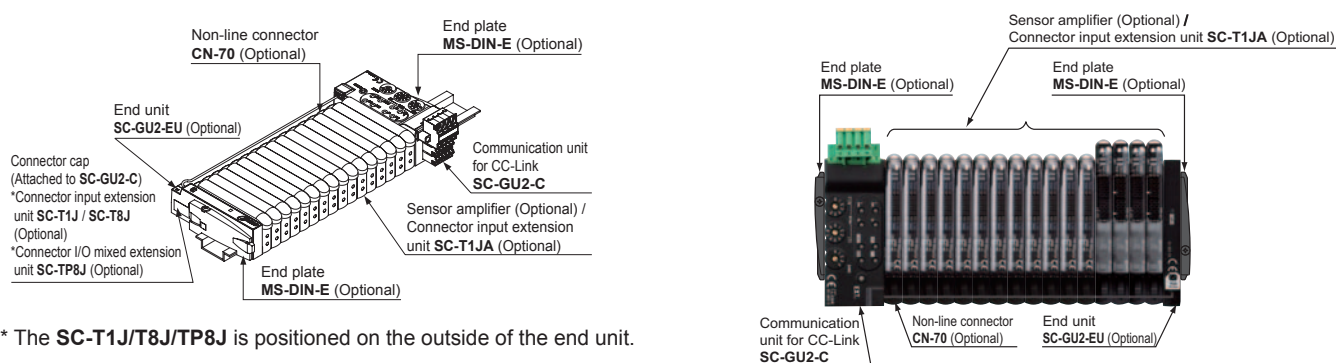

\* The SC-T1J/T8J/TP8J is positioned on the outside of the end unit.  
Transmits ON / OFF signal only.  
Does not respond to data communication.

## ORDER GUIDE

### Communication units

| Designation                    | Appearance | Model No. | Description   |
|--------------------------------|------------|-----------|---|
| Communication unit for CC-Link |            | SC-GU2-C  | This is a communication unit, which can convert the output signal of a sensor amplifier into communication data for CC-Link.        |
| End unit                       |            | SC-GU2-EU | This end unit can change and check the settings of sensor amplifiers that allow optical communication and monitor operation status. |

### Connector input extension units





| Designation                                  | Appearance | Model No. | Description   |
|--|------------|-----------|---|
| 1-channel connector input extension unit     |            | SC-T1JA   | This product can be connected with input devices such as sensors and switches. Also, the product can monitor by using 1 to 5 V analog voltage output, which is outputted by the input devices.<br>* When communicating the converted value from analog to digital, the end unit SC-GU2-EU should be used. |
|  |            | SC-T1J    | Allows the connection of input device, such as sensor or switch. Incorporates a power indicator and an input signal indicator (1 ch).   |
| 8-channel connector input extension unit     |            | SC-T8J    | Allows the connection of input devices, such as sensors or switches. Incorporates a power indicator and input signal indicators (8 ch).   |
| 8-channel connector I/O mixed extension unit |            | SC-TP8J   | Allows the connection of a variety of input and output devices. This unit does not contain input / output signal indicators.  |

### Plug-in sensor units (MIL connectors)

| Designation                  | Appearance | Model No. | Description   |
|------------------------------|------------|-----------|---|
| Plug-in sensor separate unit |            | SC-MIL-S  | Distributed installation by the MIL connector is possible by combining the plug-in sensor separate unit SC-MIL-S and the plug-in sensor main unit SC-MIL. |
| Plug-in sensor main unit     |            | SC-MIL    |   |



## ORDER GUIDE

### Optical communication compatible amplifier

| Type                    |   | Appearance  | Model No.        | Combined head        | Description                                      |
|-------------------------|---|---|------------------|----------------------|--|
| Digital fiber sensor    | FX-500 series                             |  | FX-501           | FT-□<br>FD-□         | NPN open-collector transistor                    |
|                         |   |   | FX-502           |                      | NPN open-collector transistor two outputs (Note) |
|                         | FX-300 series                             |  | FX-301           |                      | NPN open-collector transistor                    |
|                         |   |   | FX-305           |                      | NPN open-collector transistor two outputs (Note) |
| Digital laser sensor    |   |  | LS-501<br>LS-403 | LS-H□                | NPN open-collector transistor                    |
| Digital pressure sensor | For combined pressure / negative pressure |  | DPS-401          | DPH-101□<br>DPH-103□ | NPN open-collector transistor two outputs (Note) |
|                         | For positive pressure                     |   | DPS-402          | DPH-102□             |  |



Note: To receive the output signal from the Output 2, it is required to perform optical communication by simultaneously using the end unit **SC-GU2-EU**.

### Options

| Designation        | Appearance  | Model No.       | Description  |
|--------------------|---|-----------------|--|
| Non-line connector |  | <b>CN-70</b>    | This one-touch connector is used to connect the following devices to <b>SC-GU2-C</b> : The <b>FX-500/300/311/400</b> fiber sensor, the <b>LS-401/403</b> laser sensor, digital pressure sensor <b>DPS-401/402</b> , the <b>GA-311</b> compact inductive proximity sensor, etc. |
| End plate (Note)   |  | <b>MS-DIN-E</b> | After installing <b>SC-GU2-C</b> , sensor amplifier, <b>SC-GU2-EU</b> etc. in cascade on a DIN rail, these end plates clamp the units into place on both sides. Be sure to use this product.<br><b>Two pcs. per set</b>  |

Note: Commercially available DIN rail stopper can also be used.

### Others

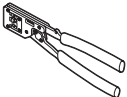
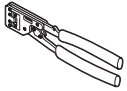
| Designation                              | Appearance  | Model No.   | Description   |
|--|---|---|---|
| 4-pin type snap male connector           |  | <b>SL-CP1 (White)</b><br><b>10 pcs. per set</b>         | For 0.08 to 0.2 mm <sup>2</sup><br>(Conductor cross-section area)<br>Wire dia.: ø0.7 to ø1.2 mm<br><b>ø0.028 to ø0.047 in</b> |
|  |  | <b>SL-CP2 (Black)</b><br><b>10 pcs. per set</b>         | For 0.3 mm <sup>2</sup><br>(Conductor cross-section area)<br>Wire dia.: ø1.1 to ø1.6 mm<br><b>ø0.043 to ø 0.063 in</b>        |
|  |  | <b>SL-CP3 (Greenish blue)</b><br><b>10 pcs. per set</b> | For 0.5 mm <sup>2</sup><br>(Conductor cross-section area)<br>Wire dia.: ø1.7 to ø2.5 mm<br><b>ø0.067 to ø0.098 in</b>         |
| Male / female connector exclusive pliers |  | <b>SL-JPC</b>   | Snap female connector and snap male connector ( <b>SL-CP1, CP2</b> ) can be connected in one grip.                            |
| <b>SL-CP3</b> exclusive pliers           |  | <b>SL-JPE</b>   | 4-pin type snap male connector ( <b>SL-CP3</b> ) can be connected in one grip.  |

Snap male connectors are utilized to connect input devices to both the 1-channel connector input extension unit **SC-T1J**, the 8-channel connector input extension unit **SC-T8J**, and the 8-channel connector I/O mixed extension unit **SC-TP8J**.  
**SC-T1J** includes one **SL-CP1**.



## ORDER GUIDE

### Others

| Designation        | Model No.                          | Description  |   |
|--------------------|------------------------------------|--|---|
| Input connector    | <b>CN-EP1</b><br>5 pcs. per set    | For 1 ch connector input unit (analog communication unit) <b>SC-T1JA</b> | Input connector is utilized to connect input devices to the 1-channel connector input unit (analog communication unit) <b>SC-T1JA</b> . <b>SC-T1JA</b> includes one <b>CN-EP1</b> .   |
| Index seals        | <b>SC-MA1</b><br>10 sheets per set | For 8 ch connector input unit <b>SC-T8J</b> and <b>SC-TP8J</b>           | An identifier for each connector should be marked on each seal, then the seals should be applied to the numbering plates attached to the 8-channel connector input extension unit <b>SC-T8J</b> and 8-channel connector I/O mixed extension unit <b>SC-TP8J</b> . <b>SC-T8J</b> and <b>SC-TP8J</b> includes one <b>SC-MA1</b> . |
| Connector end caps | <b>SC-PK</b><br>8 pcs. per set     |  | Utilized to protect the unconnected ends of connectors of 8-channel connector input extension unit <b>SL-T8J</b> and 8-channel connector I/O mixed extension unit <b>SC-TP8J</b> .  |

### Input connector

- **CN-EP1**

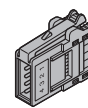

### Index seals

- **SC-MA1**

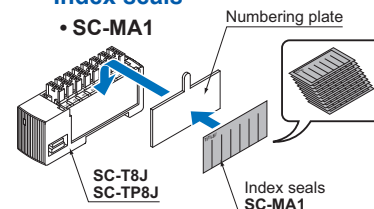

### Connector end caps

- **SC-PK**

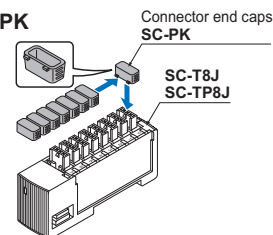

## SPECIFICATIONS

### Communication unit for CC-Link

| Designation                          | Communication unit for CC-Link |   |                  |                  |                   |                     |
|--------------------------------------|--------------------------------|---|------------------|------------------|-------------------|---------------------|
| Item                                 | Model No.                      | <b>SC-GU2-C</b>   |                  |                  |                   |                     |
| Applicable sensor amplifier (Note 2) |                                | Sensor amplifiers (NPN output type) that can connect to non-line connector <b>CN-70</b> (optional) ( <b>FX-500/300/311/410</b> series, <b>LS-401/403</b> , <b>DPS-401/402</b> , <b>GA-311</b> )   |                  |                  |                   |                     |
| Number of connectable units          |                                | Max. 16 units (sensor amplifiers / input units / I/O extension units) per <b>SC-GU2-C</b> (Maximum of 12 units including the <b>FX-500</b> series can communicate optically)  |                  |                  |                   |                     |
| Supply voltage                       |                                | 24 V DC $\pm 1\%$ Ripple P-P 10 % or less   |                  |                  |                   |                     |
| Current consumption                  |                                | 110 mA or less (excluding connected sensor amplifiers / input units / I/O extension units)  |                  |                  |                   |                     |
| Allowable passing current            |                                | Wire-saving connector 2 A (Note 3), supply connector 6 A (Note 4)   |                  |                  |                   |                     |
| Communication method                 |                                | CC-Link Ver.1.10  |                  |                  |                   |                     |
| Number of occupied station           |                                | Switchable 1 or 4 station   |                  |                  |                   |                     |
| Baud rate                            |                                | 10 Mbps   | 5 Mbps           | 2.5 Mbps         | 625 kbps          | 156 kbps            |
| Total extension length               |                                | 100 m 328.084 ft  | 150 m 492.126 ft | 200 m 656.168 ft | 600 m 1968.504 ft | 1,200 m 3937.008 ft |
| Communication cable                  |                                | Specified cable (twist pair cable with shield) (Note 5)   |                  |                  |                   |                     |
| Station No. setting                  |                                | 1 to 64 (0 and 65 or more: Error)   |                  |                  |                   |                     |
| Remote station type                  |                                | Remote device station   |                  |                  |                   |                     |
| Ambient temperature                  |                                | -10 to +55 °C +14 to +131 °F (If 4 to 7 units are connected in cascade: -10 to +50 °C +14 to +122 °F, if 8 to 16 units are connected in cascade: -10 to +45 °C +14 to +113 °F) (No dew condensation or icing allowed), Storage: -20 to +70 °C -4 to +158 °F |                  |                  |                   |                     |
| Ambient humidity                     |                                | 35 to 85 % RH, Storage: 35 to 85 % RH   |                  |                  |                   |                     |
| Material                             |                                | Enclosure: Heat-resistant ABS, Connector cap: Silicone rubber   |                  |                  |                   |                     |
| Weight                               |                                | Net weight: 60 g approx., Gross weight: 100 g approx.   |                  |                  |                   |                     |
| Accessory                            |                                | Connector cap: 2 pcs.   |                  |                  |                   |                     |

- Notes: 1) Where measurement conditions have not been specified precisely, the conditions used were an ambient temperature of +23 °C +73.4 °F.  
 2) Only the below models respond to data communication. **FX-501/502**, **FX-301/305**, **LS-403**, **DPS-401/402**  
 3) Be sure to check that total current consumption of sensor amplifiers connected in cascade does not exceed allowable passing current.  
 4) In case of supplying power to other devices, be sure to set the current less than allowable passing current.  
 5) Use the CC-Link-specified cable.

### 1-channel connector input extension unit

| Designation                  | 1-channel connector input extension unit |  |
|------------------------------|--|--|
| Item                         | Model No.                                | Analog communication unit  |
|                              |  | <b>SC-T1JA</b>   |
| Supply voltage               |  | 12 to 24 V DC $\pm 1\%$ Ripple P-P 10 % or less (By power supplied from the <b>SC-GU2-C</b> .)   |
| Current consumption (Note 2) |  | Max. 25 mA or less (when all indicators light up)  |
| Analog voltage input         |  | Input voltage range: 1 to 5 V DC<br>Input impedance: 200 kΩ approx.  |
| Communication data (Note 3)  |  | Analog ↔ Communication data<br>• Communication data: 0 to 4,000 digits (in the range of 1 to 5 V)<br>• Zero point: Within 0 digit $\pm 0.5$ % F.S.<br>• Span: Within 4,000 digits $\pm 0.5$ % F.S.<br>• Linearity: Within $\pm 0.5$ % F.S.   |
| Input                        |  | Connectable device: Output type of NPN open-collector transistor<br>Supply current for input device: 100 mA or less<br>Input impedance: 17 kΩ approx.<br>Operating voltage: 17 V or more at ON voltage (between input and +V at 24 V)<br>4 V or less at OFF voltage (between input and +V at 24 V) |
| Output                       |  | NPN open-collector transistor<br>• Max. sink current: 50 mA<br>• Applied voltage: 30 V DC or less<br>• Residual voltage: 1.5 V or less (at 50 mA sink current)   |
| Power indicator              |  | Green LED (lights up when the power is ON)   |
| Input indicator              |  | Green LED (lights up when NPN input is ON)   |
| Ambient temperature          |  | -10 to +55 °C +14 to +131 °F (If 4 to 7 units are connected in cascade: -10 to +50 °C +14 to +122 °F, if 8 to 16 units are connected in cascade: -10 to +45 °C +14 to +113 °F) (No dew condensation or icing allowed), Storage: -10 to +70 °C +14 to +158 °F                                       |
| Ambient humidity             |  | 35 to 85 % RH, Storage: 35 to 85 %   |
| Temperature characteristics  |  | Within $\pm 1$ % F.S. (at +25 °C +77 °F reference)   |
| Material                     |  | Enclosure: Heat-resistant ABS  |
| Weight                       |  | Net weight: 20 g approx., Gross weight: 40 g approx.   |
| Accessory                    |  | Connector (e-CON): 1 pc.   |

- Notes: 1) Where measurement conditions have not been specified precisely, the conditions used were an ambient temperature of +23 °C +73.4 °F.  
 2) The current consumption and input current of output device connected are not included.  
 3) The relationship between communication data and input voltage is as described in the right figure.

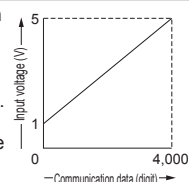

## SPECIFICATIONS

### End unit

| Designation         |                       | End unit   |
|---------------------|-----------------------|--|
| Item                | Model No.             | <b>SC-GU2-EU</b>   |
| Supply voltage      |                       | 12 to 24 V DC $\pm 10\%$ Ripple P-P 10 % or less (By power supplied from the <b>SC-GU2-C</b> ) |
| Current consumption |                       | 10 mA or less  |
| Signal channel No.  |                       | (Not occupy the signal channel No.)  |
| Power indicator     |                       | Green LED (lights up when the power is ON)   |
| Cable               | Type                  | 0.38 mm <sup>2</sup> single shielded cable [Heat resistant PVC (Black)]                        |
|                     | Sheath outer diameter | $\varnothing 1.46$ mm $\varnothing 0.057$ in   |
|                     | Length                | 30 to 180 mm <b>1.181 to 7.087 in</b> adjustable by cable length adjust button                 |
|                     | Tensile strength      | Main body side: 20 N (Note 2)  |
| Material            |                       | Enclosure: Heat-resistant ABS  |
| Weight              |                       | Net weight: 20 g approx., Gross weight: 40 g approx.   |

Notes: 1) Where measurement conditions have not been specified precisely, the conditions used were an ambient temperature of +23 °C **+73.4 °F**.

2) For length adjustment of cable with communication connector, pull out the cable slowly. To remove the cable with communication connector from **SC-GU2-C**, hold the connector and remove it.

### Connector input extension units / connector I/O extension units

| Designation                       |           | 1-channel connector input extension unit  | 8-channel connector input extension unit                 | 8-channel connector I/O mixed extension unit                      |
|-----------------------------------|-----------|---|--|---|
| Item                              | Model No. | <b>SC-T1J</b>   | <b>SC-T8J</b>  | <b>SC-TP8J</b>  |
| Supply voltage                    |           | 12 to 24 V DC $\pm 10\%$ (By power supplied from the <b>SC-GU2-C</b> )  |  | 5 to 24 V DC $\pm 10\%$ (Note 2)                                  |
| Current consumption (Note 3)      |           | 20 mA or less (when all indicators light up)  | 60 mA or less (when all indicators light up)             | 7 mA or less  |
| Signal channel No.                |           | 1 input   | 8 inputs (Note 4)  | 8 inputs / outputs (Note 5)                                       |
| Connectable device                |           | NPN open-collector, or DC 2-wire output type sensor, or switch etc.   | NPN open-collector output sensor or switch etc. (Note 6) | commercially available I/O device including DC 2-wire type sensor |
| Supply current for units (Note 7) |           | 100 mA or less  | 800 mA or less (At a total of 8 channels)                |   |
| Power indicator                   |           | Green LED (Lights up when the power is ON)  |  |   |
| Input indicator                   |           | Green LED [ <b>SC-T1J</b> : 1 No., <b>SC-T8J</b> : 8 Nos.] (Lights up when each channel input is ON)                    |  |   |
| Ambient temperature               |           | -10 to +45 °C <b>+14 to +113 °F</b> (No dew condensation or icing allowed), Storage: -20 to +70 °C <b>-4 to +158 °F</b> |  |   |
| Ambient humidity                  |           | 35 to 85 % RH, Storage: 35 to 85 % RH   |  |   |
| Material                          |           | Enclosure: Heat-resistant ABS   |  |   |
| Net weight                        |           | 10 g approx.  | 40 g approx.   |   |
| Accessories                       |           | <b>SL-CP1</b> (Snap male connector): 1 pc.  | Index seal : 1 pc.                                       |   |

Notes: 1) Where measurement conditions have not been specified precisely, the conditions used were an ambient temperature of +20 °C **+68 °F**.

- 2) It depends on the power supply from **SC-MIL**.
- 3) The current consumption and input current of the input unit connected are not included.
- 4) The signal for 8 channels is occupied regardless of number of input units connected.
- 5) The signal for 8 channels is occupied regardless of number of I/O units connected.
- 6) DC 2-wire type sensor and switch etc. cannot be connected (**SC-T8J** only).
- 7) Set the maximum current passing through input / output line to 50 mA or less.

### Plug-in Sensor units (MIL connectors)

| Type                               |           | Separate unit   | Main unit  |
|------------------------------------|-----------|---|--|
| Item                               | Model No. | <b>SC-MIL-S</b>   | <b>SC-MIL</b>  |
| Supply voltage                     |           | By power supplied from the <b>SC-GU2-C</b>  | 12 to 24 V DC $\pm 10\%$ (Note 2)<br>By power supplied from the <b>SC-GU2-C</b>                              |
| Allowable through current (Note 3) |           | 1 A or less<br>( Same as maximum permissible current consumption of all units connected to <b>SC-MIL-S</b> . )  | 2 A or less<br>( Same as maximum permissible current consumption of all units connected to <b>SC-MIL</b> . ) |
| Signal channel No.                 |           | Connectable up to 16 channels<br>( The signal from up to 16th point (counting from unit adjacent to <b>SC-MIL</b> ) of all units connected to <b>SC-MIL</b> is transferred. )<br>However, the signal thereafter is not transferred. Note that <b>SC-MIL</b> and <b>SC-MIL-S</b> do not occupy any signal point. |  |
| Max. distance between units        |           | 10 m <b>32.808 ft</b> or less (the distance between <b>SC-MIL</b> and PLC and that between <b>SC-MIL</b> and <b>SC-MIL-S</b> put together)  |  |
| Ambient temperature                |           | -10 to +45 °C <b>+14 to +113 °F</b> (No dew condensation or icing allowed), Storage: -20 to +70 °C <b>-4 to +158 °F</b>   |  |
| Ambient humidity                   |           | 35 to 85 % RH, Storage: 35 to 85 % RH   |  |
| Material                           |           | Enclosure: Heat-resistant ABS   |  |
| Weight                             |           | Net weight: 20 g approx.  | Net weight: 25 g approx.   |
| Accessory                          |           | Connector protection seal: 1 pc.  |  |

Notes: 1) Where measurement conditions have not been specified precisely, the conditions used were an ambient temperature of +20 °C **+68 °F**.

- 2) The plug-in sensor main unit **SC-MIL** incorporates a cable lead-out connector in addition to the MIL connector, which allows to receive the supply voltage from the separate power supply.
- 3) When either the power supply device's allowable amount of current or the connecting cable's allowable amount of current is smaller than the allowable current passage value, match it with the smallest specification.

**PRECAUTIONS FOR PROPER USE**



- Never use this product in a device for personnel protection.
- In case of using sensing devices for personnel protection, use products which meet laws and standards, such as OSHA, ANSI or IEC etc., for personnel protection applicable in each region or country.

**DIMENSIONS (Unit: mm in)**

The CAD data in the dimensions can be downloaded from our website

**SC-GU2-C** Communication unit for CC-Link

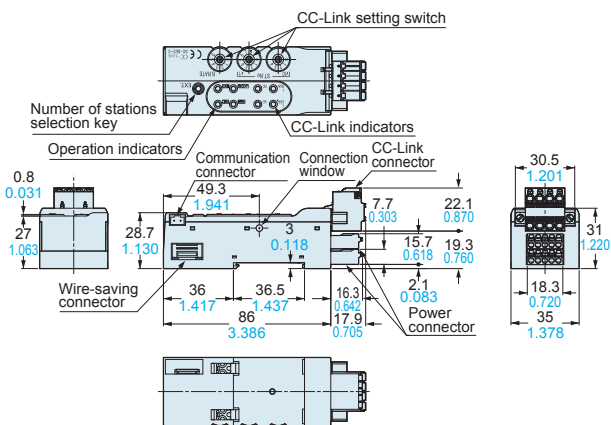

**SC-GU2-EU** End unit

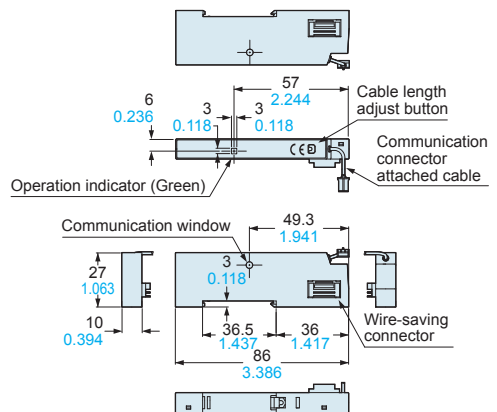

**SC-T1JA** 1-channel connector input extension unit

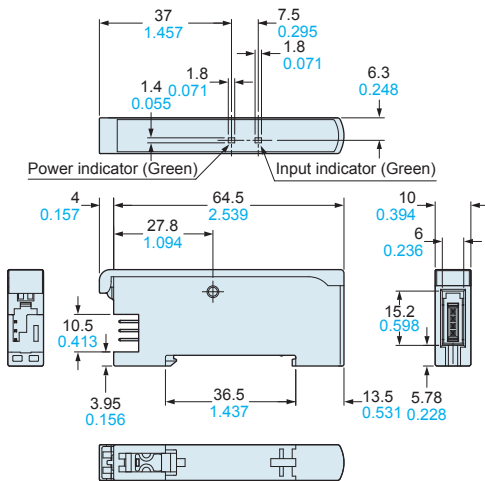

**CN-70** Non-line connector (Optional)

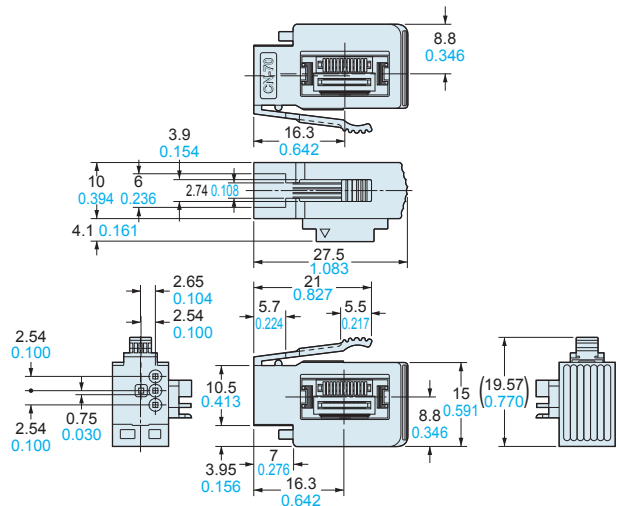

**MS-DIN-E** End plates (Optional)

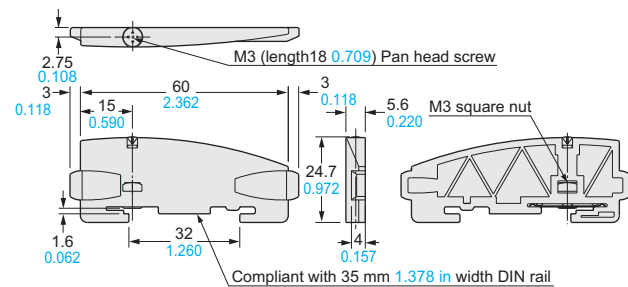

Material: Polycarbonate

## Disclaimer

The applications described in the catalog are all intended for examples only. The purchase of our products described in the catalog shall not be regarded as granting of a license to use our products in the described applications. We do NOT warrant that we have obtained some intellectual properties, such as patent rights, with respect to such applications, or that the described applications may not infringe any intellectual property rights, such as patent rights, of a third party.

**Panasonic**  
INDUSTRY

**Panasonic Industry Co., Ltd.**

Industrial Device Business Division

7-1-1, Morofuku, Daito-shi, Osaka 574-0044, Japan

[industrial.panasonic.com/ac/e/](http://industrial.panasonic.com/ac/e/)