

**!** Partly to Be Discontinued  
Last time buy: September 30, 2024

# Automotive Relays

# CJ RELAYS

Product Catalog

**IN Your  
Future**

# Compact Slim Twin and Single Type Automotive Relay

◁Protective construction▷  
Standard type: Sealed  
Pin in Paste compliant type: Flux tight

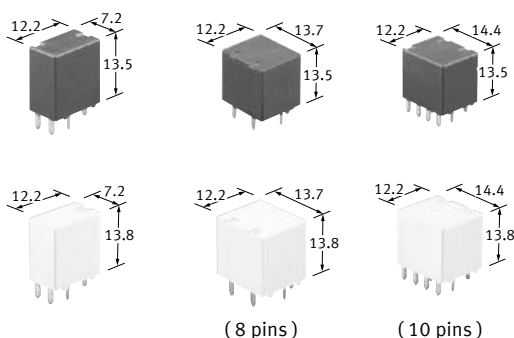

(Unit: mm)

## FEATURES

- It is extremely compact at approx. 2/3 the size of previous CT relay.
- Compact and high-capacity 25 A load switching
- Pin in Paste compliant model added

## TYPICAL APPLICATIONS

- Powered windows, Automatic door locks, Powered mirrors, Powered sunroofs, Powered seats, Lift gates and Smart J/B related products, etc.

## ORDERING INFORMATION (PART NO.)

### ACJ

- Contact arrangement  
1: 1 Form C  
2: 1 Form C×2 (8 pins)  
5: 1 Form C×2 (10 pins)
- Operate voltage  
1: Max. 6.5 V DC  
2: Max. 7.2 V DC
- Rated coil voltage, DC  
12: 12 V
- Mounting type  
Nil: Standard type  
P: Pin in Paste compliant type

## TYPES

Contact arrangement	Rated coil voltage	Operate voltage (at 20°C) (initial)	Part No.		Packing	
			Standard type	Pin in Paste compliant type	Carton (1-tube)	Case
1 Form C	12 V DC	Max. 6.5 V DC	ACJ1112	ACJ1112P	70 pcs.	2,800 pcs.
		Max. 7.2 V DC	ACJ1212	ACJ1212P		
1 Form C x 2 (8 pins)		Max. 6.5 V DC	ACJ2112	ACJ2112P	40 pcs.	1,000 pcs.
		Max. 7.2 V DC	ACJ2212	ACJ2212P		
1 Form C x 2 (10 pins)		Max. 6.5 V DC	ACJ5112	ACJ5112P	35 pcs.	1,400 pcs.
		Max. 7.2 V DC	ACJ5212	ACJ5212P		

## RATING

### Coil data

Rated coil voltage	Operate voltage (at 20°C) (initial)	Release voltage (at 20°C) (initial)	Rated operating current [±10%] (at 20°C)	Coil resistance [±10%] (at 20°C)	Rated operating power (at 20°C)	Usable voltage range*
12 V DC	Max. 7.2 V DC	Min. 1.0 V DC	53.3 mA	225 Ω	640 mW	10 to 16 V DC
	Max. 6.5 V DC	Min. 0.8 V DC	66.7 mA	180 Ω	800 mW	9 to 16 V DC

Note: \*Other usable voltage range types are also available. Please inquire our sales representative for details.

# Automotive Relays CJ RELAYS

## Specifications

Item	Specifications	
Contact data	Contact arrangement	1 Form C, 1 Form C x 2
	Contact resistance (initial)	Max. 50 mΩ (N.O. side: typ. 7 mΩ, N.C. side: typ. 10 mΩ) (By voltage drop 1 A 6 V DC)
	Contact material	Ag alloy
	Rated switching capacity (resistive)	N.O. side: 20 A 14 V DC, N.C. side: 10 A 14 V DC
	Max. carrying current*1	N.O. side: 20 A/1 hour, 30 A/2 min (Coil applied voltage 14 V DC at 20°C)
	Min. switching load (resistive)*2	1 A 14 V DC (at 20°C)
Insulated resistance (initial)		Min. 100 MΩ (at 500 V DC, Measurement at same location as "Dielectric strength" section.)
Dielectric strength (initial)	Between open contacts	500 Vrms for 1 min (Detection current: 10 mA)
	Between contacts and coil	500 Vrms for 1 min (Detection current: 10 mA)
Time characteristics (initial)	Operate time (at rated voltage)	Max. 10 ms (at 20°C, without contact bounce time)
	Release time (at rated voltage)	Max. 10 ms (at 20°C, without contact bounce time) (without diode)
Shock resistance	Functional	Min. 100 m/s <sup>2</sup> (Half-wave pulse of sine wave: 11 ms, detection time: 10 μs)
	Destructive	Min. 1,000 m/s <sup>2</sup> (Half-wave pulse of sine wave: 6 ms)
Vibration resistance	Functional	10 to 100 Hz, Min. 44.1 m/s <sup>2</sup> (detection time: 10 μs)
	Destructive	10 to 500 Hz, Min. 44.1 m/s <sup>2</sup> Time of vibration for each direction; X, Y direction: 2 hours, Z direction: 4 hours
Expected life	Mechanical	Min. 10 <sup>7</sup> (at 120 times/min)
	Electrical	[Standard type] <Resistive load> Min. 10 <sup>5</sup> (at rated switching capacity, operating frequency: 1 s ON, 9 s OFF) <Motor load> N.O. side; Min. 2 x 10 <sup>5</sup> at 25 A (inrush), 5 A (steady), 14 V DC; Min. 10 <sup>5</sup> : at 25 A 14 V DC (motor lock) N.C. side; Min. 2 x 10 <sup>5</sup> at 20 A 14 V DC (break) (operating frequency: 0.5 s ON, 9.5 s OFF) [Pin in Paste compliant type] <Resistive load> Min. 10 <sup>5</sup> (at rated switching capacity, operating frequency: 1 s ON, 9 s OFF) <Motor load> N.O. side; Min. 10 <sup>5</sup> at 25 A (inrush), 5 A (steady), 14 V DC; Min. 5 x 10 <sup>5</sup> : at 25 A 14 V DC (motor lock) N.C. side; Min. 10 <sup>5</sup> at 20 A 14 V DC (break) (operating frequency: 0.5 s ON, 9.5 s OFF)
Conditions	Conditions for usage, transport and storage*3	Ambient temperature: -40 to +85°C, Humidity: 5 to 85% RH (Avoid icing and condensation)
Weight		1 Form C type: approx. 3.5 g, Twin type: approx. 6.5 g

Notes: \*1. Depends on connection conditions. Also, this does not guarantee repeated switching. We recommend that you confirm operation under actual conditions.  
 \*2. This value can change due to the switching frequency, environmental conditions, and desired reliability level, therefore it is recommended to check this with the actual load.  
 \*3. The upper operation ambient temperature limit is the maximum temperature that can satisfy the coil temperature rise value. For details, please refer to the "Automotive Relay Users Guide".  
 Please inquire our sales representative if you will be using the relay in a high temperature atmosphere (110°C).  
 ★ If the relay is used continuously for long periods of time with coils on both sides in an energized condition, breakdown might occur due to abnormal heating depending on the carrying condition. Therefore, please inquire our sales representative when using with a circuit that causes an energized condition on both sides simultaneously.

## REFERENCE DATA

### 1-1. Coil temperature rise (at room temperature)

Sample: ACJ1212, 3 pcs  
 Measured portion: Inside the coil  
 Carrying current: 10 A, 15 A, 20 A  
 Ambient temperature: 25°C

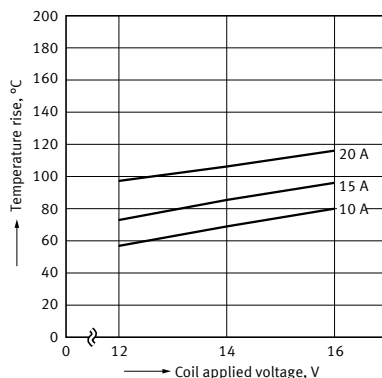

### 1-2. Coil temperature rise (at 85°C)

Sample: ACJ1212, 3 pcs  
 Measured portion: Inside the coil  
 Carrying current: 10 A, 15 A, 20 A  
 Ambient temperature: 85°C

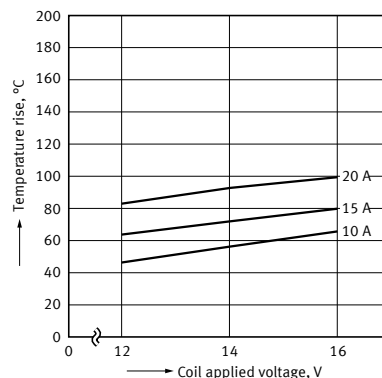

### 1-3. Coil temperature rise (at room temperature)

Sample: ACJ2212, 3 pcs  
 Measured portion: Inside the coil  
 Carrying current: 10 A, 15 A, 20 A  
 Ambient temperature: 25°C

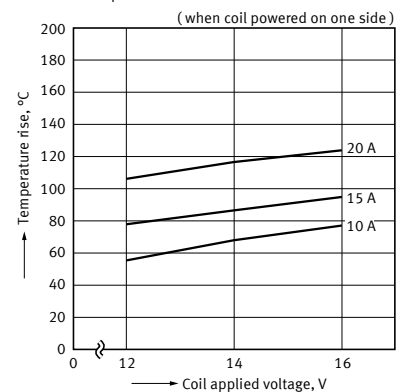

1-4. Coil temperature rise  
(at 85°C)

Sample: ACJ2212, 3 pcs  
Measured portion: Inside the coil  
Carrying current: 10 A, 15 A, 20 A  
Ambient temperature: 85°C

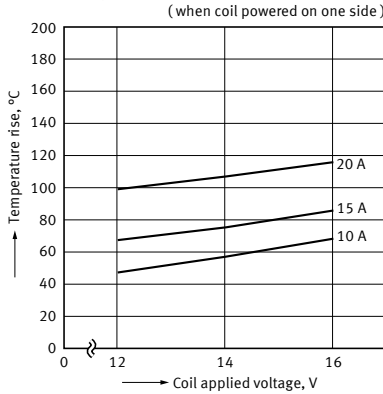

1-5. Coil temperature rise  
(at room temperature)

Sample: ACJ5212, 3 pcs  
Measured portion: Inside the coil  
Carrying current: 10 A, 15 A, 20 A  
Ambient temperature: 25°C

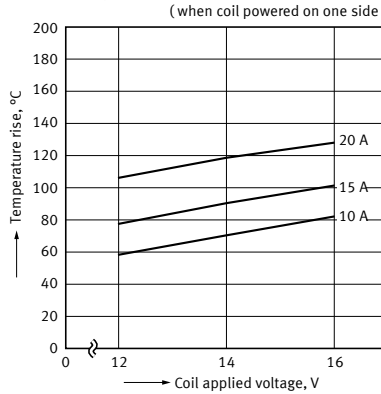

1-6. Coil temperature rise  
(at 85°C)

Sample: ACJ5212, 3 pcs  
Measured portion: Inside the coil  
Carrying current: 10 A, 15 A, 20 A  
Ambient temperature: 85°C

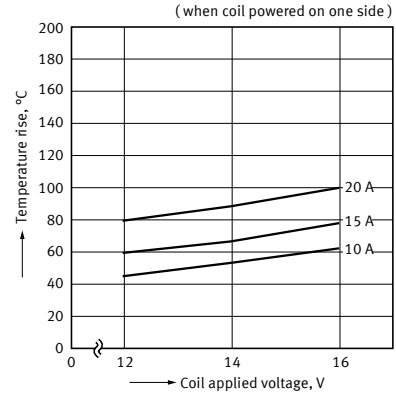

2-1. Ambient temperature and usable voltage range

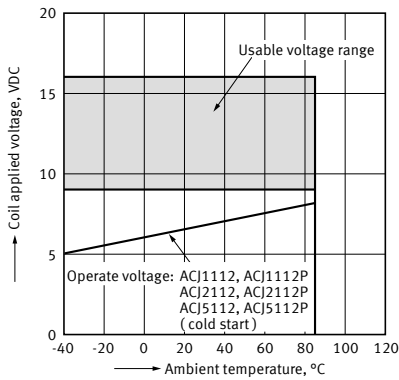

2-2. Ambient temperature and usable voltage range

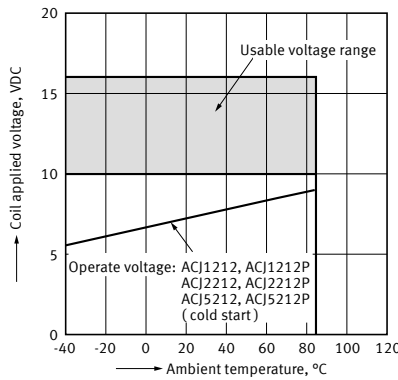

3-1. Distribution of operate and release voltage

Sample: ACJ2112, 50 pcs.  
Ambient temperature: Room temperature

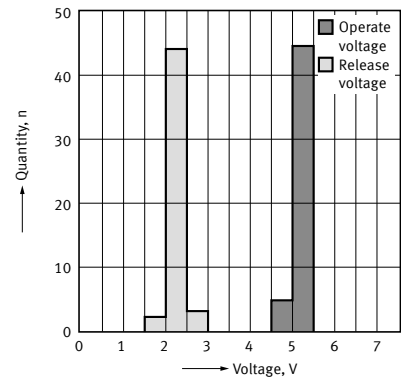

3-2. Distribution of operate and release voltage

Sample: ACJ2212, 50 pcs.  
Ambient temperature: Room temperature

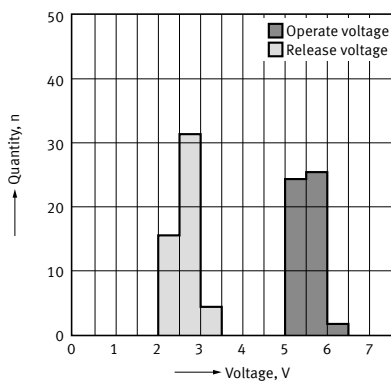

4-1. Distribution of operate and release time 4-2. Distribution of operate and release time

Sample: ACJ1212, 50 pcs.  
Ambient temperature: Room temperature

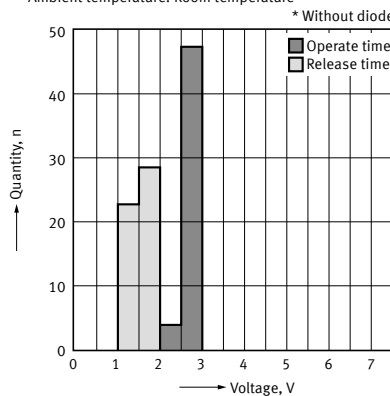

Sample: ACJ2212, 50 pcs.  
Ambient temperature: Room temperature

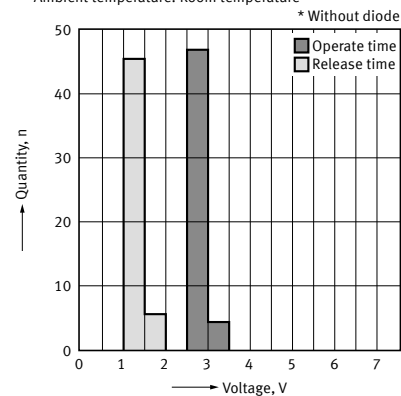

## 5-1. Electrical life test (Motor free)

Sample: ACJ2212, 3 pcs  
 Load: Inrush current: 25 A, Steady current: 5 A,  
 Power window motor actual load (free condition)  
 Tested voltage: 14 V DC  
 Operating frequency: ON 0.5 s, OFF 9.5 s  
 Switching cycle:  $2 \times 10^5$   
 Ambient temperature: Room temperature  
 Circuit:

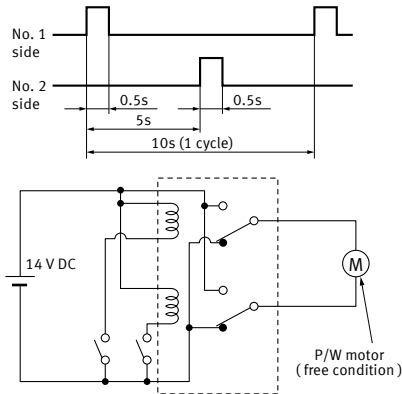

Change of operate and release voltage

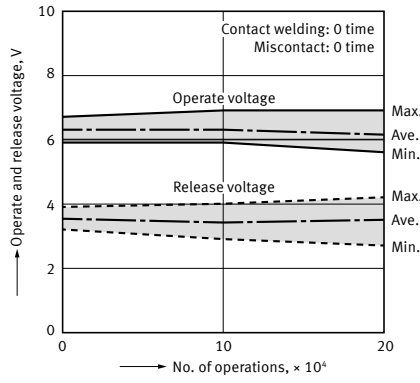

Change of contact resistance

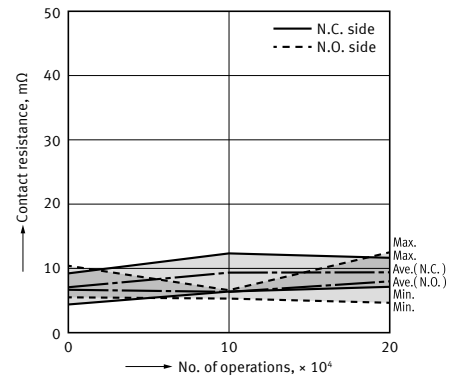

Load current waveform  
 Load; Inrush current: 25 A, Steady current: 6 A,  
 Brake current: 13 A

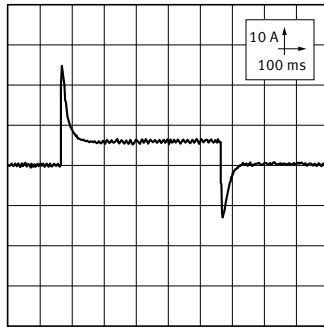

## 5-2. Electrical life test (Motor lock)

Sample: ACJ2212, 3 pcs  
 Load: Steady current: 25 A, Power window motor  
 actual load (lock condition)  
 Tested voltage: 14 V DC  
 Operating frequency: ON 0.5 s, OFF 9.5 s  
 Switching cycle:  $10^5$   
 Ambient temperature: Room temperature  
 Circuit:

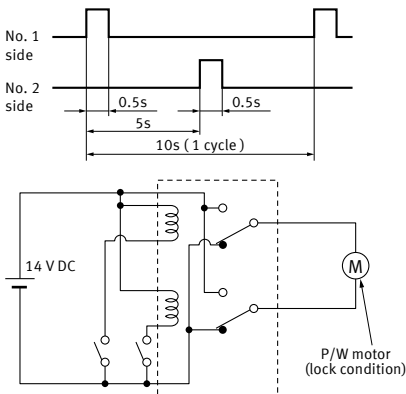

Change of operate and release voltage

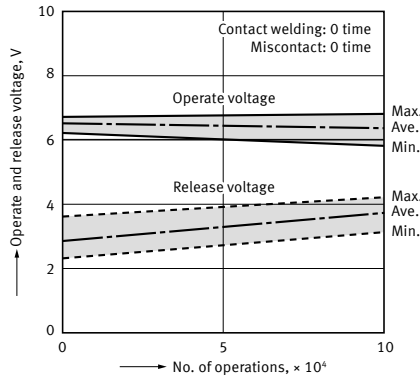

Change of contact resistance

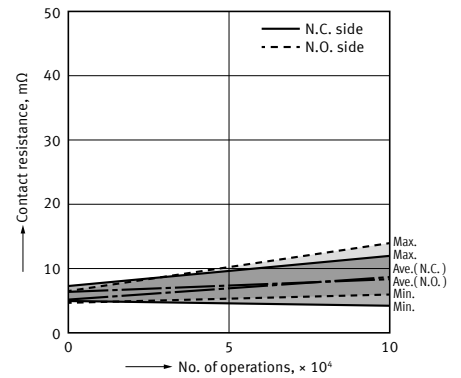

Load current waveform  
 Current value: 25 A

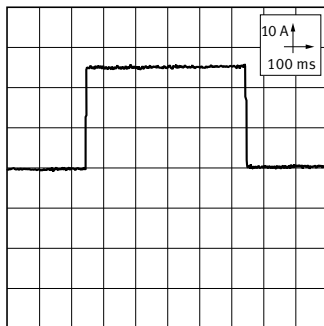

**DIMENSIONS**

**CAD** The CAD data of the products with a "CAD" mark can be downloaded from our Website.

Unit: mm

**■ Twin type (8 pins)**

Standard type

**CAD**



**External dimensions**

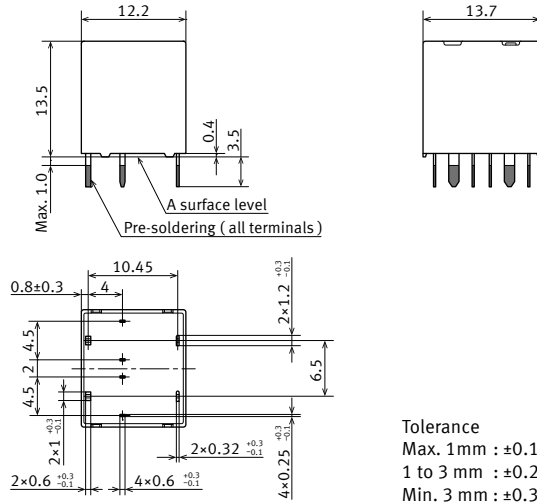

Tolerance  
Max. 1mm : ±0.1  
1 to 3 mm : ±0.2  
Min. 3 mm : ±0.3

\* Dimensions (thickness and width) of terminal is measured before pre-soldering. Intervals between terminals is measured at A surface level.

**PC board pattern (BOTTOM VIEW)**

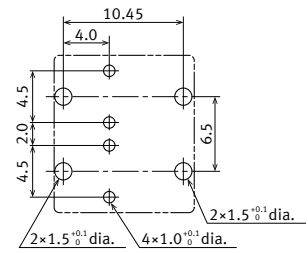

Tolerance: ± 0.1

**Schematic (BOTTOM VIEW)**

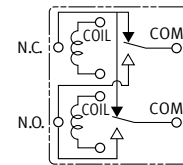

**■ Twin type (8 pins)**

Pin in Paste compliant type

**CAD**



**External dimensions**

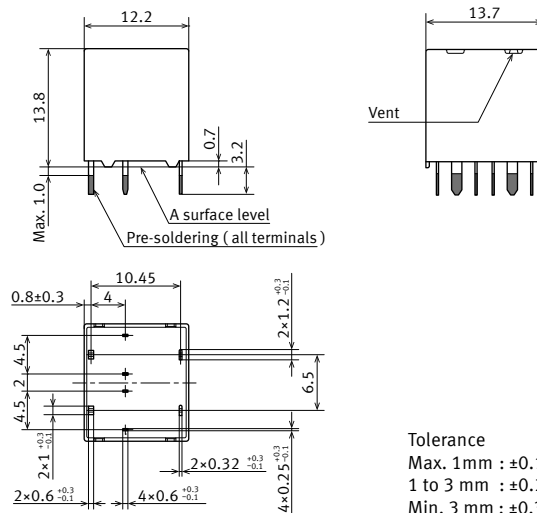

Tolerance  
Max. 1mm : ±0.1  
1 to 3 mm : ±0.2  
Min. 3 mm : ±0.3

\* Dimensions (thickness and width) of terminal is measured before pre-soldering. Intervals between terminals is measured at A surface level.

**PC board pattern (BOTTOM VIEW)**

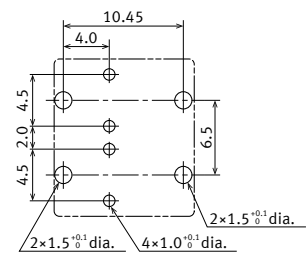

Tolerance: ± 0.1

**Schematic (BOTTOM VIEW)**

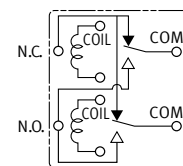

# Automotive Relays CJ RELAYS

## ■ Twin type (10 pins)

Standard type

**CAD**



External dimensions

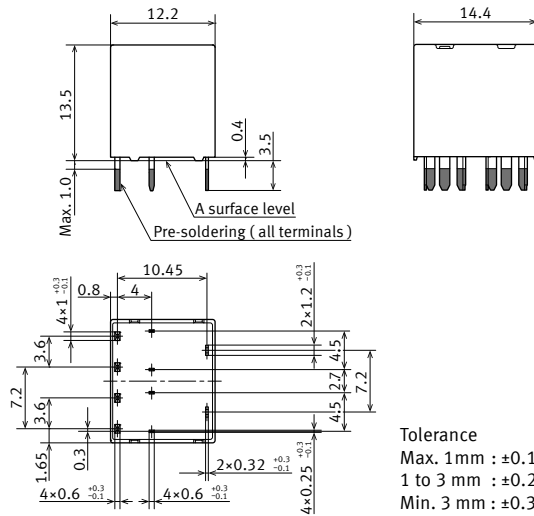

Tolerance  
Max. 1 mm : ±0.1  
1 to 3 mm : ±0.2  
Min. 3 mm : ±0.3

\* Dimensions (thickness and width) of terminal is measured before pre-soldering.  
Intervals between terminals is measured at A surface level.

PC board pattern (BOTTOM VIEW)

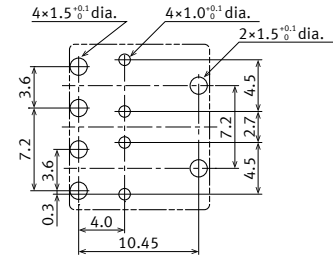

Tolerance: ± 0.1

Schematic (BOTTOM VIEW)

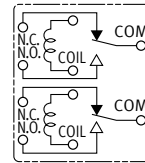

## ■ Twin type (10 pins)

Pin in Paste compliant type

**CAD**



External dimensions

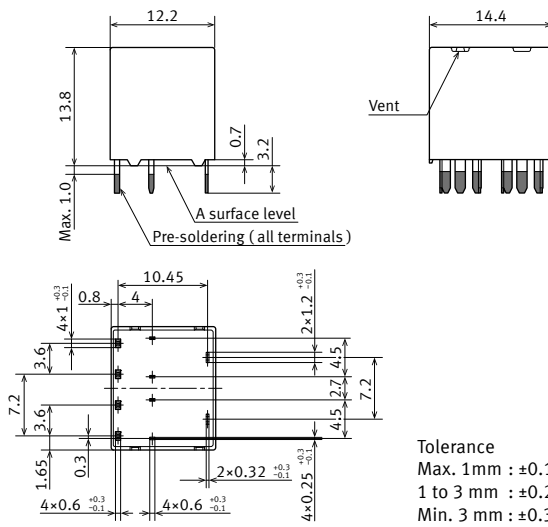

Tolerance  
Max. 1 mm : ±0.1  
1 to 3 mm : ±0.2  
Min. 3 mm : ±0.3

\* Dimensions (thickness and width) of terminal is measured before pre-soldering.  
Intervals between terminals is measured at A surface level.

PC board pattern (BOTTOM VIEW)

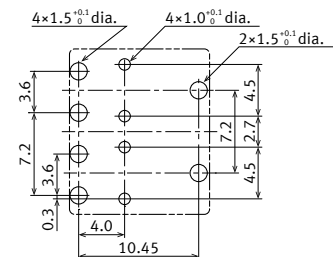

Tolerance: ± 0.1

Schematic (BOTTOM VIEW)

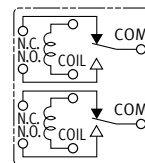

**Slim 1 Form C type**

Standard type

**CAD**



External dimensions

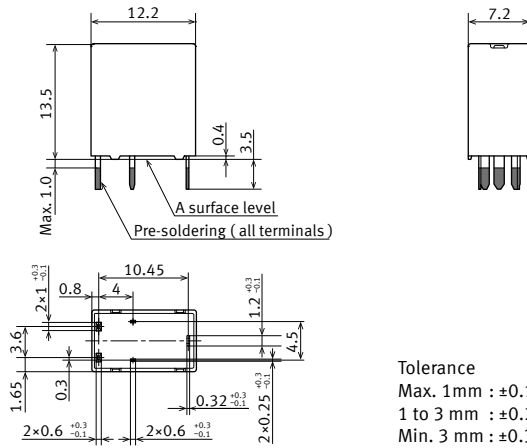

PC board pattern  
(BOTTOM VIEW)

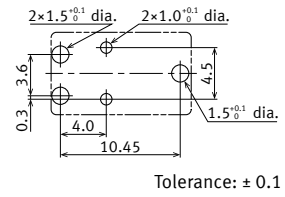

Tolerance: ± 0.1

Schematic  
(BOTTOM VIEW)

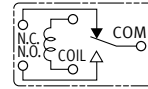

Tolerance  
Max. 1mm : ±0.1  
1 to 3 mm : ±0.2  
Min. 3 mm : ±0.3

\* Dimensions (thickness and width) of terminal is measured before pre-soldering.  
Intervals between terminals is measured at A surface level.

**Slim 1 Form C type**

Pin in Paste compliant type

**CAD**



External dimensions

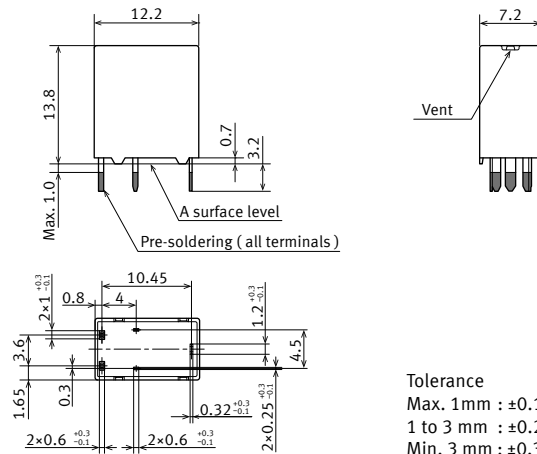

PC board pattern  
(BOTTOM VIEW)

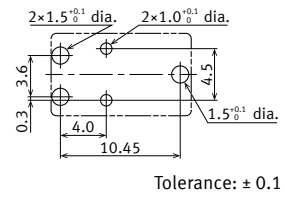

Tolerance: ± 0.1

Schematic  
(BOTTOM VIEW)

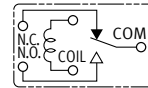

Tolerance  
Max. 1mm : ±0.1  
1 to 3 mm : ±0.2  
Min. 3 mm : ±0.3

\* Dimensions (thickness and width) of terminal is measured before pre-soldering.  
Intervals between terminals is measured at A surface level.



## GUIDELINES FOR USAGE

■ For general cautions for use, please refer to the "Automotive Relay Users Guide".

### ■ Precautions when using CJ relays

- Mounting and cleaning conditions for Pin in Paste compliant type

When soldering this relay, the following conditions should be observed.

[I.R.S method (recommended)]

(Recommended condition Number of reflow operation: 1 time)

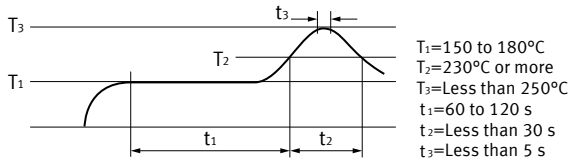

#### 1) Cautions for mounting

- (1) The temperature profile shows the temperature at the soldering portion on the PC board surface.
- (2) Depending on the mounting density condition, reflow heating method and PC board type (metal etc.) the relay's exterior and interior temperature may become extremely high. Therefore, please confirm well under the actual use condition before use.

#### 2) The other cautions of reflow soldering

- (1) When soldering condition is out of recommendation, the relay performance may be adversely affected. If soldering conditions are out of our recommendation, please inquire our sales representative before operation.

- (2) Please check the effect at the actual soldering because heat stress to relay is changed by PC board type and manufacturing process condition.
- (3) Solder creepage, wettability or soldering strength will be affected by the mounting condition or soldering material. Please check the actual production condition in detail.
- (4) Do not wash the relay as failures may occur.
- (5) This product is not plastic sealed type. Please perform coating with sufficient attention to avoid infiltration of the solvent to the inside. Also, please pay careful attention to use and store them with no contamination of foreign material.

Please refer to "**the latest product specifications**" when designing your product.

•Requests to customers:

<https://industrial.panasonic.com/ac/e/salespolicies/>

---

**Panasonic**  
INDUSTRY

**Panasonic Industry Co., Ltd.**

Electromechanical Control Business Division  
■1006, Oaza Kadoma, Kadoma-shi, Osaka 571-8506, Japan  
[industrial.panasonic.com/ac/e/](http://industrial.panasonic.com/ac/e/)