

PAN1783

Bluetooth® Low Energy Module

Product Specification

Rev. 0.1



Overview

The PAN1783 is a Bluetooth 5.3 Low Energy (LE) module based on the Nordic nRF5340 single chip controller.

Features

- Surface mount type dimensions: 15.6 mm x 8.7 mm x 2.2 mm
- Same form factor as PAN1780 with the same pitch but one more pin
- Nordic nRF5340 featuring two Cortex®-M33 processors: one as an application processor (with 128 MHz or 64 MHz operation, 512 kB RAM, built-in 1 MB flash memory), and the other one as a network processor (with 64 MHz operation, 64 kB RAM, 256 kB flash)
- Bluetooth 5.3 LE including LE 2M and LE Coded PHY
- Supports 802.15.4 ZigBee® and Thread
- Includes ARM TrustZone® CryptoCell™ 312, SPU, KMU, ACL
- Security features: Trusted execution, root-of-trust, secure key storage, 128-bit AES
- Up to 48x General Purpose I/Os (GPIO), which are shared by up to 5x SPI, 4x I²C, 4x UART, 4x PWM, 8x ADC, NFC-A, QSPI, nRESET
- USB 2.0 full-speed device interface
- APPROTECT available

Bluetooth

- LE Audio: audio streaming over Bluetooth LE, multi-stream synchronized audio and Audio Sharing
- Long range
- High-through-put 2 Mbps and Advertising Extensions features
- Bluetooth mesh

Characteristics

- Typical sensitivity: -98 dBm (at 1 Mb/s) and -104 dBm (at 125 kb/s in LE-mode – long range)
- Programmable from: 3 dBm to -20 dBm in 1 dB steps
- Typical System current consumption: 0.9 μA (in System OFF), 1.3 μA (in System ON), 1.5 μA (in System ON with network core RTC running)
- Typical Radio current consumption: 5.1 mA (at 3 dBm Tx power), 3.4 mA (at 0 dBm Tx power), 2.7 mA (in Rx at 1 Mbps), 3.1 mA (in Rx at 2 Mbps)
- On-module DC-DC and LDO regulators with automated low current modes
- Voltage range: 1.7 V to 5.5 V
- Temperature range: -40 °C to 85 °C

Block Diagram

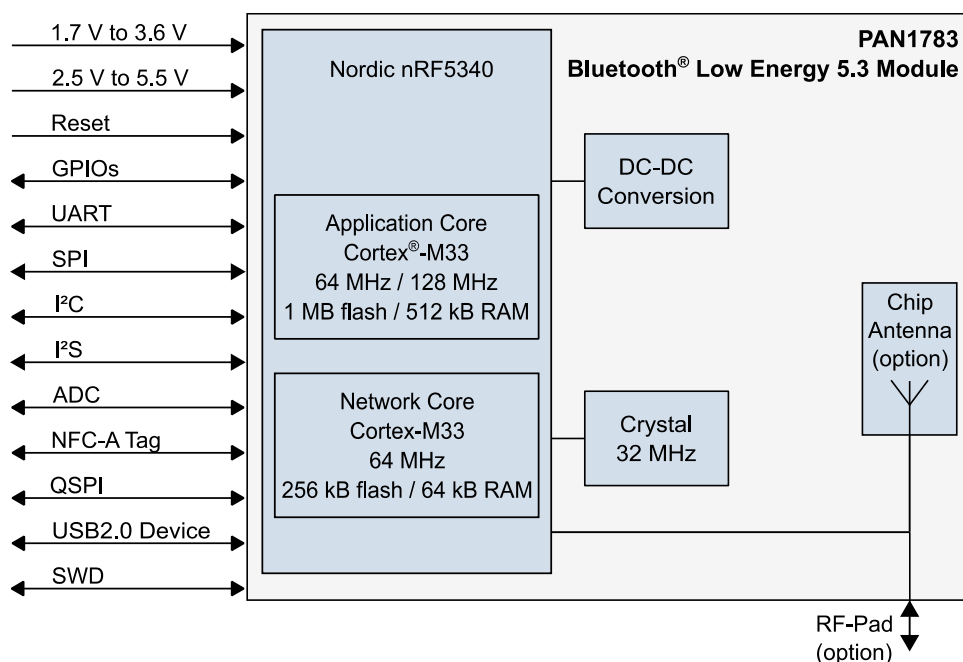

By purchase of any of the products described in this document the customer accepts the document's validity and declares their agreement and understanding of its contents and recommendations. Panasonic Industrial Devices Europe GmbH (Panasonic) reserves the right to make changes as required at any time without notification. Please consult the most recently issued Product Specification before initiating or completing a design.

© Panasonic Industrial Devices Europe GmbH 2023.

This specification sheet is copyrighted. Reproduction of this document is permissible only if reproduction is without alteration and is accompanied by all associated warranties, conditions, limitations, and notices. Do not disclose it to a third party.

All rights reserved.

This Product Specification does not lodge the claim to be complete and free of mistakes.

If this document is marked as preliminary, please be aware that its final content is not yet concluded and the use of it is at your own risk.

Document Acceptance

By signing the Product Specification, you acknowledge that you are a legal representative for your company and that you understand and accept the validity of the contents herein.

If the signed version of the Product Specification has not been returned to Panasonic within 30 days after receipt of the product, the specification or approval sheet shall be deemed to be accepted by you.

Engineering Samples (ES)

If Engineering Samples are delivered to the customer, these samples have the status "Engineering Samples". This means that the design of this product is not yet concluded. Engineering Samples may be partially or fully functional, and they may differ from the published Product Specification.

Engineering Samples are not qualified and they are not to be used for reliability testing or series production.

Disclaimer

The customer acknowledges that samples may deviate from the Product Specification and may bear defects due to their status of development and the lack of qualification mentioned above.

Panasonic rejects any liability or product warranty for Engineering Samples. In particular, Panasonic disclaims liability for damages caused by:

- The use of the Engineering Sample other than for evaluation purposes, particularly the installation or integration in another product to be sold by the customer,
- Deviation or lapse in function of the Engineering Sample,
- Improper use of the Engineering Sample.

Panasonic Industrial Devices Europe GmbH disclaims any liability for consequential and incidental damages. In case of any queries regarding the Engineering Samples, please contact your local sales partner or the related product manager.

Information on Software

The PAN1783 module does not contain any software ex works, i.e. software is provided by 3rd party suppliers only. The essential software resources can be found on the partner website of Nordic Semiconductor <https://www.nordicsemi.com/>.

PIDEU provides a factory software programming service for your customized firmware; for further information please reach out to your local sales contact this regarding ⇒ [7.2.1 Contact Us](#).

Table of Contents

1	About This Document	5
1.1	Purpose and Audience	5
1.2	Revision History.....	5
1.3	Use of Symbols	5
1.4	Related Documents	5
2	Overview	6
2.1	Block Diagram	7
2.2	Pin Configuration	8
2.3	Peripherals	11
2.4	Bluetooth Features	11
3	Detailed Description	12
3.1	Dimensions.....	12
3.2	Footprint	13
3.3	Packaging.....	14
3.4	Case Marking	17
4	Specification and Integration Recommendations	18
4.1	Default Test Conditions	18
4.2	Absolute Maximum Ratings.....	18
4.3	Recommended Operating Conditions.....	19
4.4	Current Consumption.....	19
4.5	Bluetooth	20
4.6	Access Port Protection APPROTECT.....	20
4.7	Antenna Placement Recommendation	21
4.8	Reliability Tests	23
4.9	Recommended Soldering Profile	24
5	Cautions	25
5.1	Design Notes	25
5.2	Installation Notes	25
5.3	Usage Condition Notes.....	26
5.4	Storage Notes.....	26
5.5	Safety Cautions	26
5.6	Other Cautions	27
5.7	Restricted Use	28
6	Regulatory and Certification Information	29
6.1	For Bluetooth Low Energy	29
6.2	For IEEE 802.15.4	30
6.3	RoHS and REACH Declaration	30
7	Appendix	31
7.1	Ordering Information.....	31
7.2	Contact Details	32

1 About This Document

1.1 Purpose and Audience



This Product Specification provides details on the functional, operational, and electrical characteristics of the Panasonic PAN1783 module. It is intended for hardware design, application, and Original Equipment Manufacturers (OEM) engineers.

The product is referred to as “PAN1783” and “module” within this document.

1.2 Revision History

Revision	Date	Modifications/Remarks
0.1	2023-04-06	First preliminary version

1.3 Use of Symbols

Symbol	Description
	<p>Note</p> <p>Indicates important information for the proper use of the product. Non-observance can lead to errors.</p>
	<p>Attention</p> <p>Indicates important notes that, if not observed, can put the product's functionality at risk.</p>
⇒ [chapter number] [chapter title]	<p>Cross reference</p> <p>Indicates cross references within the document.</p> <p>Example:</p> <p>Description of the symbols used in this document ⇒ 1.3 Use of Symbols.</p>

1.4 Related Documents

For related documents please refer to the Panasonic website ⇒ [7.2.2 Product Information](#).

2 Overview

The PAN1783 is a Bluetooth 5.3 LE module based on the Nordic nRF5340 single chip controller. It is available with an on-board chip antenna and with a RF-bottom pad.

The Bluetooth 5.3 features isochronous channels and LE audio. It supports high throughput of 2 Mbps, advertising extensions, and long range. The all-in-one SoC including a superset of the most prominent nRF52 Series features combined with more performance and memory, while minimizing current consumption.

An output power of up to 3 dBm and the improved sensitivity of the nRF5340 in combination with the LE coded PHY make the module very attractive for advanced computer peripherals and I/O devices, advanced wearables, and wireless audio devices.

In addition, the ultra-low current consumption of the PAN1783 makes the module an ideal choice for battery powered devices.

With two Cortex-M33 processors, one as an application processor (with 128 MHz or 64 MHz operation, 512 kB RAM, built-in 1 MB flash memory) and the other one as a network processor (with 64 MHz operation, 64 kB RAM, 256 kB flash), the PAN1783 can easily be used in standalone mode, thereby eliminating the need for an external processor, saving complexity, space, and cost.

The rich set of security features from the ARM TrustZone CryptoCell 312 security subsystem provide the necessary means for secure device operation in the IoT space.

The PAN1783 supports angle of arrival (AoA) and angle of departure (AoD) direction finding using Bluetooth. Additionally, the PAN1783 also supports Type 2 Near Field Communication (NFC-A) for use in simplified pairing and payment solutions (external antenna required).

For related documents please refer to [⇒ 7.2.2 Product Information](#).

For further information on the variants and versions please refer to [⇒ 7.1 Ordering Information](#).

2.1 Block Diagram

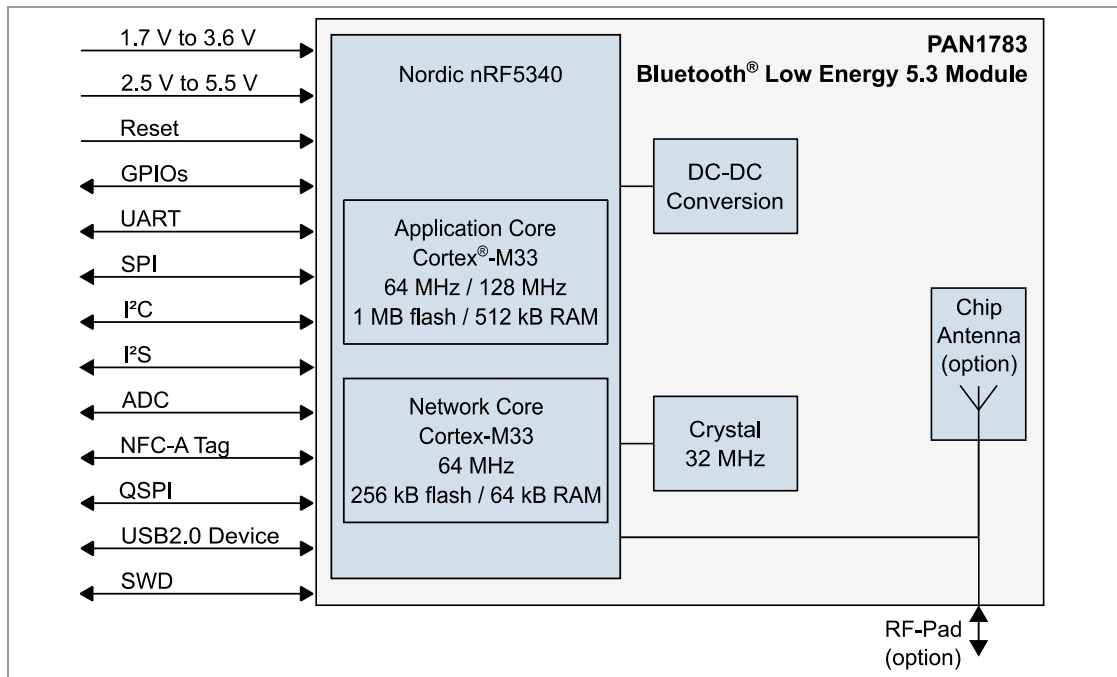

2.2 Pin Configuration

Pin Assignment

Top View

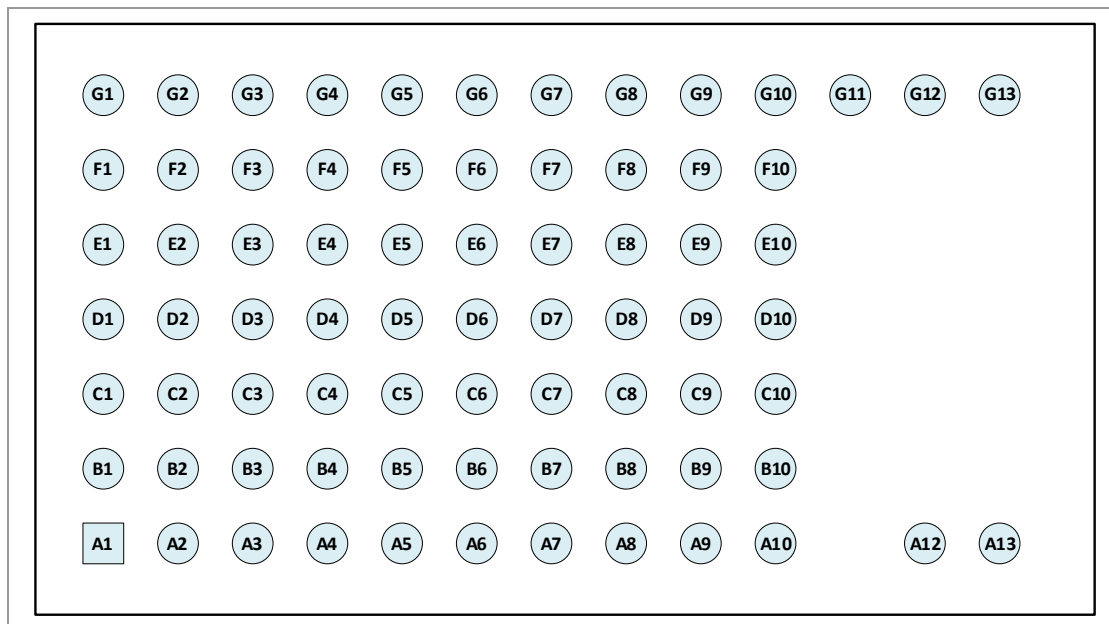

Pin Functions

No.	Pin Name	Pin Type	Description
A1	P0.29	Digital I/O	GPIO
A2	P1.00	Digital I/O	GPIO
A3	P0.28 / AIN7	Digital I/O / Analog Input	GPIO / Sensor to ADC
A4	P0.05 / AIN1	Digital I/O / Analog Input	GPIO / Sensor to ADC
A5	P0.04 / AIN0	Digital I/O / Analog Input	GPIO / Sensor to ADC
A6	P0.27 / AIN6	Digital I/O / Analog Input	GPIO / Sensor to ADC
A7	P0.26 / AIN5	Digital I/O / Analog Input	GPIO / Sensor to ADC
A8	P0.03 / NFC2	Digital I/O / NFC input	GPIO / NFC antenna connection
A9	P0.02 / NFC1	Digital I/O / NFC input	GPIO / NFC antenna connection
A10	GND	Ground	Connect to ground
A12	GND	Ground	Connect to ground
A13	GND	Ground	Connect to ground
B1	P1.01	Digital I/O	GPIO
B2	P0.01 / XL2	Digital I/O / Analog input	GPIO / Connection for 32 kHz crystal (option)
B3	P0.06 / AIN2	Digital I/O / Analog Input	GPIO / Sensor to ADC

No.	Pin Name	Pin Type	Description
B4	P0.07 / AIN3	Digital I/O / Analog Input	GPIO / Sensor to ADC
B5	P0.25 / AIN4	Digital I/O / Analog Input	GPIO / Sensor to ADC
B6	P0.24	Digital I/O	GPIO
B7	P0.19	Digital I/O	GPIO
B8	P1.08	Digital I/O	GPIO
B9	P0.22	Digital I/O	GPIO
B10	GND	Ground	Connect to ground
C1	P1.02	Digital I/O	GPIO
C2	P0.00 / XL2	Digital I/O / Analog input	GPIO / Connection for 32 kHz crystal (option)
C3	P1.03 / I2C	Digital I/O	GPIO
C4	GND	Ground	Connect to ground
C5	GND	Ground	Connect to ground
C6	P0.13/QSPI 0	Digital I/O / IO0 for QSPI	GPIO / Dedicated pin for Quad SPI
C7	P0.14 / QSPI 1	Digital I/O / IO1 for QSPI	GPIO / Dedicated pin for Quad SPI
C8	P0.15 / QSPI 2	Digital I/O / IO2 for QSPI	GPIO / Dedicated pin for Quad SPI
C9	P0.16 / QSPI 3	Digital I/O / IO3 for QSPI	GPIO / Dedicated pin for Quad SPI
C10	GND	Ground	Connect to ground
D1	GND	Ground	Connect to ground
D2	P0.21	Digital I/O	GPIO
D3	P0.12	Digital I/O	GPIO
	TRCCLK	Trace clock	Trace buffer clock
	DCX	DCX for SPIM4	Dedicated pin for high-speed SPI
D4	GND	Ground	Connect to ground
D5	GND	Ground	Connect to ground
D6	P1.10	Digital I/O	GPIO
D7	P0.18 / QSPI_CS	Digital I/O / CSN for QSPI	GPIO / Dedicated pin for Quad SPI
D8	P0.17 / QSPI_SCK	Digital I/O / SCK for QSPI	GPIO / Dedicated pin for Quad SPI
D9	GND	Ground	Connect to ground
D10	GND	Ground	Connect to ground
E1	VDD	Supply Voltage	1.7 V to 3.6 V
E2	P0.08	Digital I/O	GPIO
	TRCDAT3	Trace data	Trace buffer TRACEDATA[3]
	SCK	SCK for SPIM4	Dedicated pin for high-speed SPI

No.	Pin Name	Pin Type	Description
E3	GND	Ground	Connect to ground
E4	P0.23	Digital I/O	GPIO
E5	P1.06	Digital I/O	GPIO
E6	P1.07	Digital I/O	GPIO
E7	P1.09	Digital I/O	GPIO
E8	SWDCLK	Debug	Serial wire clock input for debug and programming
E9	P0.20	Digital I/O	GPIO
E10	P1.05	Digital I/O	GPIO
F1	P0.10	Digital I/O	GPIO
	TRCDATA1	Trace data	Trace buffer TRACEDATA[1]
	MISO	MISO for SPIM4	Dedicated pin for high-speed SPI
F2	P0.09	Digital I/O	GPIO
	TRCDATA2	Trace data	Trace buffer TRACEDATA[2]
	MOSI	MOSI for SPIM4	Dedicated pin for high-speed SPI
F3	P1.15	Digital I/O	GPIO
F4	P1.14	Digital I/O	GPIO
F5	P1.13	Digital I/O	GPIO
F6	P1.12	Digital I/O	GPIO
F7	P1.11	Digital I/O	GPIO
F8	P0.31	Digital I/O	GPIO
F9	P0.30	Digital I/O	GPIO
F10	GND	Ground	Connect to ground
G1	P1.04	Digital I/O	GPIO
G2	VDDH	Supply Voltage	2.5 V to 5.5 V (optional high voltage mode)
G3	GND	Ground	Connect to ground
G4	VBUS	USB Supply Voltage	Connect to 4.35 V to 5.5 V when using USB
G5	D+	USB D+	Use for USB only
G6	D-	USB D-	Use for USB only
G7	nRESET	Digital I	Reset Signal Low Active
G8	P0.11	Digital I/O	GPIO
	TRCDATA0	Trace data	Trace buffer TRACEDATA[0]
	CSN	CSN for SPIM4	Dedicated pin for high-speed SPI
G9	SWDIO	Debug	Serial wire I/O input for debug and programming

No.	Pin Name	Pin Type	Description
G10	GND	Ground	Connect to ground
G11	NC	NC	Do not connect for PAN1783 (ENW89860A1KF)
	RF_PIN	Analog I/O	RF in/out for PAN1773 (ENW89860C1KF)
G12	GND	Ground	Connect to ground
G13	GND	Ground	Connect to ground

2.3 Peripherals

- 12 Mbps full-speed USB 2.0 device controller
- Up to 4x UART with EasyDMA, 2 or 4 wire with CTS/RTS, 1 200 up to 1 M baud
- Up to 4x I²C compatible two-wire master/slave with EasyDMA, 100 kbps up to 1 000 kbps
- Audio peripherals – I²S, digital microphone interface (PDM)
- 32 MHz high-speed SPI
- 4x SPI master/slave with EasyDMA SPI
- QSPI (96 MHz)
- 4x PWM
- 8-Channels 12-bit ADC, 200 kSPS
- Low-power comparator, general-purpose comparator
- 2x QDEC – Quadrature decoder
- Temperature sensor
- Two 24-bit real-time counters (RTC)
- Watchdog timer
- 48x GPIOs
- AES and CryptoCell

2.4 Bluetooth Features

- LE Audio: audio streaming over Bluetooth LE, multi-stream synchronized audio and Audio Sharing
- Long range
- High-through-put 2 Mbps and Advertising Extensions features
- Bluetooth mesh

3 Detailed Description

3.1 Dimensions



The dimensions are in millimeters.

Top View

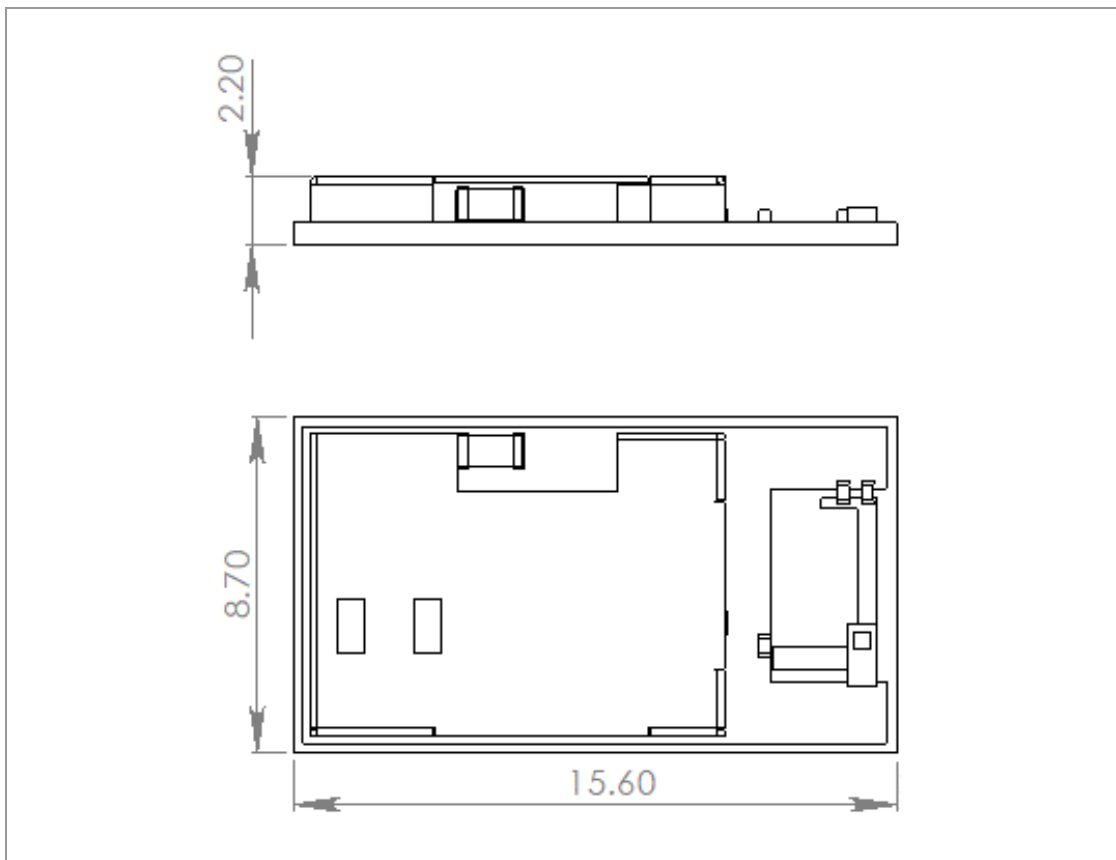

Item	Dimension	Tolerance	Remark
Width	8.70	±0.30	
Length	15.60	±0.30	
Height	2.20	±0.30	With case

3.2 Footprint



All dimensions are in millimeters.

Top View

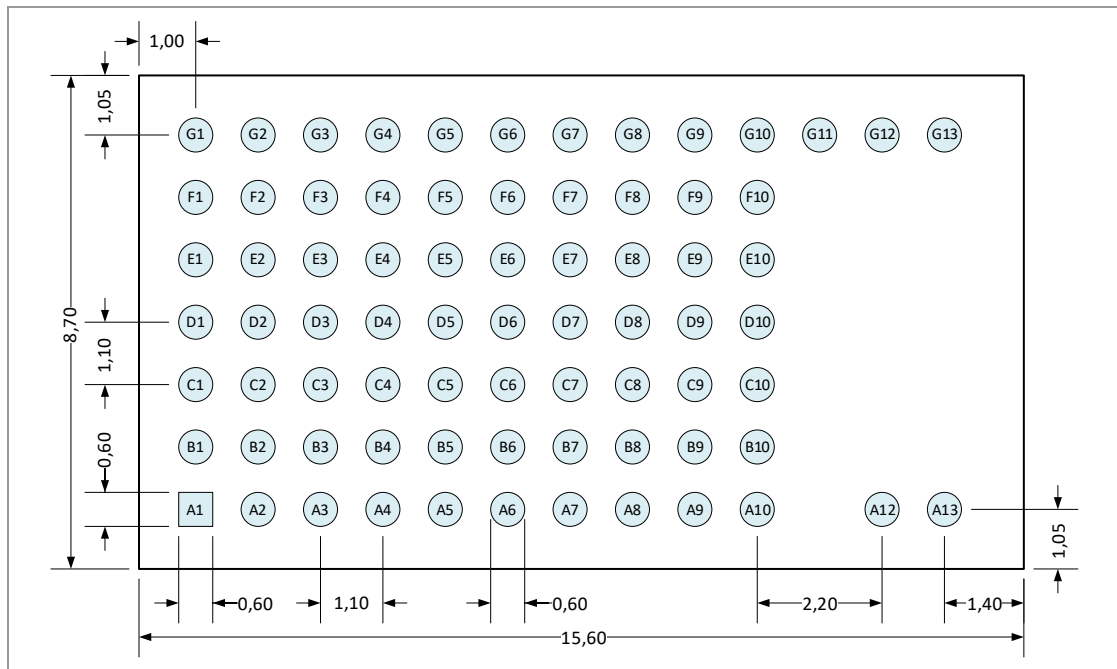

3.3 Packaging

The module is a mass production status product and will be delivered in the package described below.

3.3.1 Tape Dimensions

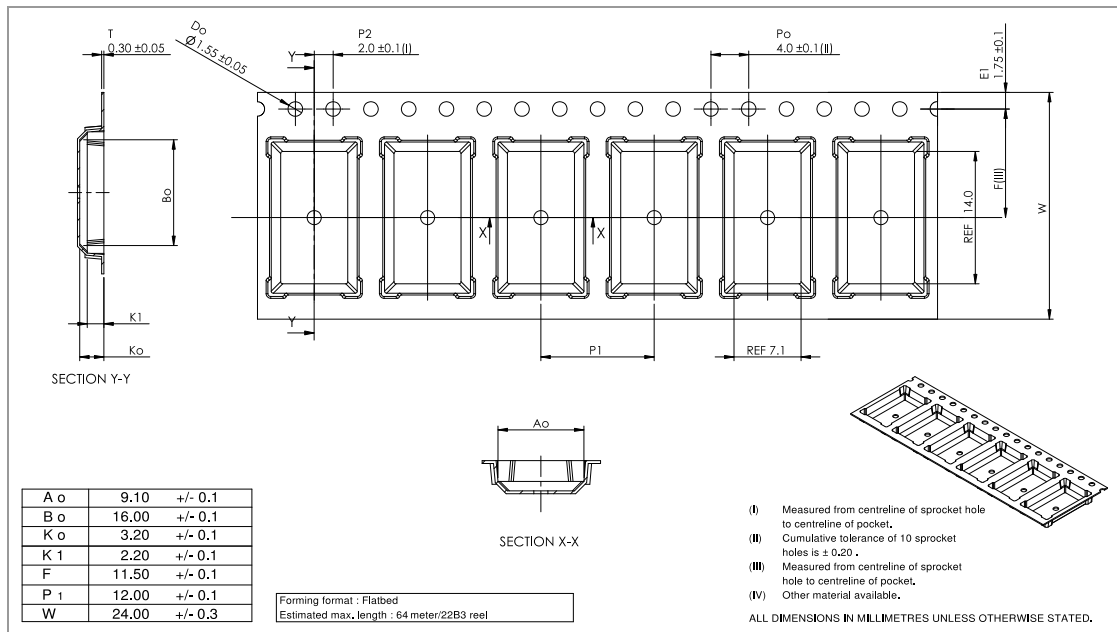

3.3.2 Packing in Tape

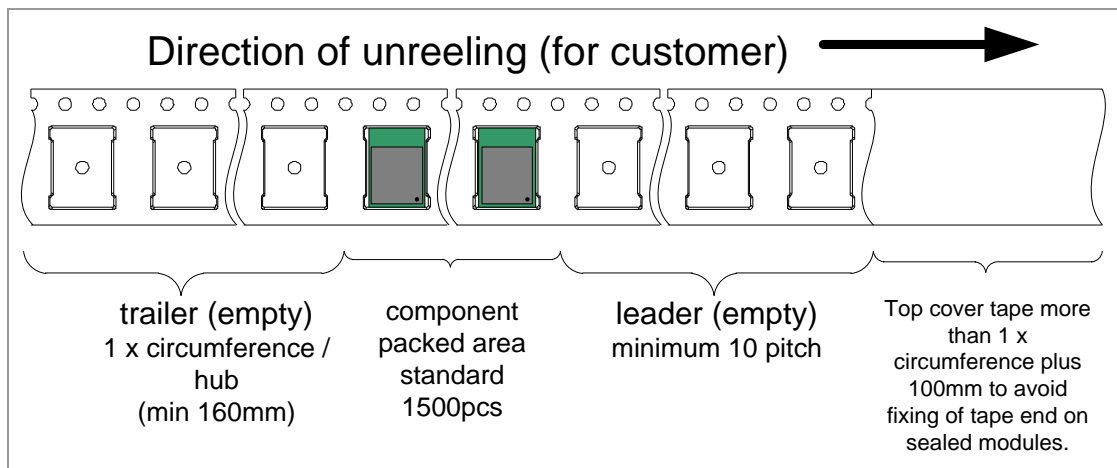

Empty spaces in the component packed area shall be less than two per reel and those spaces shall not be consecutive.

The top cover tape shall not be found on reel holes and it shall not stick out from the reel.

3.3.3 Component Direction

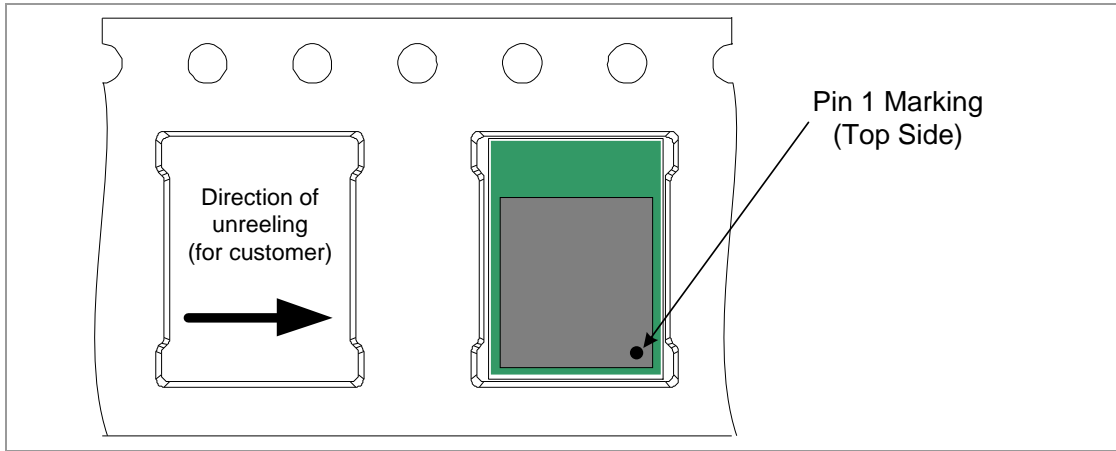

3.3.4 Reel Dimension

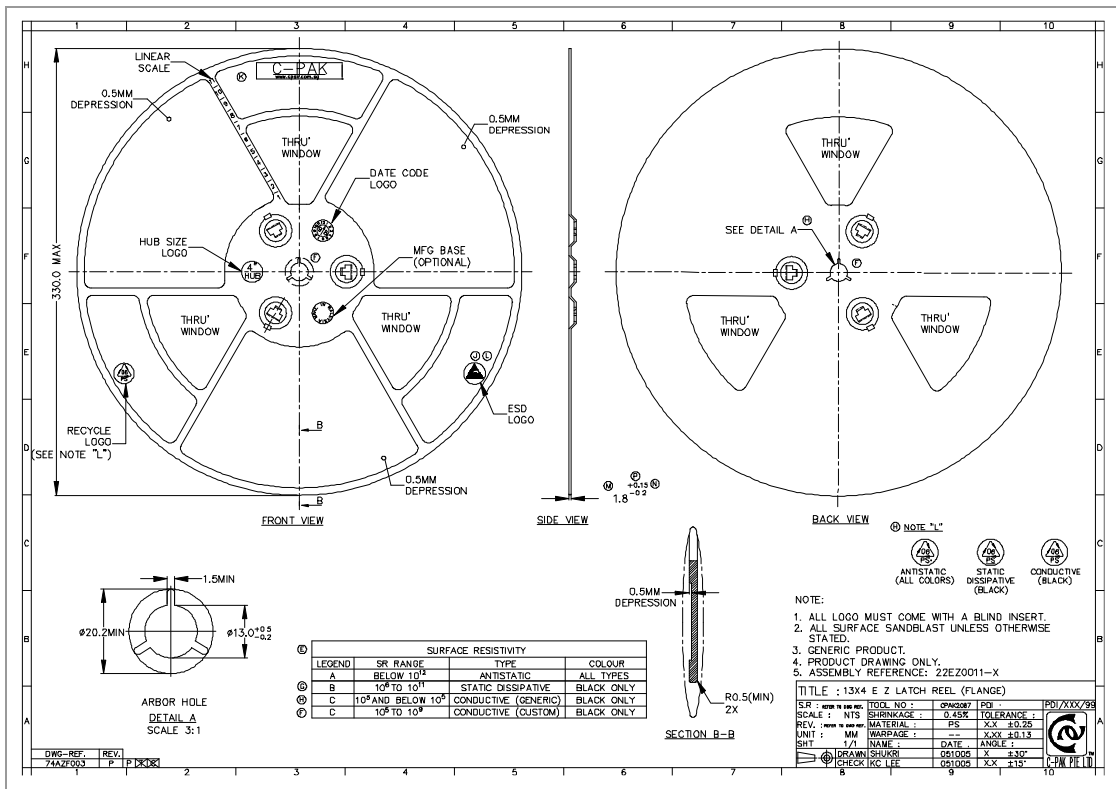

3.3.5 Package Label

Example:

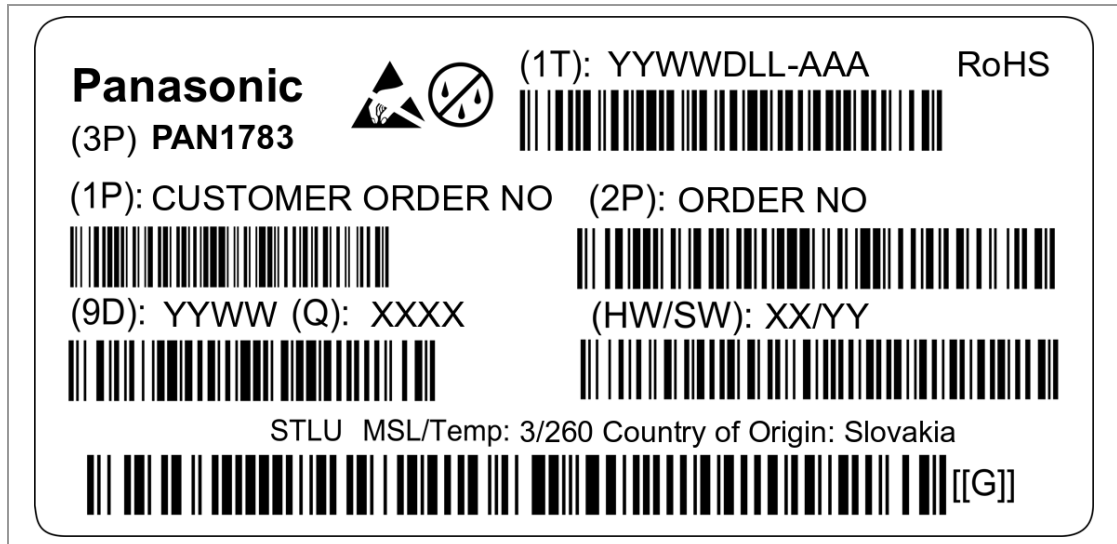

(1T)	Lot code
(1P)	Customer order number, if applicable
(2P)	Order number
(9D)	Date code
(Q)	Quantity
(HW/SW)	Hardware/software version

3.3.6 Total Package

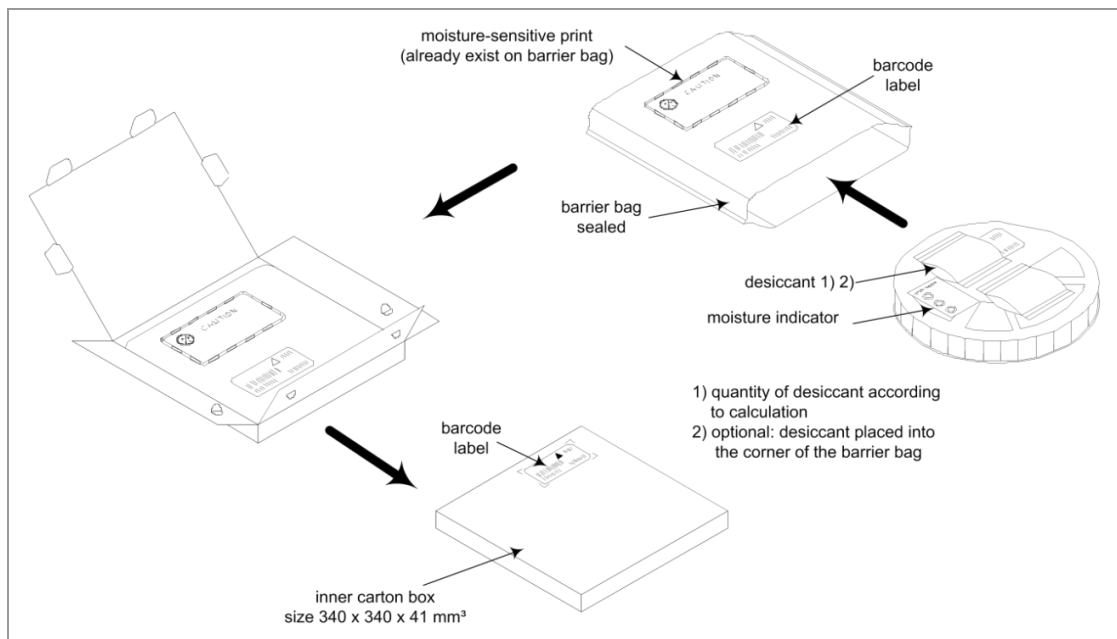

3.4 Case Marking

Example:

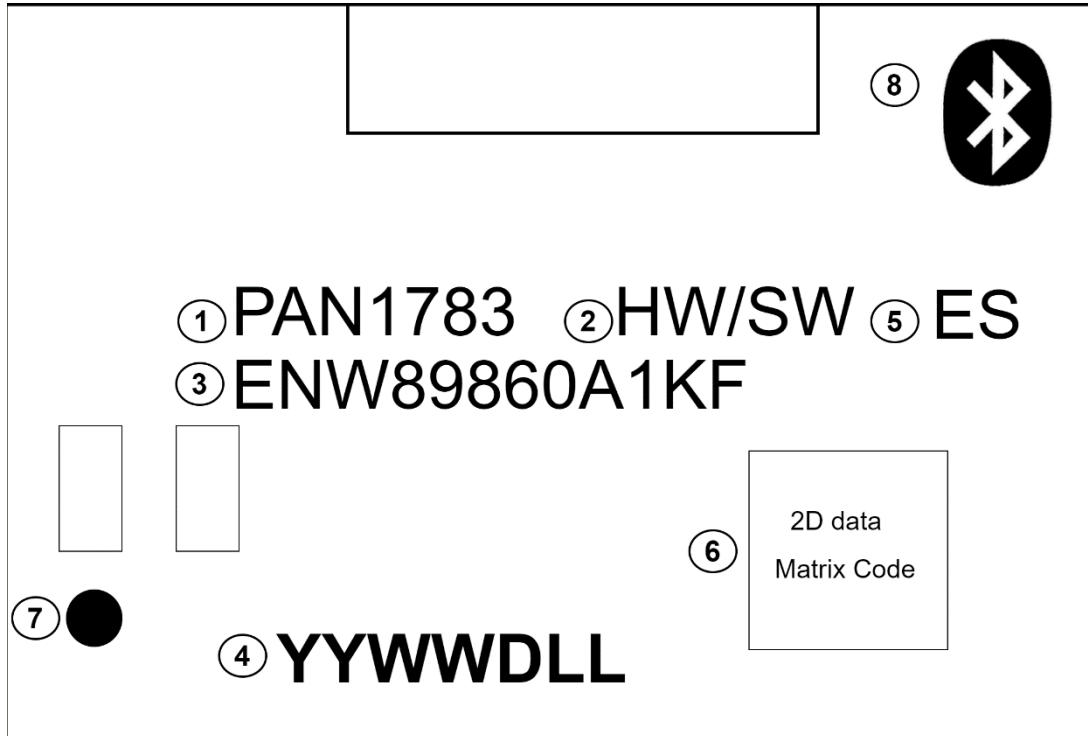

- 1 Brand name
- 2 Hardware/software version
- 3 Order number
- 4 Lot code
- 5 Status: ES or empty for MP
- 6 2D barcode, for internal usage only
- 7 Marking for Pin 1
- 8 Bluetooth logo

4 Specification and Integration Recommendations



All specifications are over temperature and process, unless indicated otherwise.

4.1 Default Test Conditions



Temperature: 25 °C ± 10 °C
 Humidity: 40 % to 85 % RH
 Supply Voltage: 3 V

4.2 Absolute Maximum Ratings



The maximum ratings may not be exceeded under any circumstances, not even momentarily or individually, as permanent damage to the module may result.

Symbol	Parameter	Condition	Min.	Typ.	Max.	Unit
V _{DD}	Normal Supply Voltage		-0.3		+3.9	V
V _{DDH}	High Supply Voltage		-0.3		+5.8	
V _{BUS}	USB Bus Voltage		-0.3		+5.8	
I/O Pin	Voltage on any Pin	V _{DD} ≤ 3.6 V	-0.3		V _{DD} + 0.3	
		V _{DD} > 3.6 V	-0.3		3.9	
ESD	ESD Robustness	HBM 1C			1 000	
		CDM			500	
MSL	Moisture Sensitivity Level				3	
P _{RF}	RF Input Level				+10	dBm
T _{STOR}	Storage Temperature		-40		+85	°C

4.3 Recommended Operating Conditions



The maximum ratings may not be exceeded under any circumstances, not even momentarily or individually, as permanent damage to the module may result.

Symbol	Parameter	Condition	Min.	Typ.	Max.	Unit
V _{DD} (LV Mode)	Supply Voltage		1.7	3.0	3.6	V
V _{DDH} (HV Mode)	Supply Voltage	V _{DDH} - Optional	2.5	3.7	5.5	V
V _{BUS}	V _{BUS} USB Supply Voltage	V _{BUS} - Optional	4.35	5.0	5.5	V
TA	Operating Temperature		-40	25	85	°C

4.4 Current Consumption



The current consumption depends on the user scenario and on the setup and timing in the power modes.

Assume V_{DD} = 3 V, T_{amb} = 25 °C, if nothing else stated, DC-DC enabled.

Parameter	Condition	Min.	Typ.	Max.	Unit
Sleep Mode	System OFF, wake on reset		0.9		μA
	System ON, wake on any event		1.3		μA
	System OFF, 512 kB application RAM + 64 kB network RAM, wake on reset		2.4		μA
CPU executing CoreMark	Application CPU running, CoreMark from flash		3.3		mA
	Application CPU running, CoreMark from RAM		3.5		mA
	Network CPU running, CoreMark from flash		2.4		mA
	Network CPU running, CoreMark from RAM		2.0		mA
Rx Current	1 Mbps Bluetooth low energy (BLE) mode, clock = HFXO64M		3.7		mA
Tx Current	+3 dBm output power, 1 Mbps Bluetooth low energy (BLE) mode, clock = HFXO64M		5.3		mA
	0 dBm output power, 1 Mbps Bluetooth low energy (BLE) mode, clock = HFXO64M		4.1		mA
	-40 dBm output power, 1 Mbps Bluetooth low energy (BLE) mode, clock = HFXO64M		2.6		mA

4.5 Bluetooth

Parameter	Specification
Frequency	2 402 MHz to 2 480 MHz
Data Rate	2 Mbps, 1 Mbps, 500 kbps, 125 kbps
Number of Channels	40: 37 data/3 advertising (0, 12, 39)
Receive Sensitivity	-104 dBm (125 kbps Bluetooth LE mode), -98 dBm (1 Mbps Bluetooth LE mode), -95 (2 Mbps Bluetooth LE mode)
Output Power	-40 dBm to 3 dBm
Link Budget	Up to 107 dB

4.6 Access Port Protection APPROTECT

If using Access Port Protection (APPROTECT) please refer to the “nRF5340 Product Specification” in the Nordic Infocenter <https://infocenter.nordicsemi.com/>.

4.7 Antenna Placement Recommendation



Antenna “Keep out Area”

Do not place any ground plane under the marked restricted antenna area in any layer! This would be affecting the performance of the chip antenna in a critical manner.



Impact of Placement on the Antenna Radiation Pattern

The placement of the module, surrounding material, and customer components has an impact on the radiation pattern of the antenna.



The recommendation for the ground plane is based on a FR4 4-Layer PCB.

The following requirements must be met:

- ✓ Keep this product away from heat. Heat is the major cause of decreasing the life of these products.
- ✓ Keep this product away from other high frequency circuits.

The antenna requires a cutout area of 5 mm × 3 mm under the PAN1783 module. This “Keep out Area” shall be located in every layer under the module antenna. Note for example the “Keep out Area” in all four layers of the PAN1783 evaluation board.

It is recommended to verify the perfect position of the module in the target application before fixing the design.

Antenna Placement Recommendation



All dimensions are in millimeters.



Use a ground plane in the area surrounding the module wherever possible.

It is recommended to place the module:

- In the center (horizontal) of any mother PCB edge
- GND plane on the left and right of the module

Top View

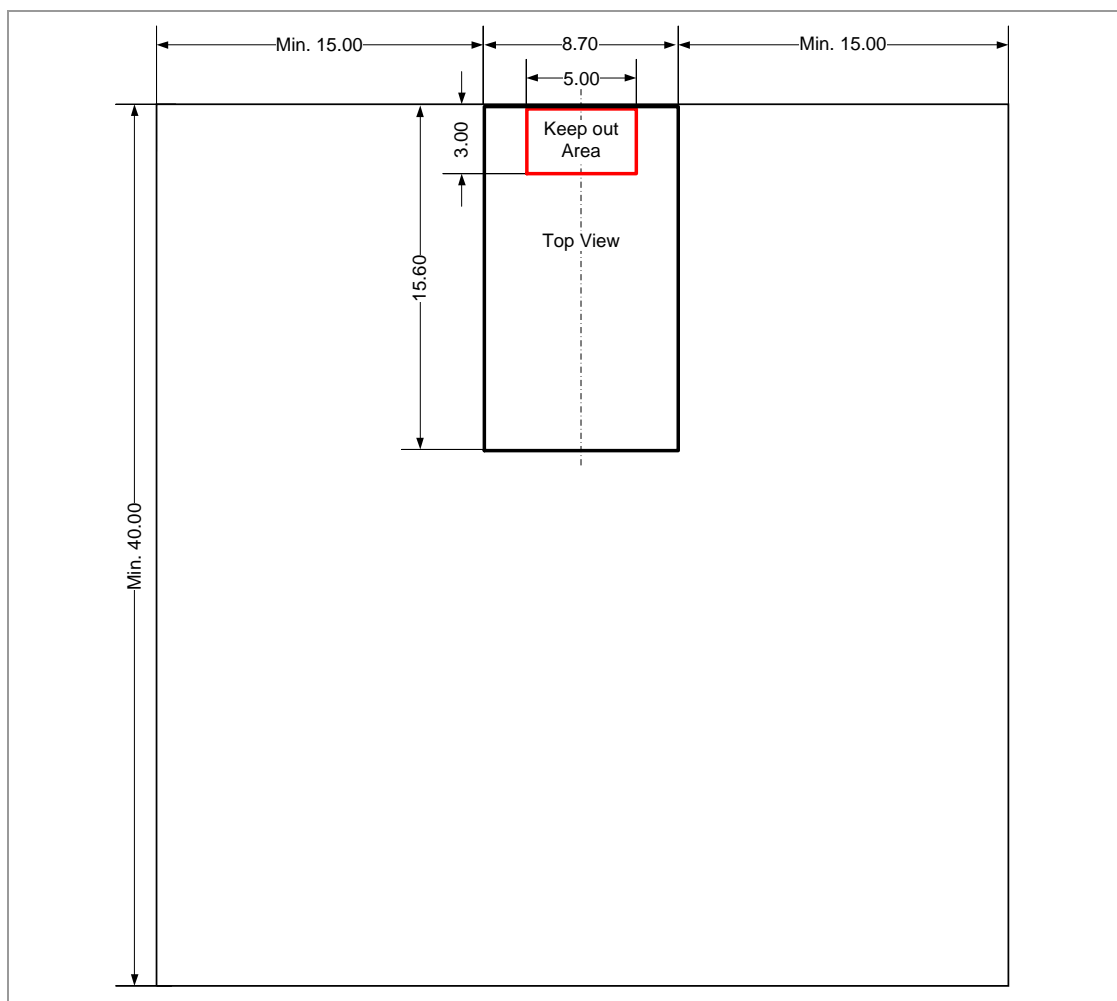

4.8 Reliability Tests

The measurement should be done after the test module has been exposed to room temperature and humidity for one hour.

No.	Item	Limit	Condition
1	Variable Vibration Test	Electrical parameters should be within specification	Freq.: 20~2 000 Hz, Acc.: 17-50 G, Sweep: 8 min, 2 hours, For: XYZ axis
2	Shock Drop Test		Drop parts on concrete from a height of 1 m for 3 times
3	Temperature Cycling Test		At -40 °C and 85 °C for 1 h/cycle Total = 300 cycles
4	Temperature Humidity Bias Test		At 60 °C, 85 % r.H., 300 h
5	Low Temperature Storage Life Test		At -40 °C, 300 h
6	High Temperature Storage Life Test		At 85 °C, 300 h

4.9 Recommended Soldering Profile



- Reflow permissible cycles: 2
- Opposite side reflow is prohibited due to module weight
- More than 75 percent of the soldering area shall be coated by solder
- The soldering profiles should be adhered to in order to prevent electrical or mechanical damage
- Soldering profile assumes lead-free soldering

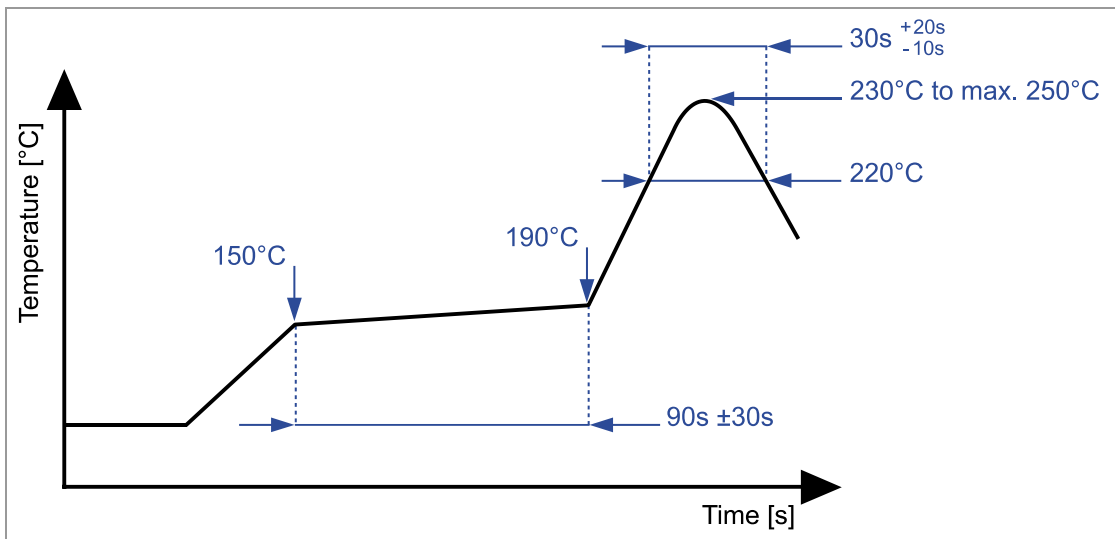

5 Cautions



Failure to follow the guidelines set forth in this document may result in degrading of the module functions and damage to the module.

5.1 Design Notes

1. Follow the conditions written in this specification, especially the control signals of this module.
2. The supply voltage should abide by the maximum ratings (⇒ [4.2 Absolute Maximum Ratings](#)).
3. The supply voltage must be free of AC ripple voltage (for example from a battery or a low noise regulator output). For noisy supply voltages, provide a decoupling circuit (for example a ferrite in series connection and a bypass capacitor to ground of at least 47 μF directly at the module).
4. This module should not be mechanically stressed when installed.
5. Keep this module away from heat. Heat is the major cause of decreasing the life time of these modules.
6. Avoid assembly and use of the target equipment in conditions where the module temperature may exceed the maximum tolerance.
7. Keep this module away from other high frequency circuits.
8. Refer to the recommended pattern when designing a board.

5.2 Installation Notes

1. Reflow soldering is possible twice based on the conditions set forth in ⇒ [4.9 Recommended Soldering Profile](#). Set up the temperature at the soldering portion of this module according to this reflow profile.
2. Carefully position the module so that the heat will not burn into printed circuit boards or affect other components that are susceptible to heat.
3. Carefully locate the module, to avoid an increased temperature caused by heat generated by neighboring components.
4. If a vinyl-covered wire comes into contact with the module, the wire cover will melt and generate toxic gas, damaging the insulation. Never allow contact between a vinyl cover and these modules to occur.
5. This module should not be mechanically stressed or vibrated when reflowed.
6. To repair the board by hand soldering, follow the conditions set forth in this chapter.
7. Do not wash this product.
8. Pressing on parts of the metal cover or fastening objects to the metal will cause damage to the module.

5.3 Usage Condition Notes

1. Take measures to protect the module against static electricity.
If pulses or transient loads (a large load, which is suddenly applied) are applied to the modules, check and evaluate their operation before assembly of the final products.
2. Do not use dropped modules.
3. Do not touch, damage, or soil the pins.
4. Follow the recommended condition ratings about the power supply applied to this module.
5. Electrode peeling strength: Do not apply a force of more than 4.9 N in any direction on the soldered module.
6. Pressing on parts of the metal cover or fastening objects to the metal cover will cause damage.
7. These modules are intended for general purpose and standard use in general electronic equipment, such as home appliances, office equipment, information, and communication equipment.

5.4 Storage Notes

1. The module should not be stressed mechanically during storage.
2. Do not store these modules in the following conditions or the performance characteristics of the module, such as RF performance will be adversely affected:
 - Storage in salty air or in an environment with a high concentration of corrosive gas, such as Cl₂, H₂S, NH₃, SO₂, or NO_x,
 - Storage in direct sunlight,
 - Storage in an environment where the temperature may be outside the range of 5 °C to 35 °C, or where the humidity may be outside the 45 % to 85 % range,
 - Storage of the modules for more than one year after the date of delivery storage period: Please check the adhesive strength of the embossed tape and soldering after 6 months of storage.
3. Keep this module away from water, poisonous gas, and corrosive gas.
4. This module should not be stressed or shocked when transported.
5. Follow the specification when stacking packed crates (max. 10).

5.5 Safety Cautions

These specifications are intended to preserve the quality assurance of products and individual components.

Before use, check and evaluate the operation when mounted on your products. Abide by these specifications without deviation when using the products. These products may short-circuit. If electrical shocks, smoke, fire, and/or accidents involving human life are anticipated when a short circuit occurs, provide the following failsafe functions as a minimum:

1. Ensure the safety of the whole system by installing a protection circuit and a protection device.
2. Ensure the safety of the whole system by installing a redundant circuit or another system to prevent a single fault causing an unsafe status.

5.6 Other Cautions

1. Do not use the module for other purposes than those listed in section ⇒ [5.3 Usage Condition Notes](#).
2. Be sure to provide an appropriate fail-safe function on your product to prevent any additional damage that may be caused by the abnormal function or the failure of the module.
3. This module has been manufactured without any ozone chemical controlled under the Montreal Protocol.
4. These modules are not intended for use under the special conditions shown below. Before using these modules under such special conditions, carefully check their performance and reliability under the said special conditions to determine whether or not they can be used in such a manner:
 - In liquid, such as water, salt water, oil, alkali, or organic solvent, or in places where liquid may splash,
 - In direct sunlight, outdoors, or in a dusty environment,
 - In an environment where condensation occurs,
 - In an environment with a high concentration of harmful gas (e. g. salty air, HCl, Cl₂, SO₂, H₂S, NH₃, and NO_x).
5. If an abnormal voltage is applied due to a problem occurring in other components or circuits, replace these modules with new modules, because they may not be able to provide normal performance even if their electronic characteristics and appearances appear satisfactory.



For further information please refer to the Panasonic website ⇒ [7.2.2 Product Information](#).

5.7 Restricted Use

5.7.1 Life Support Policy

This Panasonic Industrial Devices Europe GmbH product is not designed for use in life support appliances, devices, or systems where malfunction can reasonably be expected to result in a significant personal injury to the user, or as a critical component in any life support device or system whose failure to perform can be reasonably expected to cause the failure of the life support device or system, or to affect its safety or effectiveness.

Panasonic customers using or selling these products for use in such applications do so at their own risk and agree to fully indemnify Panasonic Industrial Devices Europe GmbH for any damages resulting.

5.7.2 Restricted End Use

This Panasonic Industrial Devices Europe GmbH product is not designed for any restricted activity that supports the development, production, handling usage, maintenance, storage, inventory or proliferation of any weapons or military use.

Transfer, export, re-export, usage or reselling of this product to any destination, end user or any end use prohibited by the European Union, United States or any other applicable law is strictly prohibited.

6 Regulatory and Certification Information

This chapter contains regulatory and certification information for:

- Bluetooth Low Energy ⇒ [6.1 For Bluetooth Low Energy](#)
- IEEE 802.15.4 ⇒ [6.2 For IEEE 802.15.4](#)

6.1 For Bluetooth Low Energy

6.1.1 General Certification Information

tbd

6.1.2 Federal Communications Commission (FCC) for US

tbd

6.1.3 Innovation, Science, and Economic Development (ISED) for Canada

tbd

6.1.4 European Conformity According to RED (2014/53/EU)

tbd

6.1.5 Bluetooth

The final Bluetooth end product listing needs to be created by using the following IDs:

Bluetooth 5.1	Declaration ID	QDID
End product	tbd	tbd

Bluetooth 5.3	Declaration ID	QDID
End product	tbd	tbd

Bluetooth Marks

According to the Bluetooth SIG, the PAN1783 fulfills the criteria to label your product as a Bluetooth device:



For further information please refer to the Bluetooth website www.bluetooth.com.

6.2 For IEEE 802.15.4

6.2.1 General Certification Information

tbd

6.2.2 Federal Communications Commission (FCC) for US

tbd

6.2.3 Innovation, Science, and Economic Development (ISED) for Canada

tbd

6.2.4 European Conformity According to RED (2014/53/EU)

tbd

6.3 RoHS and REACH Declaration

The latest declaration of environmental compatibility (Restriction of Hazardous Substances, RoHS and Registration, Evaluation, Authorisation and Restriction of Chemicals, REACH) for supplied products can be found on the Panasonic website in the “Downloads” section of the respective product ⇒ [7.2.2 Product Information](#).

7 Appendix

7.1 Ordering Information

Variants and Versions

Order Number	Brand Name	Description	MOQ ¹
ENW89860A1KF ²	PAN1783	Bluetooth Low Energy Module with Antenna Empty Flash	1 500
ENW89860C1KF ²	PAN1773	Bluetooth Low Energy Module with Bottom-pad Empty Flash	1 500

¹ Abbreviation for Minimum Order Quantity (MOQ). The default MOQ for mass production is 1 500 pieces, fewer only on customer demand. Samples for evaluation can be delivered at any quantity via the distribution channels.

² Samples available on customer demand

7.2 Contact Details

7.2.1 Contact Us

Please contact your local Panasonic Sales office for details on additional product options and services:

For Panasonic Sales assistance in the **EU**, visit

<https://eu.industrial.panasonic.com/about-us/contact-us>

Email: wireless@eu.panasonic.com

For Panasonic Sales assistance in **North America**, visit the Panasonic website “Sales & Support” to find assistance near you at

<https://na.industrial.panasonic.com/distributors>

Please visit the **Panasonic Wireless Technical Forum** to submit a question at

<https://forum.na.industrial.panasonic.com>

7.2.2 Product Information

Please refer to the Panasonic Wireless Connectivity website for further information on our products and related documents:

For complete Panasonic product details in the **EU**, visit

<http://pideu.panasonic.de/products/wireless-modules.html>

For complete Panasonic product details in **North America**, visit

<http://www.panasonic.com/rfmodules>