

18 mm Square Encoders (Water proof Type)

Type: **EVQV9**

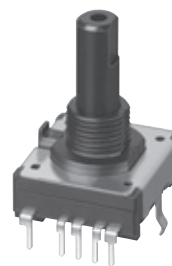

■ Features

- Water resistant
- Highly responsive clicking
- High precision and reliability
(uses the insertion contact method)

■ Recommended Applications

- Home appliances, AV equipment, etc.
(for signal input)

■ Explanation of Part Numbers

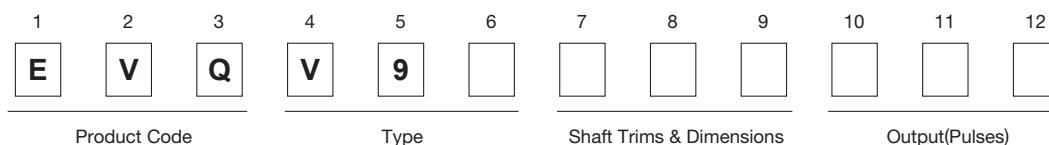

■ Specifications

Mechanical	Rotation Angle	360 ° (Endless)	
	Shaft Pull/Push Strength	100 N min.	
	Shaft Wobble	(Each side: 0.5 × L/30(mm)max.) Applied 50 mN·m moment L=Length from mounting surface	
	Rotation Torque	50±20 mN·m	
	Detents	8 points	16 points
Electrical	Output Signal	8 positions	16 positions
	Resolution	Absolute 3-bit , Gray code absolute	Absolute 4-bit , Gray code absolute
	Rating	1 mA 10 V DC	
	Contact Resistance	10 Ω max.	
	Insulation Resistance	50 MΩ min. (at 250 V DC)	
	Dielectric Withstanding Voltage	50 V AC for 1 minute	
Endurance	Bouncing	5 ms max.	
	Rotation Life	30,000 cycles min.	
Minimum Quantity / Packing Unit		120 pcs.(Tray Pack)	
Quantity / Carton		1,200 pcs.	

Design and specifications are each subject to change without notice. Ask factory for the current technical specifications before purchase and/or use.
Should a safety concern arise regarding this product, please be sure to contact us immediately.

■ Dimensions in mm (not to scale)

EVQV9 General dimension tolerance : ± 0.5
 () dimensions are reference dimensions.

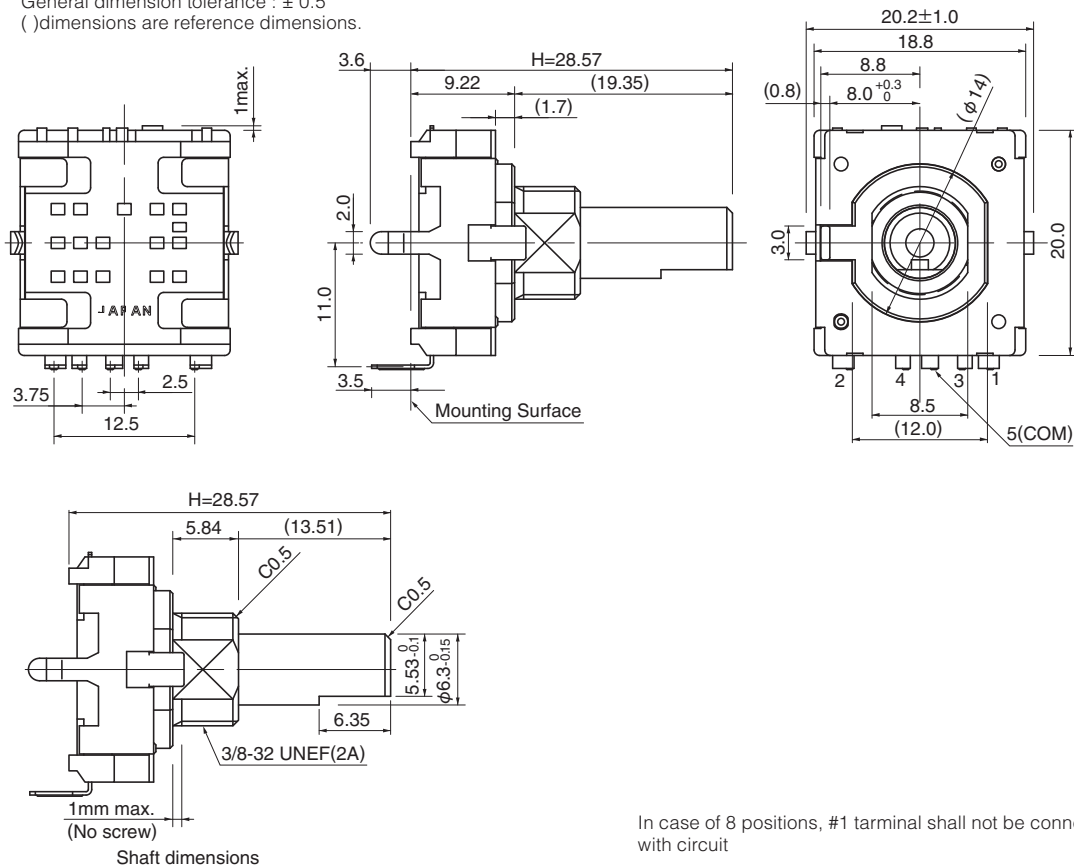

■ PWB mounting hole for reference

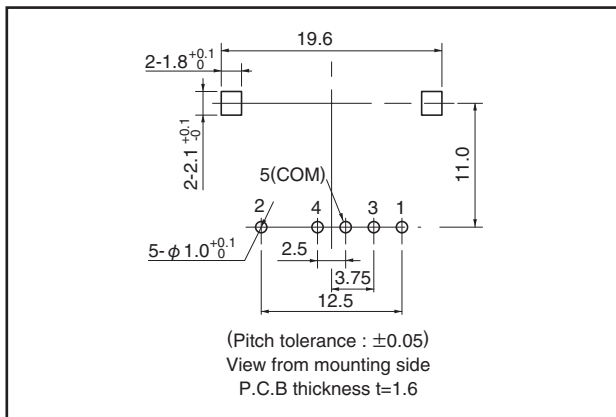

■ Circuit Diagram

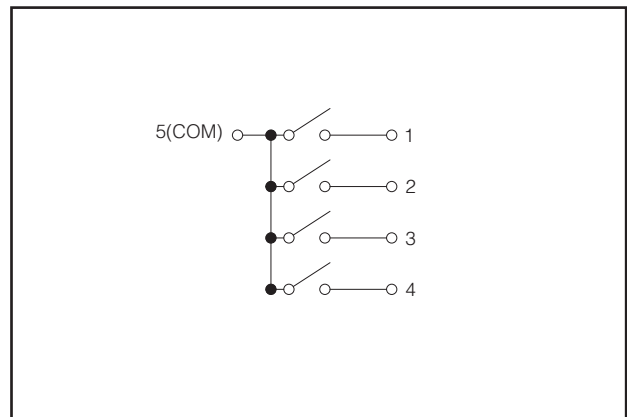

■ Test Circuit Diagram

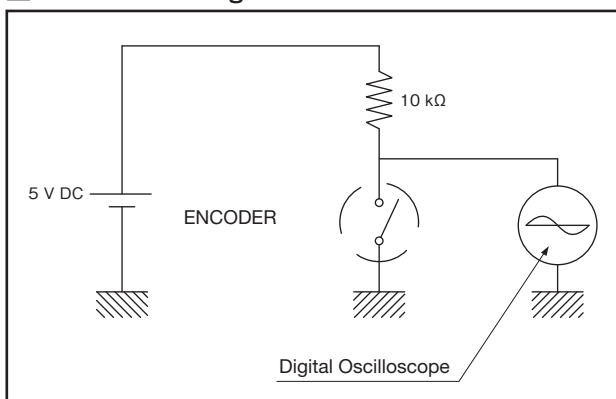

Design and specifications are each subject to change without notice. Ask factory for the current technical specifications before purchase and/or use.
 Should a safety concern arise regarding this product, please be sure to contact us immediately.