

## 27/17 mm Center Space Encoders

Type: **EVQWF/EVQVP**



### ■ Features

- Multiple unit construction (achieved by mounting switches, LEDs, etc.) (center space) on the printed wiring board
- Good operability and high reliability

### ■ Recommended Applications

- Car audio products (adjustment of volume, tone, tuners, etc.)
- AV equipment (control of edit functions of VCRs, CD players, etc.)

### ■ Explanation of Part Numbers

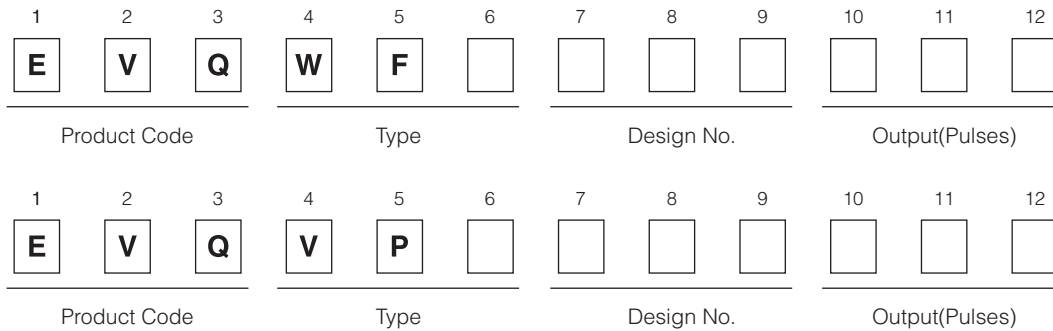

### ■ Specifications

Mechanical	Rotation Angle	360 ° (Endless)
	Rotation Torque (Detents Torque)	8 mN·m, 12 mN·m, 20 mN·m
	Detents	18 points, 30 points
Electrical	Output Signal	Phase A and B
	Resolution	9 pulses/360 °, 15 pulses/360 °
	Rating	1 mA 10 V DC
	Contact Resistance	1 Ω max.
	Chattering	5 ms max.
	Insulation Resistance	50 mΩ min. (at 250 V DC)
	Dielectric Withstanding Voltage	300 V AC for 1 minute
Endurance	Rotation Life	30,000 cycles min.
Minimum Quantity/Packing Unit		80 pcs. (Tray Pack)
Quantity/Carton		800 pcs.

### ■ Dimensions in mm (not to scale)

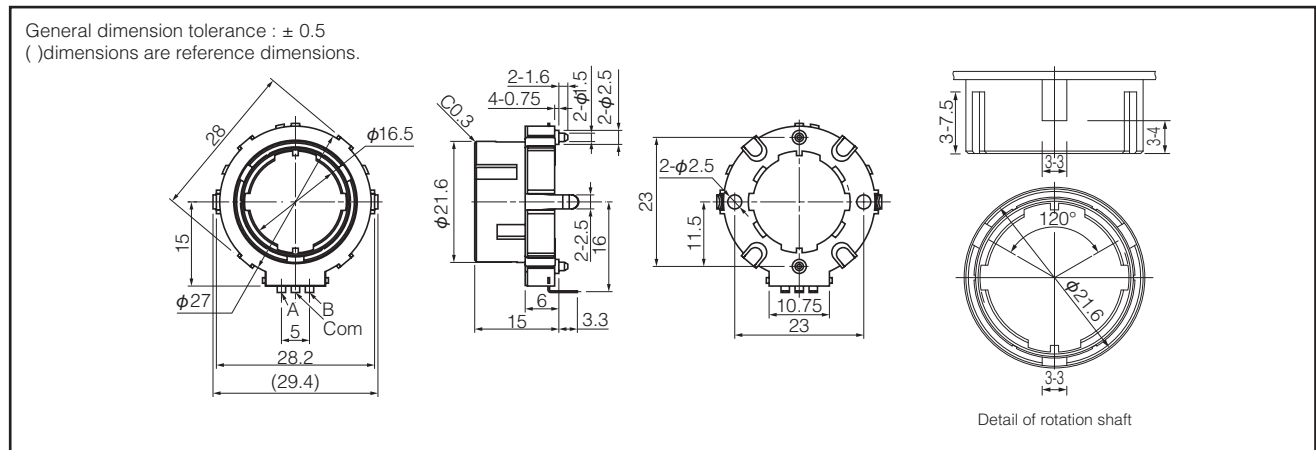

Design and specifications are each subject to change without notice. Ask factory for the current technical specifications before purchase and/or use. Should a safety concern arise regarding this product, please be sure to contact us immediately.

### ■ PWB mounting hole for reference

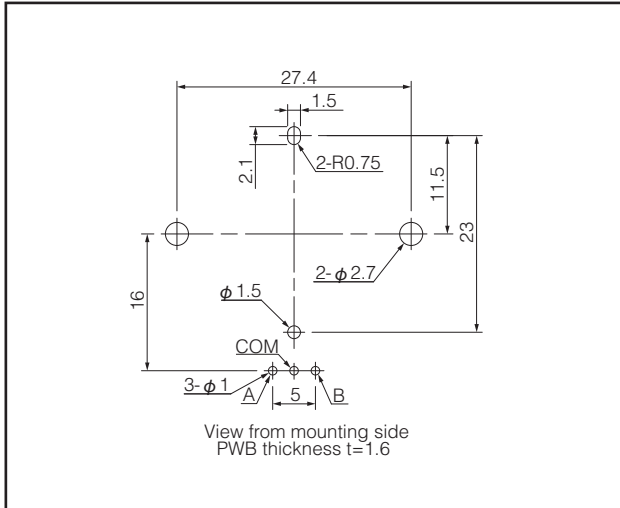

### ■ Circuit Diagram

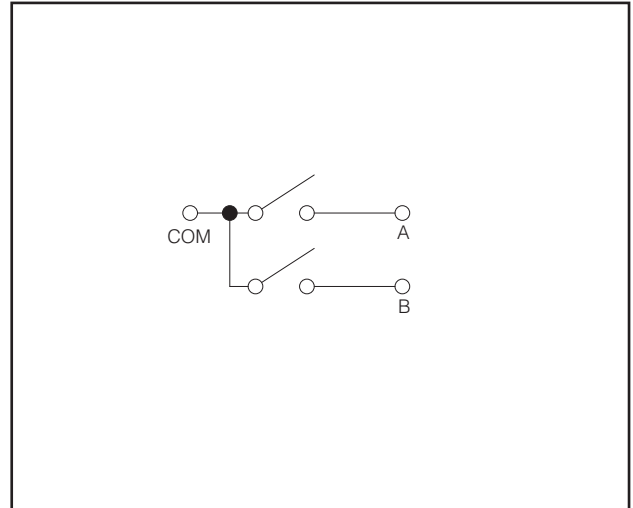

### ■ Phase Difference

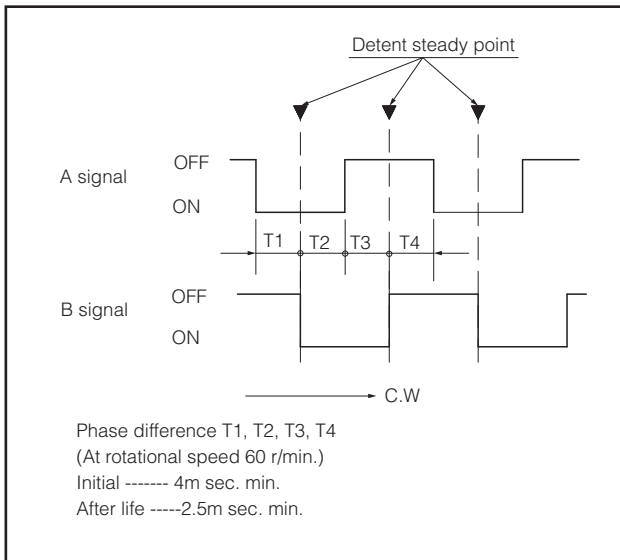

### ■ Test Circuit Diagram

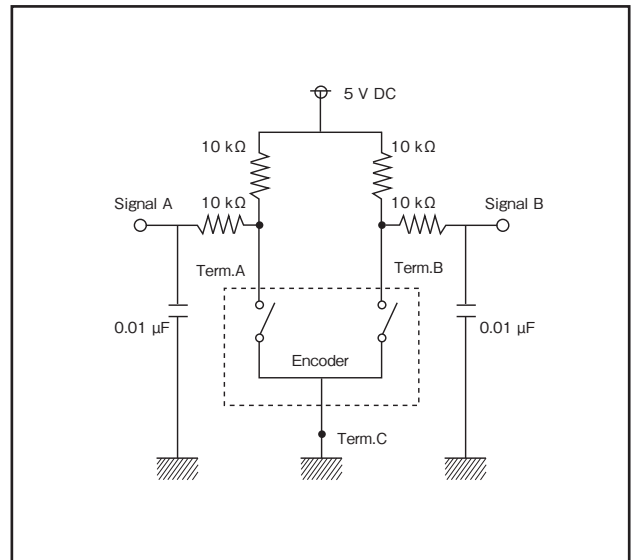

Design and specifications are each subject to change without notice. Ask factory for the current technical specifications before purchase and/or use.  
Should a safety concern arise regarding this product, please be sure to contact us immediately.