

High-frequency AC Method

## Pulse Air-gun Ionizer EC-G02



# EC-G02



CE

**Air-gun type ionizer that can remove dust in a single burst using pulsed ion air**

### Three discharge modes



The **EC-G02** features two pulse air modes in addition to the standard continuous mode.

### White LED illumination



The **EC-G02** features a high-brightness white LED above the ionized air outlet, allowing you to target and spray dust revealed by the light with a stream of ionized air.

### Compact, highly usable design

A high-voltage power supply circuit and solenoid valve are built into the air gun, providing a high level of usability and eliminating the need to install an external controller or route thick, high-voltage cables. Additionally, since the lightweight unit weighs just 270 g, it reduces stress on the operator, even when used for extended periods of time.

### Improved dust removal effectiveness thanks to pulse (intermittent) air

Since pulse air causes dust to oscillate and lifts it up, even difficult-to-dislodge dust inside concave pockets can be easily removed. The **EC-G02** can deliver greater dust removal effectiveness than continuous airflow models.

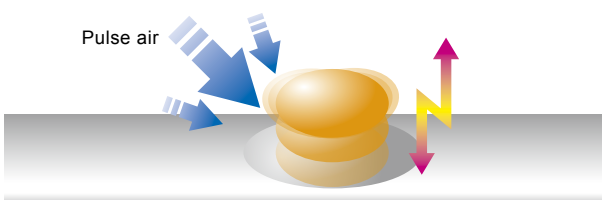

### External input

External input allows the unit to be used in combination with a foot switch or other device.

### No-oil compliance

All parts along the air path (air nozzle, solenoid valve, joints, etc.) are no-oil compliant.

## ORDER GUIDE

Type	Charge removal time (±1,000 V → ±100 V)	Model No.
Gun type	0.5 sec. approx. or less (Note)	<b>EC-G02</b>

Note: Typical value for pulse air mode: CONT at 100 mm **3.937 in** from the front of discharge nozzle at an applied air pressure of 0.50 MPa.

## SPECIFICATIONS

Type	Gun type
Item	Model No.
CE marking directive compliance	EMC Directive, RoHS Directive
Charge removal time	0.5 sec. approx. or less (±1,000 V → ±100 V) (Note 2)
Applicable fluid	Air (dried clean air) (Note 3)
Supplied air flow	300 l/min. (ANR) or less
Air pressure range	0.05 to 0.50 MPa
Supply voltage	Accessory AC adapter INPUT: 100-240 V AC ±10 % 50/60 Hz (OUTPUT: 24 V DC)
Power consumption	30 VA or less
Discharge method	High-frequency AC method
Pulse air mode	Pulse 1 (long) / Pulse 2 (short) / CONT (continuous) selectable by switch
LED illumination mode	ON (always ON) / SYNC (synchronized with trigger) / OFF (always OFF)
External input	Ionized air emission operation ON/OFF using OR control with trigger switch Ionized air emission operation ON: Short-circuited to COM (-) Ionized air emission operation OFF: Open
Ambient temperature	0 to +50 °C <b>+32 to +122 °F</b> (No dew condensation allowed), AC adapter: 0 to +40 °C <b>+32 to +104 °F</b>
Ambient humidity	35 to 65 % RH (No dew condensation allowed)
Weight	270 g approx. (main unit only)
Accessories	AC adapter: 1pc. Exclusive intermediate cable (oil-resistant, heat-resistant, bending-resistant type) length 2 m <b>6.562 ft</b> : 1 pc. Straight joints • Tube outer diameter ø8-ø8 mm <b>ø0.315-ø0.315 in</b> compatible type: 1 pc. (Note 4) • Tube outer diameter ø8-ø6 mm <b>ø0.315-ø0.236 in</b> compatible type: 1 pc. • Connector connection terminal (Manufactured by Molex): 3 pcs.

Notes: 1) Where measurement conditions have not been specified precisely, the conditions used were an ambient temperature of +20 °C **+68 °F**.  
2) Typical value for pulse air mode: CONT at 100 mm **3.937 in** from the front of discharge nozzle at an applied air pressure of 0.50 MPa.  
3) Dried clean air is the air passing through air dryer (dew point -20 °C **-4 °F** approx.) and air filter (mesh size 0.01 µm **0.0004 mil** approx.).  
4) At the time of shipment from the factory, ø8-ø8 mm **ø0.315-ø0.315 in** type is attached.

## PRECAUTIONS FOR PROPER USE

- This product includes precision components, so do not drop it or hit it against other objects. If this is not observed, accidents or problems with operation may occur.
- Never use this product in a device for personnel protection.
- Do not use this product in places where there may be danger of flammable or combustible items being present.
- High voltages are applied to the discharge needle, so never touch the discharge needle while the power for the product is turned on, otherwise electric shocks may result.
- Since the tip of the discharge needle is sharp, take sufficient care in handling the discharge needle, or injuries may result.
- If this product is used in an airtight room, ozone emitted from this product may be detrimental. Therefore, in order for this product to be used in an airtight room, be sure to keep the room ventilated.
- Do not direct ionized air toward the face. Ozone may cause irritation to places such as the nose and throat.
- Do not look directly into the white LED spotlight. It may cause injury to the eyes.



## OPTIONS

Designation	Model No.	Description
Discharge needle	<b>EC-GANT</b>	For replacement (1 pc.)
Solenoid valve	<b>EC-GAV</b>	For replacement (1 pc.)

## DIMENSIONS (Unit: mm in)

The CAD data can be downloaded from our website.

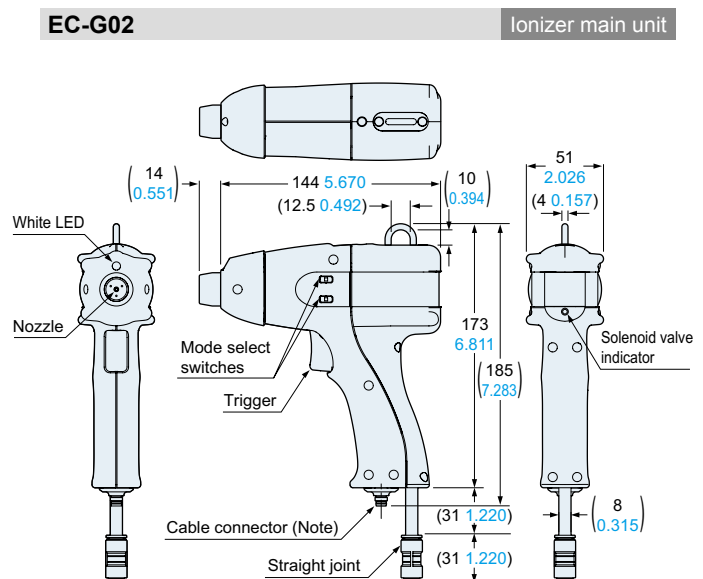

Note: An exclusive intermediate cable (oil-resistant, heat-resistant, bending-resistant type, ø3.7 mm **ø0.146 in**, 2 m **6.562 ft** long) is attached.

## Disclaimer

The applications described in the catalog are all intended for examples only. The purchase of our products described in the catalog shall not be regarded as granting of a license to use our products in the described applications. We do NOT warrant that we have obtained some intellectual properties, such as patent rights, with respect to such applications, or that the described applications may not infringe any intellectual property rights, such as patent rights, of a third party.

**Panasonic**  
INDUSTRY

**Panasonic Industry Co., Ltd.**

Industrial Device Business Division

7-1-1, Morofuku, Daito-shi, Osaka 574-0044, Japan

[industrial.panasonic.com/ac/e/](http://industrial.panasonic.com/ac/e/)