

High-frequency AC Method

Bench Top Ionizer Cleaning Box

EC-B SERIES



EC-B SERIES



Compact dust collection and removal features

Three discharge modes

The **EC-B** features two pulse air modes in addition to the standard continuous mode.

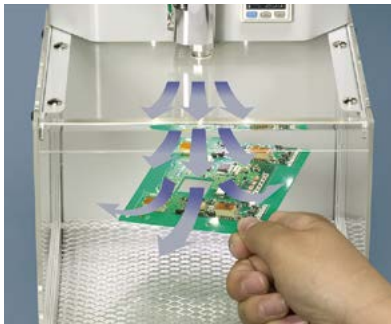

White LED illumination

Three white LEDs illuminate the work area, increasing visibility and helping ensure you don't overlook any dust that has adhered to workpieces.



Dust collecting fan

A powerful dust collecting fan exhausts dust quickly, preventing re-adhesion of dust.

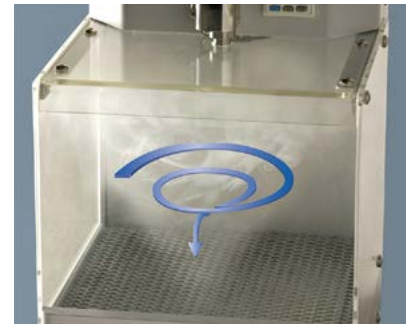

Economic and ecological benefits of pulse (intermittent) air

Electrical charge comparison

Continuous operation

100 %

Pulse 1

55 %

Pulse 2

15 %

CO₂ emissions comparison (per month)

Continuous operation

86 kg

Pulse 1

47 kg

Pulse 2

13 kg

- Dust removal and charge removal by intermittent air
- Possible to control dust removal time in timer mode
- External input allows the tool to be used in conjunction with other equipment such as a foot switch

Note: Calculated using operating conditions at our company Plant, 8 hours per day × 20 days.

ORDER GUIDE

Type	Charge removal time ($\pm 1,000\text{ V} \rightarrow \pm 100\text{ V}$)	Ion balance	Model No.
200 mm 7.874 in width type	0.5 sec. approx or less (Note)	$\pm 10\text{ V}$ or less	EC-B01-EX
400 mm 15.748 in width type			EC-B02-EX

Note: Typical value at 100 mm **3.937 in** from the front of air outlet at an applied air pressure of 0.50 MPa.

OPTIONS

Type	Model No.	Description	
Duct flange	EC-BD50	For $\varnothing 50\text{ mm}$ 1.969 in duct flange	A flange that connects a duct hose for air exhaust to the EC-B main body
	EC-BD76	For $\varnothing 76\text{ mm}$ 2.992 in duct flange	
Air filter	EC-BFX3	For EC-B01-EX	Replacement filter (3 pcs. per set)
	EC-B2FX3	For EC-B02-EX	
Spot nozzle	EC-BAS	Exclusive nozzle for EC-B02-EX	Ionized air can be collected around the center. (2 pcs. per set)

SPECIFICATIONS

Type	200 mm 7.874 in width type	400 mm 15.748 in width type
Item	Model No.	Model No.
	EC-B01-EX	EC-B02-EX
CE marking directive compliance	EMC Directive, RoHS Directive	
Charge removal time ($\pm 1,000\text{ V} \rightarrow \pm 100\text{ V}$)	0.5 sec. approx. or less (Note 2)	
Ion balance	$\pm 10\text{ V}$ or less	
Applicable fluid	Air (dried clean air)	
Supplied air flow	Max. 300 $\text{l}/\text{min.}$ (ANR) or less	Max. 500 $\text{l}/\text{min.}$ (ANR) or less
Air pressure range	0.05 to 0.50 MPa	
Power supply voltage	Accessory AC adapter (Note 3) INPUT: 100-240 V AC $\pm 10\%$ 50/60 Hz (OUTPUT: 24 V DC)	
Power consumption	80 VA or less	90 VA or less
Dust removal operation output	Photocoupler output / Universal • Max sink current: 100 mA • Residual voltage: 2.5 V or less (at sink current of 100 mA or less)	
Output operation	During dust removal operation: ON, during standby: OFF	
External input	0 V short-circuit: Input received	
Timer mode	2 sec. / 5 sec. / 10 sec. / synchronized with sensor or with external input selectable by switch	
Pulse air mode	Pulse 1 (long) / Pulse 2 (short) / OFF (continuous) selectable by switch	
Ambient temperature	0 to $+40\text{ }^\circ\text{C}$ +32 to +104 $^\circ\text{F}$	
Ambient humidity	35 % to 65 % RH (No dew condensation)	
Enclosure earthing method	C (capacitor) earth	
Net weight	Main body: 6.5 kg approx.	Main body: 13 kg approx.
Accessories	AC adapter: 1pc., Filter: 1pc., Protective mesh: 1pc.	

Notes: 1) Where measurement conditions have not been specified precisely, the conditions used were an ambient temperature of $+20\text{ }^\circ\text{C}$ **+68** $^\circ\text{F}$.

2) Typical value at 100 mm **3.937 in** from the front of air outlet at an applied air pressure of 0.50 MPa.

3) Please prepare an AC cable separately as it is needed. The following cables are available as optionals: **CN-ACCN-C2**: AC cable (conforming to CCC), **CN-ACKR-C2**: AC cable (conforming to KTL)

I/O CIRCUIT DIAGRAMS

I/O circuit diagram

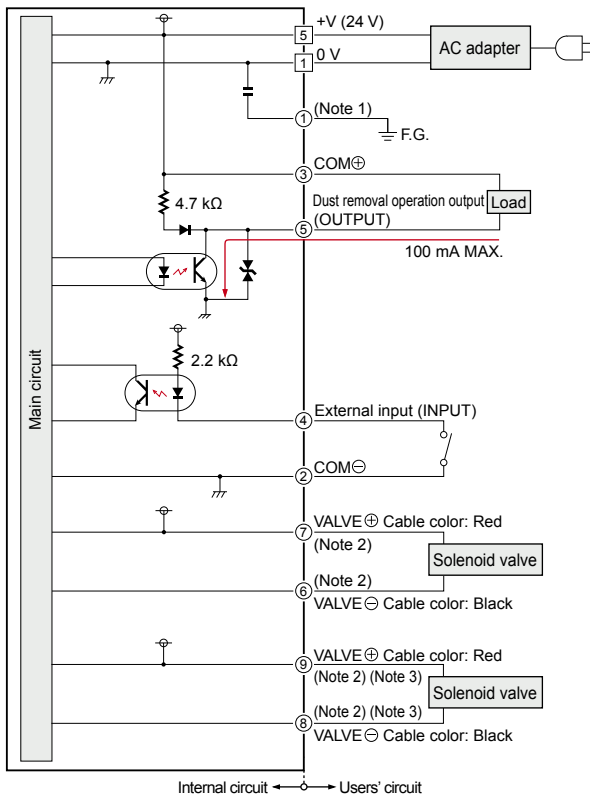

- Notes: 1) The F.G. terminal has continuity with the enclosure.
 2) This terminal is for the solenoid valve only. Do not connect any line to it other than the power supply line for the solenoid valve.
 3) The **EC-B01-EX** has 7 terminals, and the **EC-B02-EX** has 9 terminals.

Terminal block diagram

EC-B01-EX

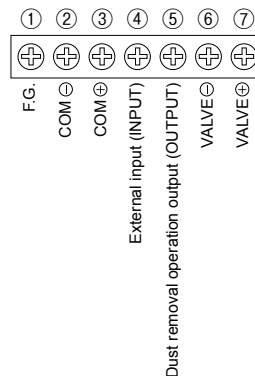

EC-B02-EX

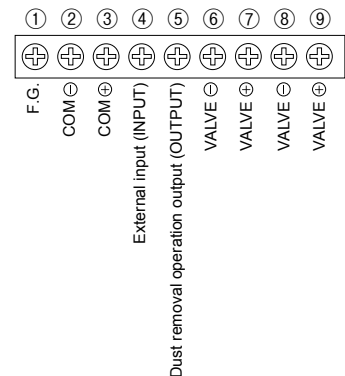

Pin layout for AC adapter power supply connector

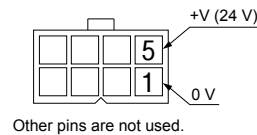

PRECAUTIONS FOR PROPER USE



- Never use this product in a device for personnel protection.
- In case of using devices for personnel protection, use products which meet laws or standards, such as OSHA, ANSI or IEC etc., for personnel protection applicable in each region or country.
- Do not use this product in places where there may be a danger of flammable or combustible items being present.
- When carrying, hold the bottom of the main unit from both sides. Do not hold the transparent antistatic cover or damage may occur.
- High voltages are applied to the discharge needle, so never touch the discharge needle while the power for the product is turned on, otherwise electric shocks may result.
- Be sure to ground the main body of this product via ground terminal to ensure electric shock prevention and reliable charge removal.
- Since the tip of the discharge needle is pointed, take sufficient care in handling the discharge needle, or injuries may result.
- The cut edges of the protective mesh are sharp, so be very careful when handling the mesh, otherwise injury may occur.
- Turn off the power and air before carrying out any maintenance or cleaning.
 Make sure that the supply of air has been fully shut off and that all pressures at the product and inside the tubes are at zero before continuing. If this is not done, air pressure may cause operating problems or accidents.

- This product detects the air supply status.
- If air is not being supplied to the product, or if the pressure of air being supplied is 0.6 MPa or higher, the product will treat this as an error condition, and dust removal operation will not be carried out when an object (electrostatically-charged object) is inserted.
- Do not change the pressure sensor settings. If the settings are changed, this product may cease to operate correctly.

DIMENSIONS (Unit: mm in)

The CAD data can be downloaded from our website.

EC-B01-EX Cleaning box

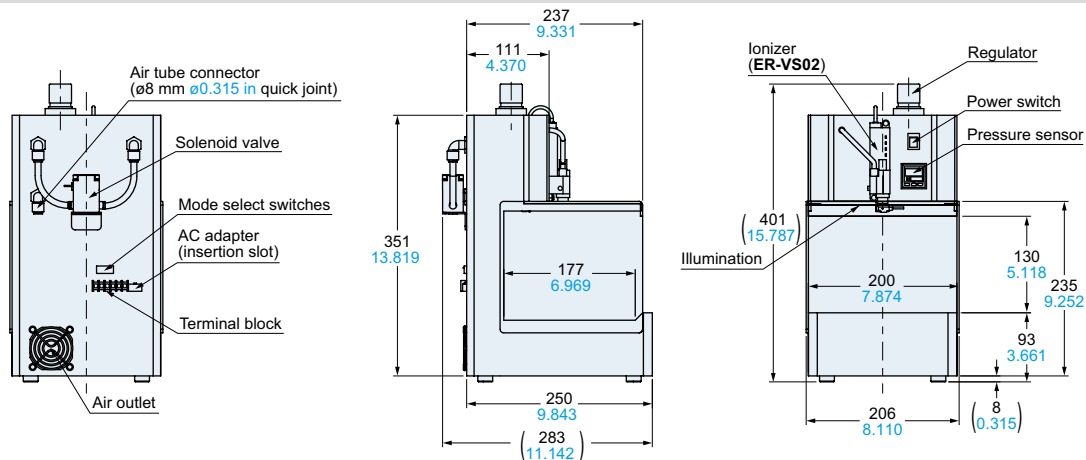

EC-B02-EX Cleaning box

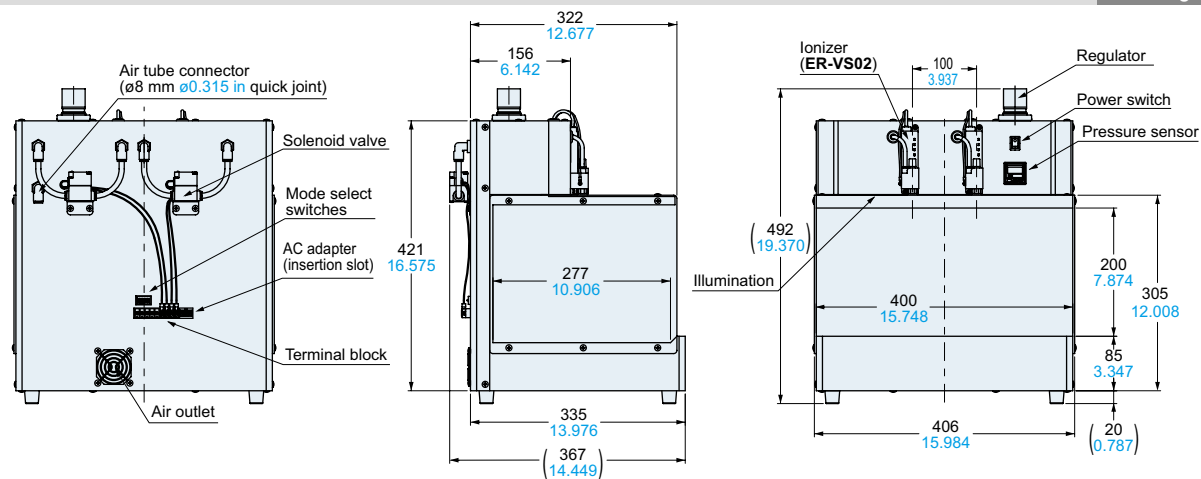

Disclaimer

The applications described in the catalog are all intended for examples only. The purchase of our products described in the catalog shall not be regarded as granting of a license to use our products in the described applications. We do NOT warrant that we have obtained some intellectual properties, such as patent rights, with respect to such applications, or that the described applications may not infringe any intellectual property rights, such as patent rights, of a third party.

Panasonic
INDUSTRY

Panasonic Industry Co., Ltd.

Industrial Device Business Division

7-1-1, Morofuku, Daito-shi, Osaka 574-0044, Japan

industrial.panasonic.com/ac/e/