

Type4 PLe SIL3

Compact & Robust

## Safety Light Curtain

SF4D SERIES



Conforming to  
OSHA / ANSI

GB

Conforming to GB/T 4584 (excluding SF4D-a-01)



JIS

### Experience the Ease of Use!

Slim & Robust Unit Body, New High Power Optical System, Functional Design

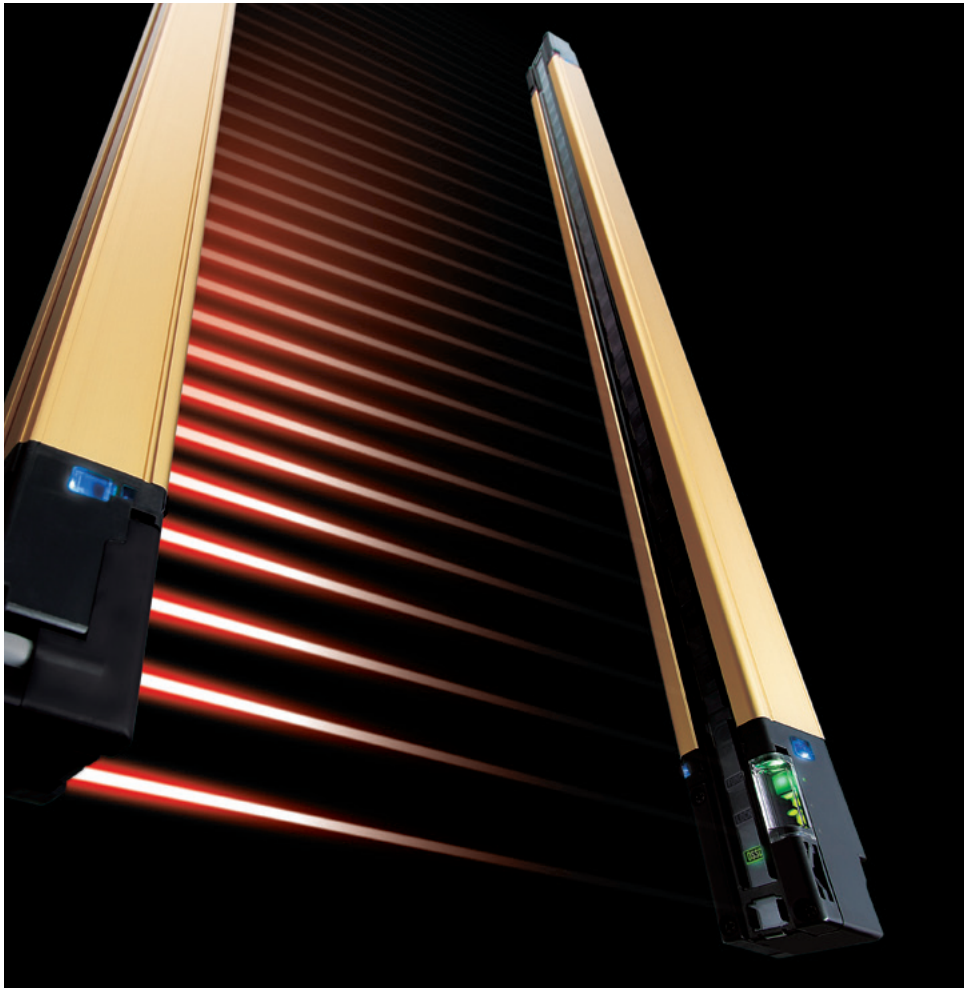

# Slim & Robust Unit Body

## Combined with New Optical System

Experience the ease of use achieved by reflecting the opinions of people involved in installation design, installation, operation and maintenance

**Compact** **Robust** **Safety Light Curtain**

### Introducing the

# SF4D

## Series

Perfect  
fit to

**30 mm × 30 mm**

**1.181 in × 1.181 in**

aluminum frame

\* When installed on back side

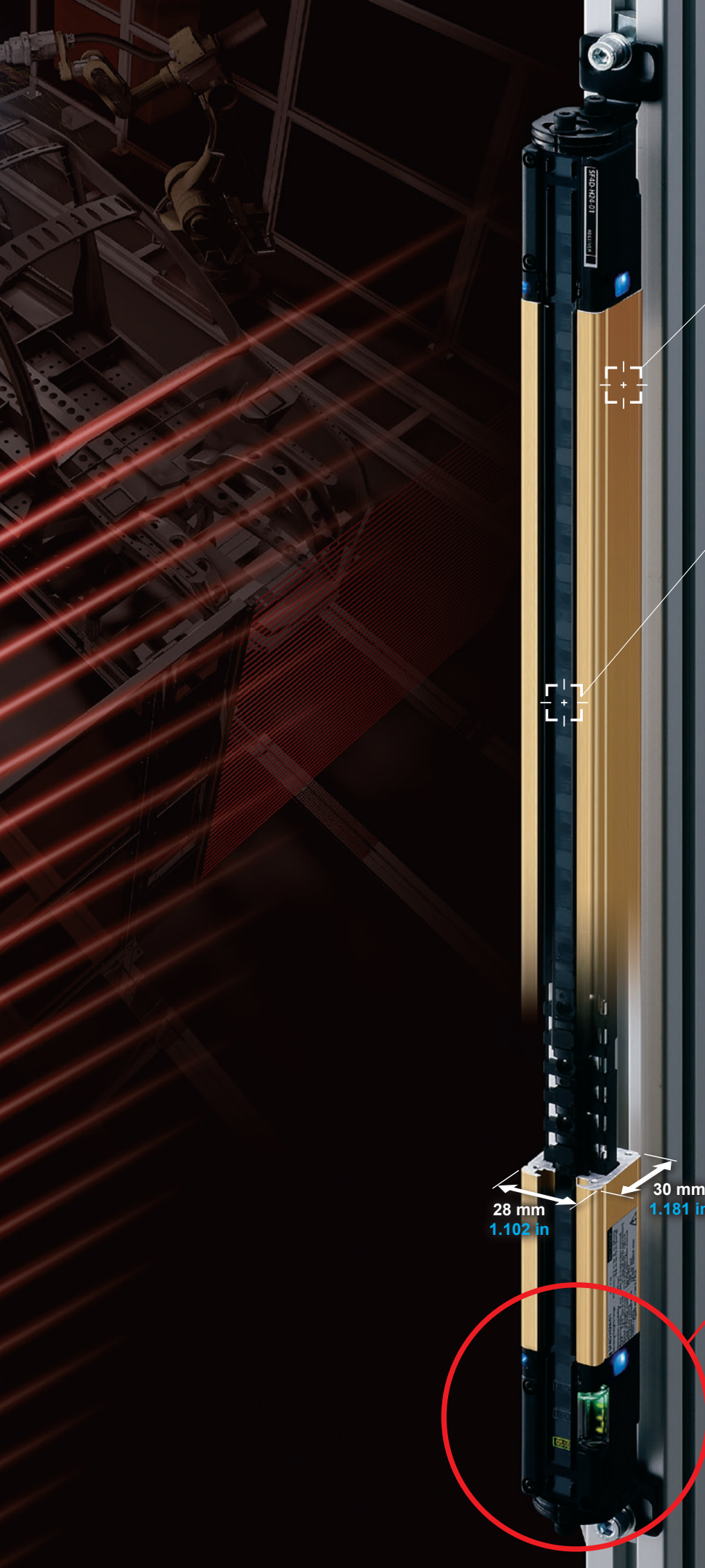

## Slim & Robust

Robust unit body for reliable operation even under harsh conditions

## New Optical System

Ample power and easy beam adjustment

## Evolved Performance and Functional Design

**Experience the Ease of Use!**

# Slim & Robust Unit Body + New High Power Optical System = Stable Operation Even under Harsh Environment

The **SF4D** series features a slim and robust unit body and new high power optical system. The tough unit body prevents entry of liquids and dust. The new series ensures stable and reliable operation of safety light curtain even under an inhospitable environment.

## Slim and robust unit body resists twisting, warping and impact

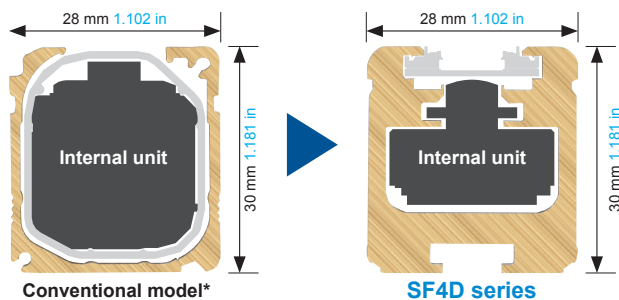

### Downsized internal unit, increased case thickness

The internal unit was redesigned and downsized extensively. The internal unit was downsized to less than 40% (volume ratio) as compared to the conventional model while achieving higher performance. The case structure was also optimized and offers high rigidity without any change in external dimensions. The **SF4D** series provides high performance and high reliability while maintaining the installation and wiring compatibility with the previous models.

\*SF4B series Ver. 2 (excluding robust type SF4B-□G□ <V2>)

### Resists twisting and bending!

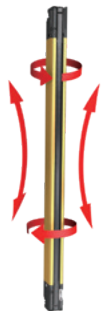

### Resists shock!



Perfect fit to 30 mm × 30 mm 1.181 in × 1.181 in aluminum frame  
\* When installed on back side

■ Unit size (width × depth)

28 mm × 30 mm  
1.102 in × 1.181 in

■ Width of detection surface

8.1 mm  
0.319 in

Narrower sensing surface for improved protection against collisions

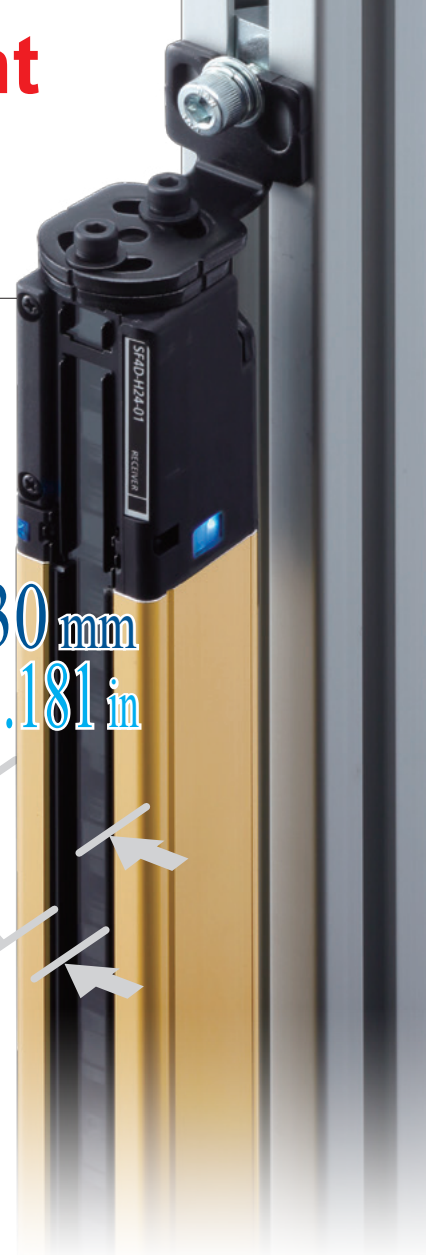

## Mounting brackets feature both rigidity and ease of handling

Completely new mounting brackets and structure. In addition to strengthening the rigidity of the mounting brackets, we have also improved the method of attachment to the safety light curtain unit to significantly increase the mount strength. The dead zoneless mounting bracket and the optional mounting bracket\* that does not extend from aluminum frame are also available for easier use.

\*in case of rear mounting



Beam adjustment mounting bracket

M5 × 2 tightening type: **MS-SFD-1-5**  
M6 × 1 tightening type: **MS-SFD-1-6**  
M8 × 1 tightening type: **MS-SFD-1-8**



Dead zoneless mounting bracket  
**MS-SFD-3-6**



SF4B-G compatible mounting bracket  
**MS-SFD-4BG**

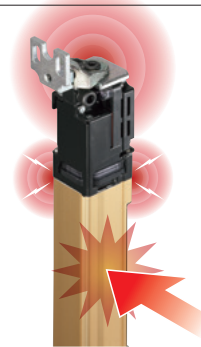

Conventional model

Mounting brackets are attached to the top case and bottom case. When the unit was subjected to intense shock, a large load was occasionally placed on the aluminum case joint.



SF4D series

The mounting brackets is attached to the back of the rigid aluminum case. This reduces the load on the top case and bottom case, and helps prevent beam misalignment and failure due to shock.

## New high power optical system offering stable operation even for long distance setup

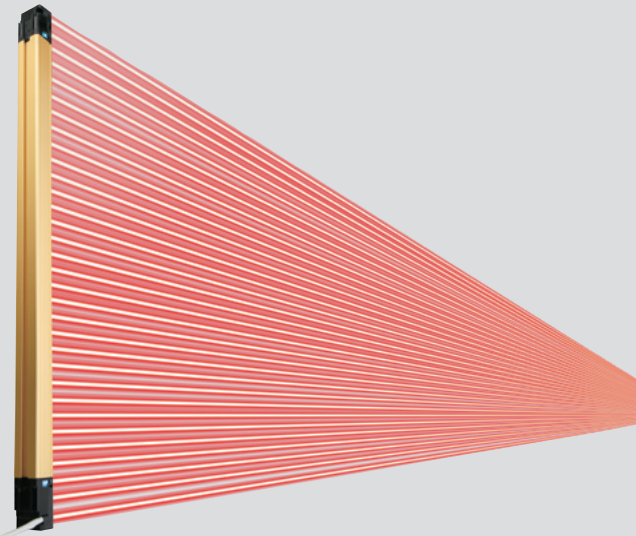

### Increased power of emitter element

The power of the emitter has been increased significantly. The high resistance to dust and dirt contributes to the reduction of maintenance frequency.

#### Operating range

##### ■Short mode (factory setting)

- Finger protection type

0.2 to 7 m

0.656 to 22.966 ft

- Hand protection type

- Arm / Foot protection type

0.2 to 9 m

0.656 to 29.528 ft

##### ■Long mode

- Finger protection type

0.8 to 12 m

2.625 to 39.370 ft

- Hand protection type

- Arm / Foot protection type

0.8 to 15 m

2.625 to 49.213 ft



### Minimization of deviations among elements

We incorporated the element alignment technology that we cultivated for fiber sensors in the safety light curtain. This minimizes curves due to emitter and receiver mounting deviations and quality deviations due to differences in individual elements.

### Redesigned emitter element layout and structure

The scattering light energy from each emitter element is guided efficiently through the lens. The light energy of the emitter element is utilized fully, and the light distribution characteristics were optimized for the specific aperture angle.

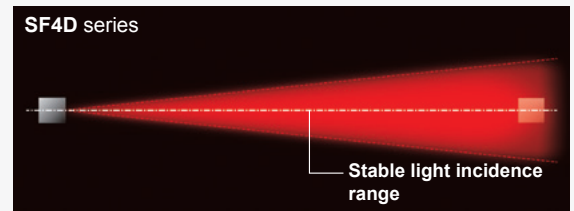

\* The aperture angle of a Type 4 safety light curtain is specified as a maximum of 2.5° each on the right and left at a detection distance of 3 m 9.843 ft or more.

#### Other benefits

"Slim & robust unit body" and "new high power optical system"

**mean easy alignment of beam axes even over a long distance.**

The SF4D series offers improved resistance to twisting and warping to enable easier adjustment of beam axes over a long distance. Combined with the new high power optical system featuring the redesigned emitter element, light distribution characteristics and layout, the new series has realized the ease of beam axis adjustment.

Furthermore, the SF4D series is equipped with an application indicator to further facilitate beam axis adjustment as well as a digital indicator with a numeric display of light incidence margin, thus helping reduce the time required for beam axis adjustment.

## Shuts out liquids and dust

IP67, IP65 (IEC)

NEMA Type 13 (NEMA 250)

The SF4D series complies with IP67 and IP65 (IEC) as well as NEMA Type 13 (NEMA 250)<sup>\*1</sup>.

The unit structure prevents the entry of not only water but also coolant and other liquids<sup>\*2</sup> to protect the internal unit.

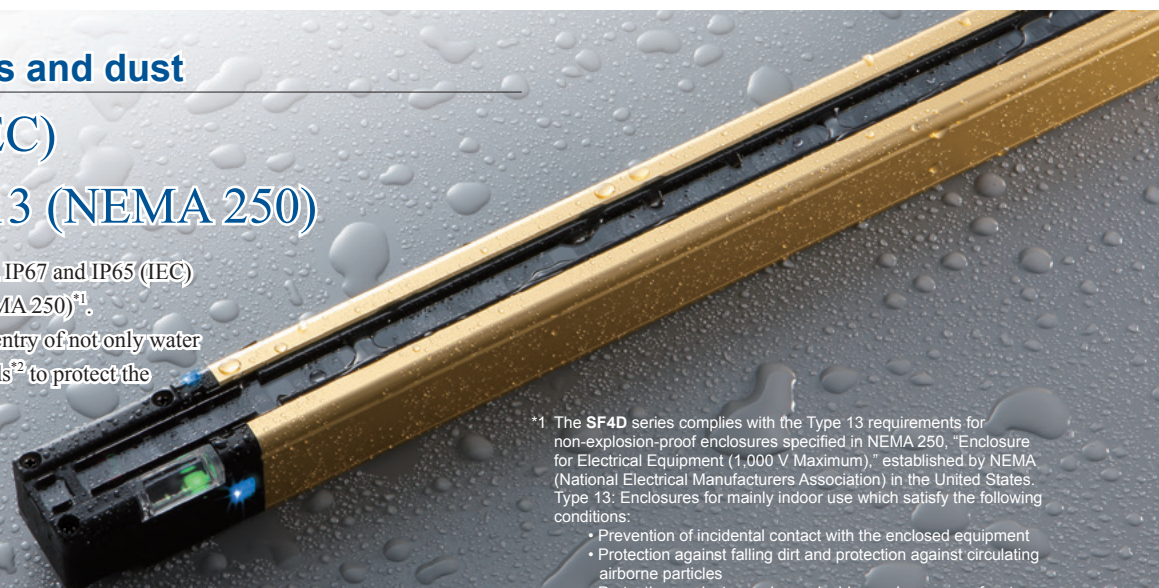

\*1 The SF4D series complies with the Type 13 requirements for non-explosion-proof enclosures specified in NEMA 250, "Enclosure for Electrical Equipment (1,000 V Maximum)," established by NEMA (National Electrical Manufacturers Association) in the United States. Type 13: Enclosures for mainly indoor use which satisfy the following conditions:

- Prevention of incidental contact with the enclosed equipment
- Protection against falling dirt and protection against circulating airborne particles
- Protection against spraying, splashing and seepage of water and noncorrosive lubricants

\*2 If used in a place where cutting fluid can splash, additives in the fluid may cause degradation. Please check in advance whether the SF4D series is resistant to the specific cutting fluid used by your company.

# Experience the Ease of Installation, Construction and Maintenance!

## Multifunctional indicators for an at-a-glance understanding of the status of safety light curtain

### Digital indicator with a numeric display of light incidence margin facilitates beam axis adjustment and preventive maintenance.

The light incidence margin is indicated by the “stable light incidence indicator” and “digital indicator”. This function enables appropriate beam adjustment and work quality control during installation of the device. The indicators also show whether there is dirt on the detection surface or beam axis misalignment due to play. This enables the numeric display to be used for startup inspection and preventative maintenance.

\* When optical synchronization is set, only the indicator on the receiver lights up.



#### Stable light incidence indicator

- Stable light incidence: Lights green
- Unstable light incidence: Lights orange
- Light blocked: Off

#### Digital indicator

- Incident light level 3: Lights green “3”
- Incident light level 2: Lights green “2”
- Incident light level 1: Lights green “1”
- Light blocked: Off

#### Unstable light incidence



#### Stable light incidence

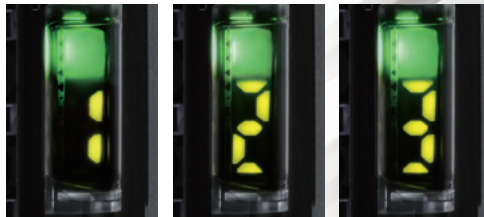

← Low Margin of incident light intensity High →

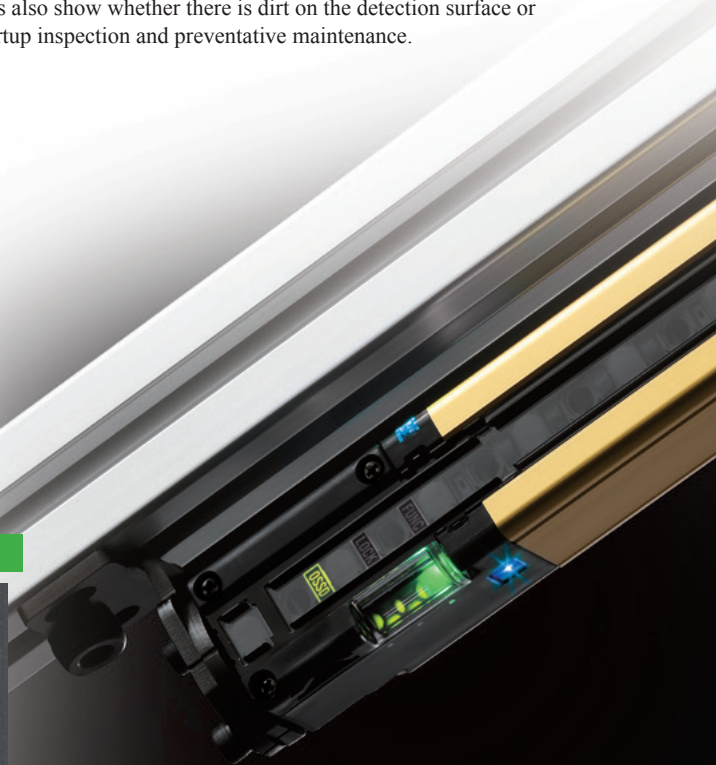

Other features!

### Well-thought-out indicators

The indicators show stable light incidence status and notify various conditions. The OSSD indicator, interlock indicator and function setting indicator are arranged between the beam axes for easy visibility.

Light emission intensity control indicator

Test indicator

Operation indicator

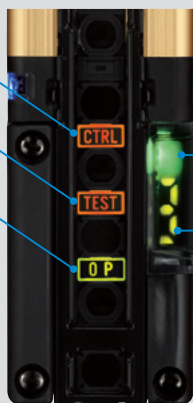

Emitter

Stable light incidence indicator

Digital indicator



Receiver

Function setting indicator

Interlock indicator

OSSD indicator



#### Light incidence intensity indication

The indicator shows the light incidence margin with a numeric display (1 to 3). The displayed number decreases when there is dirt on the detection surface or beam axis misalignment occurs due to a loose mounting condition. This provides useful information during pre-operation inspection and preventive maintenance.

\* Only the indicator on the receiver lights up when optical synchronization is set.



#### Polarity indication

The indicator shows the set polarity when power is turned on. This makes it easy to confirm proper operation after wiring.



#### Error indication

The new series is also equipped with the error indication function, a well-received feature of our previous models. In an environment where a PC cannot be brought in or when a problem occurs at a remote location, the displayed error number lets you identify the cause of problem. This facilitates restoration work.

## Indicator for improved work efficiency

The application indicator improves work efficiency in a variety of ways by providing support to work activities ranging from daily equipment operation to installation and maintenance. The indicator function can be switched between two options.

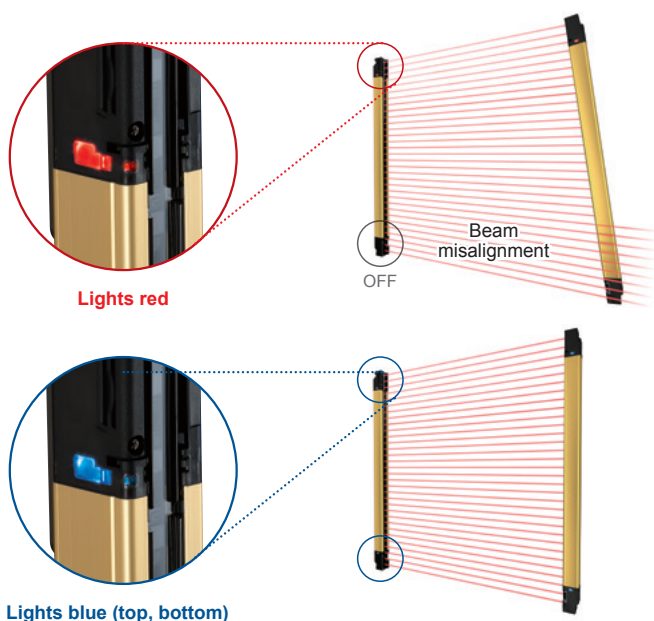

### Beam axis adjustment mode

The color of the indicator notifies whether the beam axes of both top and bottom ends are aligned properly. The indicator is easy to see from any direction so mistakes can be prevented in a long-distance setup.

**When beam axes of both top and bottom ends are aligned properly:**

All application indicators light blue.

**When beam axis of either of top end or bottom end is aligned:**

The indicators of only the aligned side light red.

**When beam axes of both top and bottom ends are misaligned:**

All application indicators are OFF.

\* When optical synchronization is set, only the indicator on the receiver lights up.

Tidbit

### Laser alignment tool enables pre-operation adjustment

The optional laser alignment tool, **SF-LAT-2N**, enables the adjustment of beam axes by emitting a laser spot light.

Since it is powered by batteries, adjustment can be made before power is supplied to the equipment, thus reducing the pre-operation setup time.

### Laser alignment tool

• SF-LAT-2N

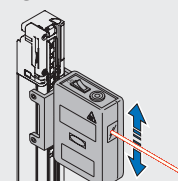

### Application indicator mode

Can light and blink in three colors (green, red, and orange) according to an external input. The indicator can be used to indicate work instructions or equipment status.

\*When optical synchronization is set, only the indicator on the receiver lights up.

\*The DIP switches in the unit must be set to use this function.

For details, see the manual. The manual can be downloaded from our website.



**Green** When indicator input 1 is ON and indicator input 2 is OFF



**Red** When indicator input 1 is OFF and indicator input 2 is ON



**Orange** When both indicator inputs 1 and 2 are ON

## COLUMN

### Stable light incidence indicator that even shows the amount of margin

The stable light incidence indicator is commonly used when installing a new safety light curtain to equipment or when checking if the existing safety light curtain is operating properly. Previously, however, even if the stable light incidence indicator was ON, there was no way of knowing whether there was an ample margin or the condition is close to unstable light incidence.

The **SF4D** series not only shows whether the light incidence is stable or unstable but also the amount of margin with a numeric display. Therefore, it is possible to numerically manage the stability margin of the safety light curtain. When the amount of received beam intensity decreases during equipment operation due to oil mist or other reasons, the digital display shows the stability margin of the safety light curtain. Thus, cleaning can be scheduled and conducted at the most suitable timing.

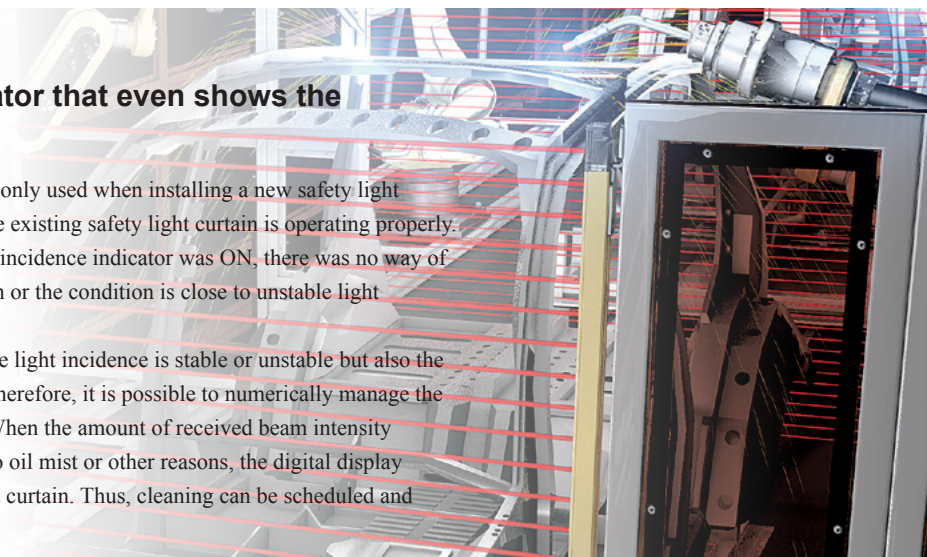

# Experience the Ease of Installation Designing, Installation and Construction!

## Evolved **performance** and **functional design**

We paid careful attention to details during the product design stage, ranging from the calculation of safety distance to installation, wiring and additional installation ease.  
We improved the performance and achieved the functional design so that users can appreciate the "ease of use" in any situations.

### Fast response time 10 ms or less

The OFF response time of the control outputs (OSSD 1, OSSD 2) of the SF4D series is 10 ms or less (when not connected in series or in parallel). [18 ms or less when connected in series or in parallel] The SF4D series contributes to the reduction of equipment size.

Not connected in series / parallel

10 ms or less

Connected in series / parallel

18 ms or less

Regarding the response time by number of beams, see "Control output (OSSD 1, OSSD 2) OFF response times" (p.27).

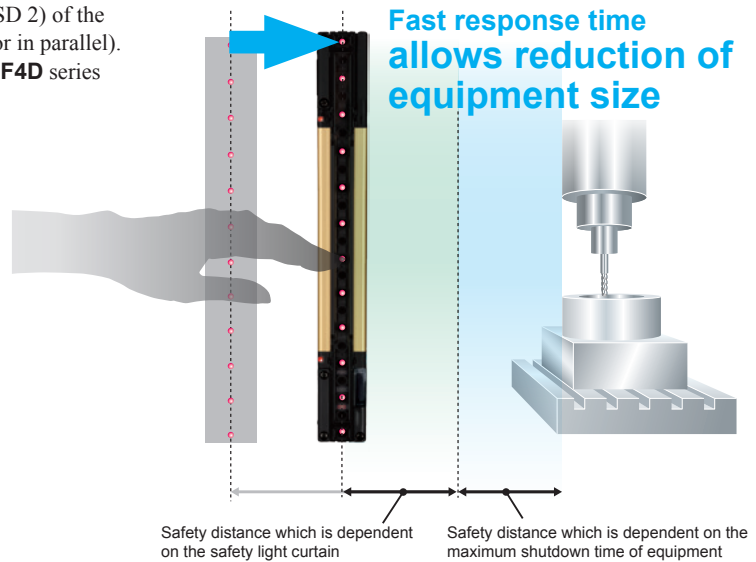

### Dead zoneless design enables easy calculation of safe distance.

Inherits the dead zoneless design of the previous SF4B series. Even in an L-shaped layout or a U-shaped layout, the beam pitch does not change\*, making calculation of the safe distance easier.

\* Excluding the finger protection type SF4D-F□(-01)

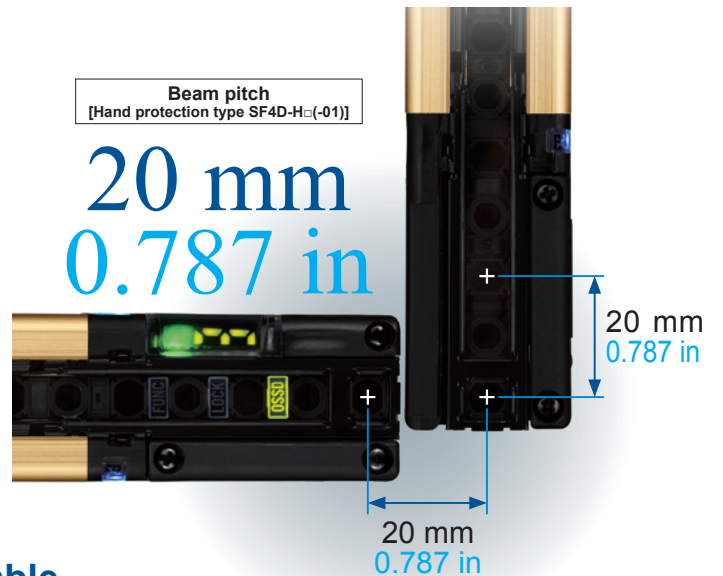
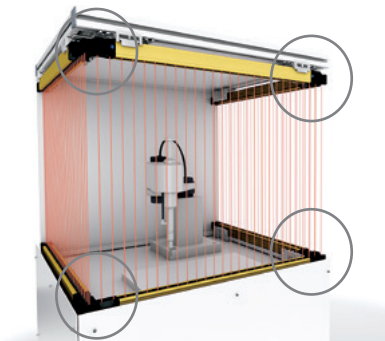

### Easy to attach / detach front access cable



Uses the well-received front access cable of previous models. The cable can be attached and detached after the safety light curtain is installed on the equipment. This allows easy replacement in the event that the cable is damaged.

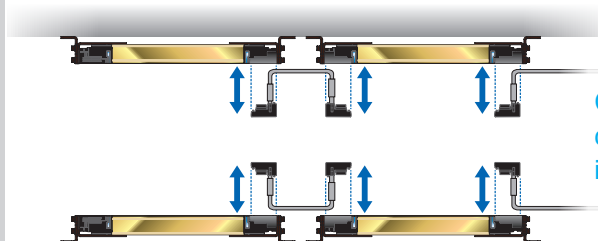

Cables can be connected after installation of units!



## Series connection of up to 5 units

Up to five units (1 main sensor and 4 sub-sensors) can be connected in series, and the maximum number of beams has been increased to 256. This provides extra convenience when installing additional equipment, when increasing the detection width (protection height), and when using one system for protection of multiple locations.

Present (example: 3 units connected in series)

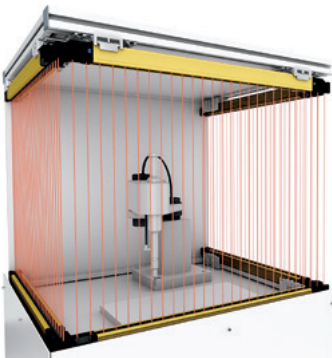

Adapts to additional equipment installation and safety area enlargement.



After equipment addition / safety area enlargement (example: 5 units connected in series)

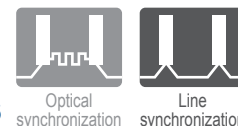
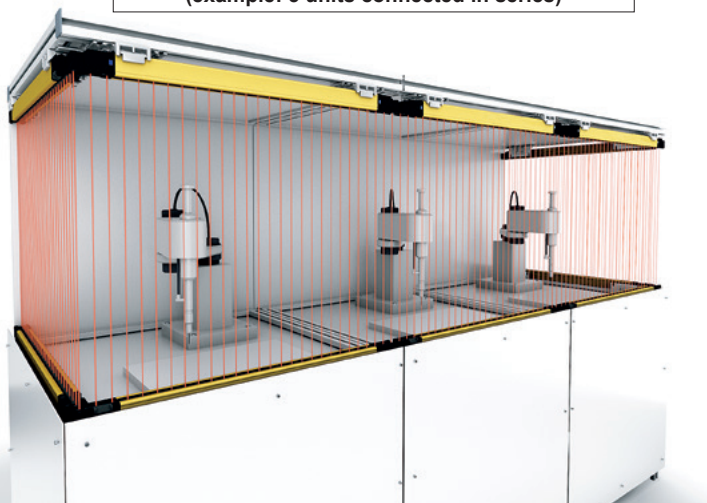

## Selectable synchronization method and cable to suit various applications

When choosing and installing a safety light curtain, the synchronization method and cable can be selected flexibly according to the customer's specific application and needs, such as the basic configuration or safety-enhanced configuration with improved operability.

- : Functional by default
- Software: Functional when setting software is used
- (Software): Functional by default. Function can be expanded when setting software is used

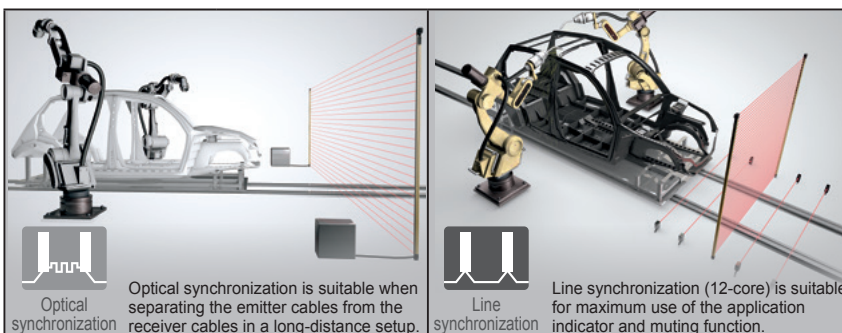

Cable type		5-core	12-core	8-core	12-core
Function	Interlock function		Software	○ (Software)	○ (Software)
	Lockout release function	○	○	○	○
	Test input function	○	○	○	○
	Auxiliary output (non-safety output) function		○ (Software)	○ (Software)	○ (Software)
	External device monitor function		○ (Software)	○ (Software)	○ (Software)
	Muting / Override function		Software		○ (Software)
	Application indicator function	Software	○ (Software)	Software	○ (Software)
	Parallel interference prevention function				Software
	Fix blanking function	Software	Software	Software	Software
Floating blanking function	Software	Software	Software	Software	

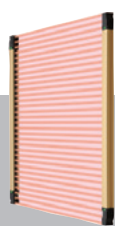

### Y-shaped connector for further reduction of wiring

Y-shaped connector (optional)

When 8-core cables and line synchronization are used, connection of only five cables is required when the Y-shaped connector (optional) is used. This allows easy connection to a safety PLC or other devices, and also helps eliminate wiring mistakes and reduce the man-hours required for wiring.

▶ For details, see p.22.

# Experience the Ease of Setting!

## Simple setup of complex safety control

### Setting software

### Configurator Light Curtain

The handy controller software, which was well-received by users of our previous models, has evolved. The new setting software, **Configurator Light Curtain**, allows visually intuitive operation.

It provides powerful support to maintaining stable operation and troubleshooting by allowing the internal setup of the **SF4D** series product, collection of error history, planning of corrective measures and real-time monitoring of light incidence condition.

#### Main functions

- Operation monitoring function
  - Monitoring of received light intensity / extraneous light of individual beam
  - I/O monitoring
- Error history display
- Light blockage history, unstable light incidence history
- Muting setting function
- Override setting function
- Blanking setting function
  - Fixed blanking setting function
  - Floating blanking setting function
- External device monitoring setting function
- Auxiliary output setting function

\* Note that the usable functions vary depending on the synchronization method (optical synchronization, line synchronization) and the type of cables (5-core, 8-core, 12-core) used. For details, refer to "Selectable synchronization method and cable to suit various applications" (p.9) and the manual. The manual can be downloaded from our website.



Safety light curtain SF4D series

Communication module SF4D-TM1 (optional)

USB2.0 cable (A: Mini-B)  
\* Purchase separately.

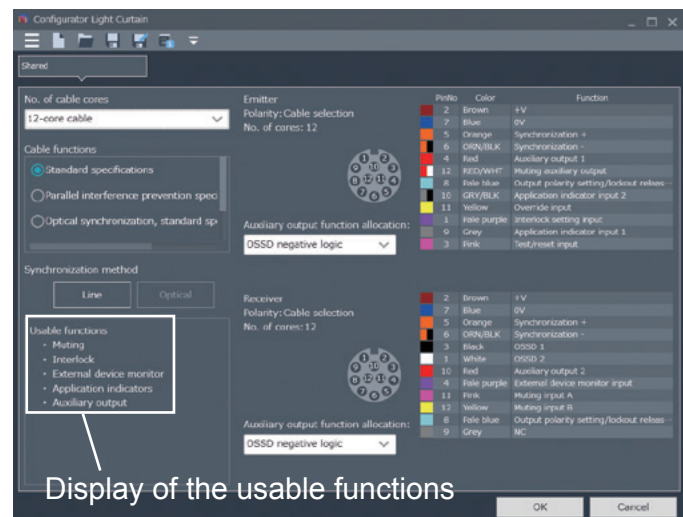
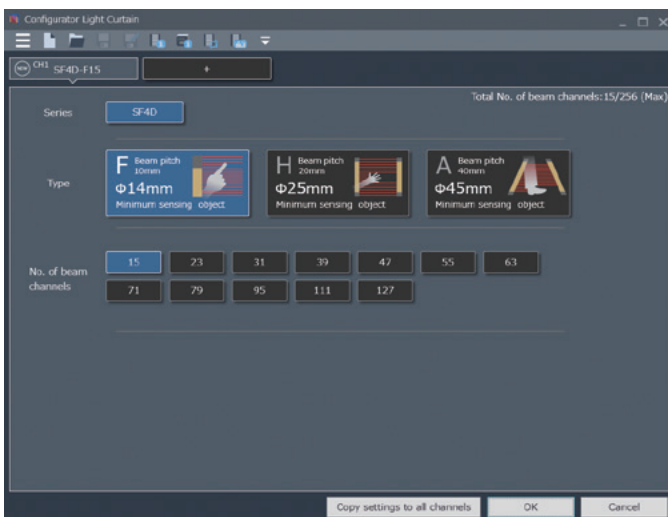

Display of the usable functions

## Operation monitoring function (monitoring of received light intensity / extraneous light of individual beam)

This function displays the light incidence conditions of individual beams in real time. It facilitates the setup work and streamlines the maintenance planning by enabling visual confirmation of changes in the light incidence intensity resulting from dirty detection surface or beam misalignment. In addition, the function can also monitor extraneous incident lights. It helps prevent unexpected malfunction in advance.

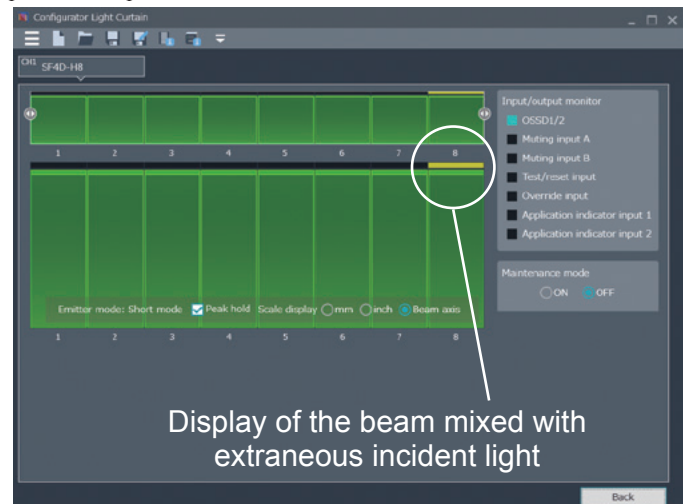
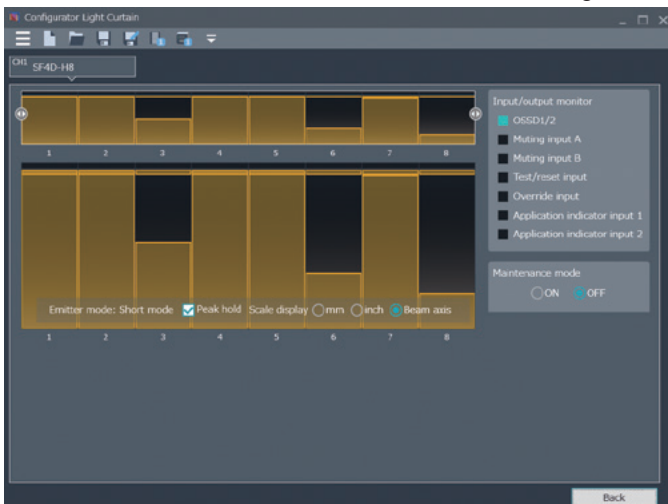

Display of the beam mixed with extraneous incident light

## Muting setting function \*Excluding SF4D-□-01

This function is used to set the arrangement of muting sensors and select the most suitable settings using the application. It is also equipped with a time chart function, which obtains actual input timing to facilitate adjustment work.

Muting sensor arrangement model	Description
Exit-only	This is used when a muting input cannot be set up at the outlet side such as a workpiece discharge section. Since the workpiece passing time can be set in the timer, muting input on the outlet side is not required.
Simultaneous input	This is used when there is no space for acquiring the muting input time difference between two systems. There is no need to provide a time difference for muting inputs. * When the muting sensor output is NO / NC.
Parallel 4-sensor Cross 2-sensor Invalid when rising	The input time difference between the muting inputs of two systems is detected and the muting condition is controlled.

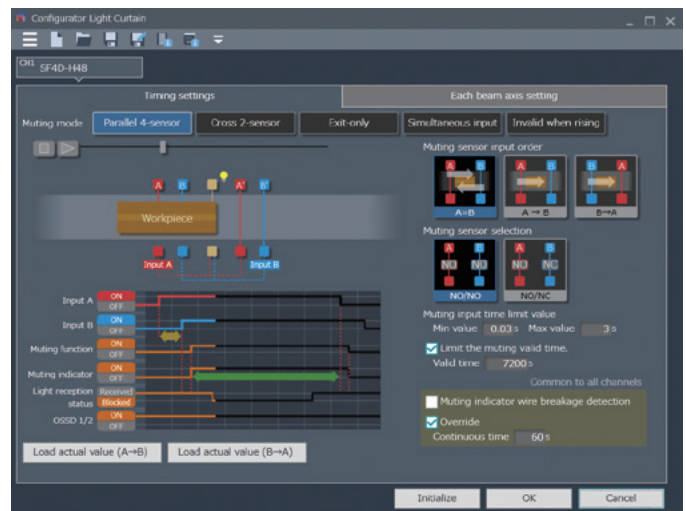

## Blanking setting function \*Excluding SF4D-□-01

The blanking setting function has also advanced. It supports not only manual setting while allowing the user to check the light reception condition in real time and but also batch setting based on teaching. Furthermore, fixed blanking and floating blanking can be set using the same screen. It alleviates the cumbersome setting work.

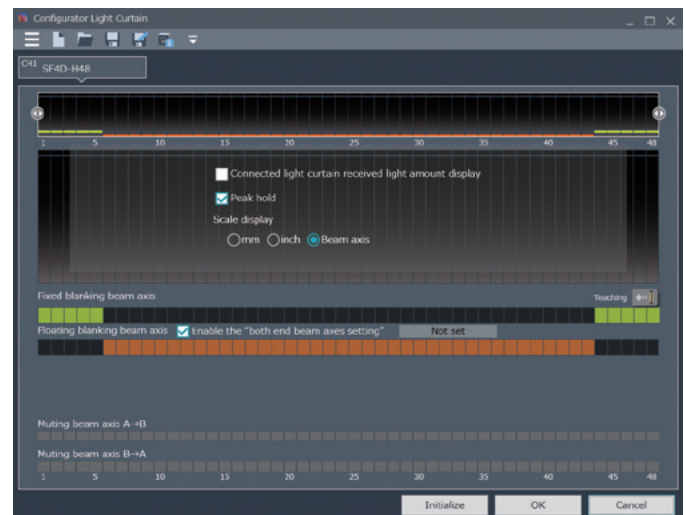
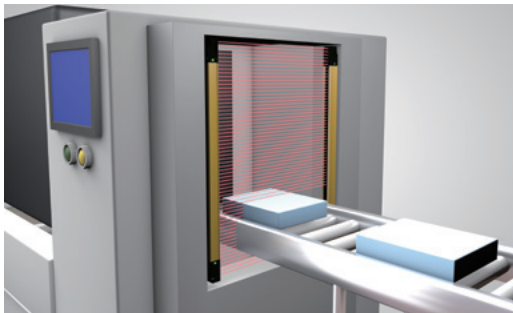

## Communication module copy function \*Excluding SF4D-□-01

When a PC cannot be brought in, the communication module can be used to write the setting data of the safety light curtain and also to read error information.

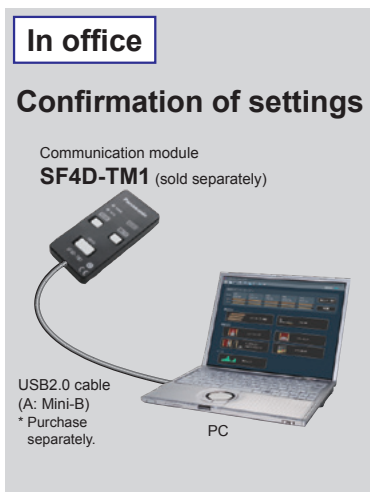

\* USB cable is not supplied with the product.  
USB2.0 cable (A: Mini-B) must be procured by the user.



At installation site

Using only the communication module

**Communication module → SF4D series**  
Use the WRITE button on the communication module to write settings.

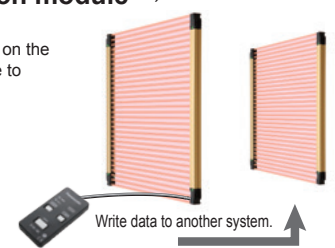

**SF4D series → Communication module**  
Use the READ button to read settings or error information.

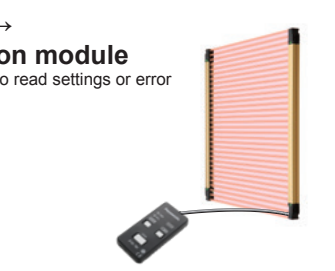

Configuration Light Curtain can be downloaded free from our website.

# IO-Link Communication Unit for "Visualization" of Safety Light Curtains

Easy add-on!

No alteration of safety circuit necessary

IO-Link Communication Unit  
SFD-WL3



\* For SF4D series only  
\* Above photo shows a unit with all indicators turned on.

## Remote monitoring of safety light curtain status

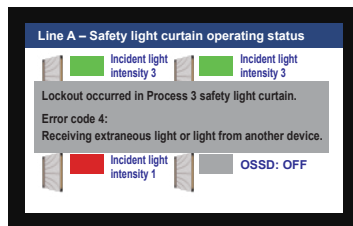

## Storage of setting data, restoration of settings

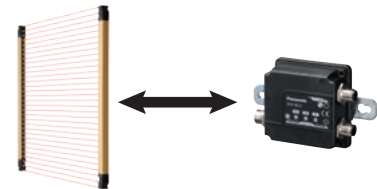

### Confirmation of light intensity margin

Incident light intensity information enables the determination of whether maintenance is necessary or not. This helps prevent shut-down of the line due to light beam deviation or dirty sensor. The information is also useful in conducting remote inspection or the like at the start of work.

### Confirmation of error history

If an error occurs, the source of the error and its detail can be checked remotely, thus facilitating the identification of the problem location and analysis of the cause.

### One-touch setting after replacement

The setting data stored in the communication unit allows one-touch restoration of the settings when the safety light curtain is replaced.

### Example of configuration

Safety output and IO-Link communication are separated from each other so that the safety light curtain can be monitored without any alteration of the safety circuit.

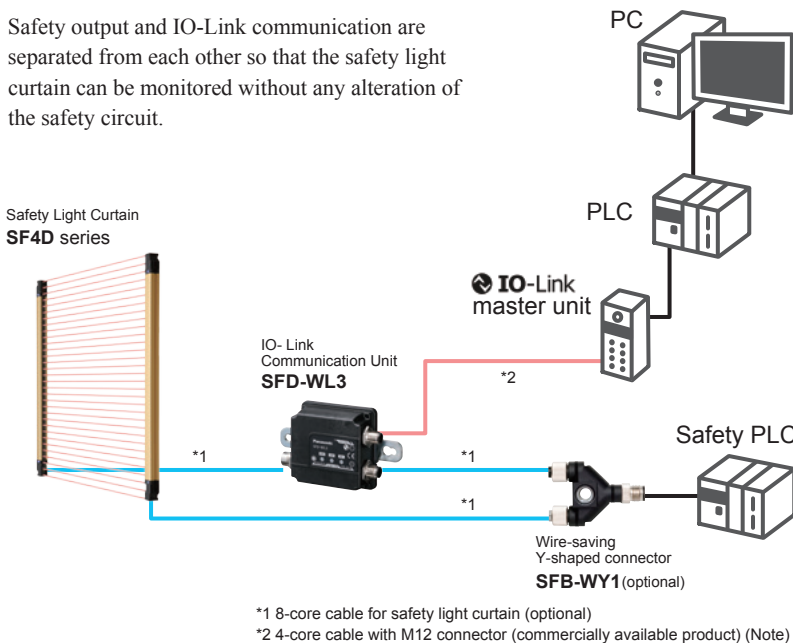

Note: The product and IO-Link master unit must be connected with a cable of 0.3 mm<sup>2</sup> or more. The total length of the cable must not exceed 20 m 65.517 ft.

### Example of IO-Link data output

#### Process data

- Light received / blocked information
- Stable / unstable incident light information
- Extraneous light information
- Emitter / receiver lockout information
- Incident light intensity information (OFF, 1, 2, 3)
- OSSD output information
- Communication control status
- Number of units in series connection

#### Service data

- Safety light curtain main unit information
- SFD-WL3 main unit information
- Incident light intensity information of individual beams (32 levels)
- Error code



Use the safety light curtain monitoring information obtained via IO-Link only for diagnostic purposes. Do not use it for safety control purposes.

# Global Specifications for Easy Use Anywhere in the World

## Global specifications for anywhere use in the world

The SF4D series' global specifications comply with the following standards.



### Supports both PNP and NPN polarities

Every model in the SF4D series supports both PNP transistor output and NPN transistor output. Thus, the SF4D series products adapt to any control circuits used around the world, making it possible to use the product when PNP is installed overseas, when NPN sensors are replaced, when the positive pole is grounded in the factory, when moving equipment to overseas facilities, etc.

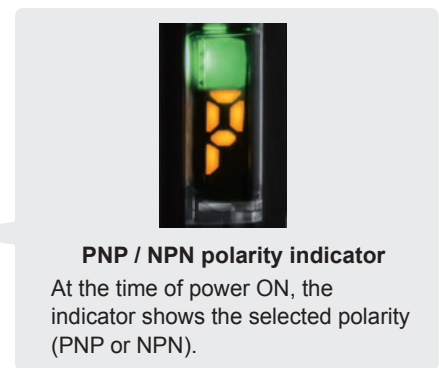
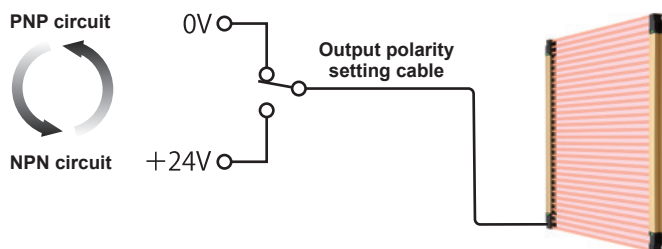

### Easy change of polarity by simple cable connection

Connecting the output polarity setting cable to 0 V results in PNP output.  
Connecting the output polarity setting cable to +24 V results in NPN output.

## Configuration of simple safety circuit by combining a control unit

**SF-C21** **Easy compliance with control category 4 specifications.**  
**Designed for optimum control of SF4D series.**

**Safety control unit**

This safety controller does not require a knowledge of programming. The simple settings only require selection of an internal logic. A free software tool allows intuitive operation. Logic customization, monitoring, and simulation functions are also provided to enable surprisingly easy circuit building.

- Supports up to control category 4
- Supports PNP polarity

**SF-C11**

**Connector connection control unit**

The wiring with the light curtain can be done easily with 8-core cable with connector. It reduces time for installation and replacement.

- Supports up to control category 4
- Supports presses used in Japan (shearing machines not supported)
- Supports both PNP and NPN

**SF-C13**

**Thin control unit**

22.5 mm 0.886 in thinness has been realized. Possible to install in a small space of the board.

- Supports up to control category 4
- Supports presses used in Japan (shearing machines not supported)
- Supports both PNP and NPN

# List of Options for Safety Light Curtain

## Safety light curtain

1 ▶ P.16

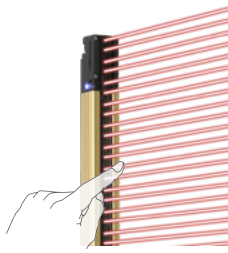

Finger protection type  
Min. sensing object  $\varnothing 14$  mm  $\varnothing 0.551$  in  
(10 mm  $0.394$  in beam pitch)

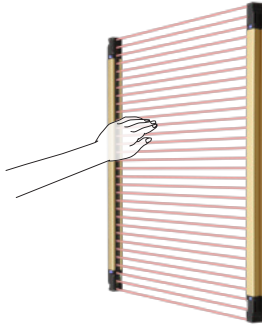

Hand protection type  
Min. sensing object  $\varnothing 25$  mm  $\varnothing 0.984$  in  
(20 mm  $0.787$  in beam pitch)

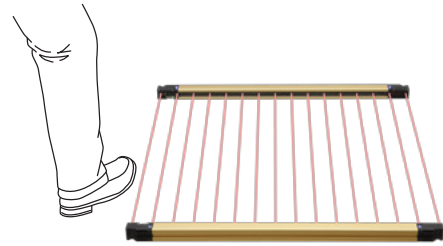

Arm / Foot protection type  
Min. sensing object  $\varnothing 45$  mm  $\varnothing 1.772$  in  
(40 mm  $1.575$  in beam pitch)

## Sold separately

## Mounting bracket

2 ▶ P.17



Beam adjustment mounting bracket



Dead zoneless mounting bracket



SF4B-G compatible mounting bracket

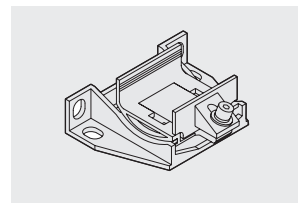

Intermediate supporting bracket

## Sold separately

## Cable / protective tube

3 4 5 6 7 8 9 10 ▶ P.18~

### Bottom cap cable

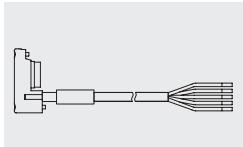

Discrete wire

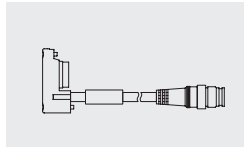

Connector

### Extension cable

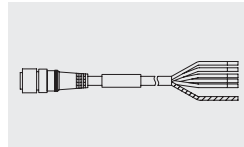

With connector on one end

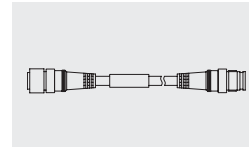

With connectors on both ends

### Cable for series connection

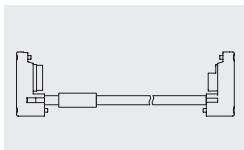

### Protective tube

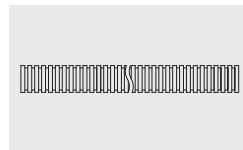

## Sold separately

## Options

▶ P.20~



Communication module



IO-Link communication unit

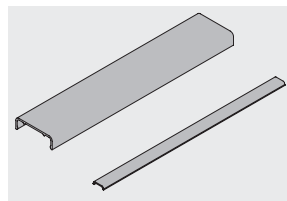

Front protection cover



Corner mirror

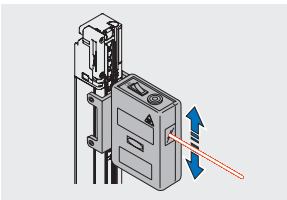

Laser alignment tool



Y-shaped connector

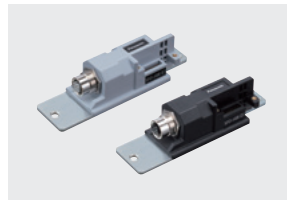

SF4D conversion adapter  
(For replacing SF4B series with SF4D series)



Control unit

# PRODUCT CONFIGURATION



Mounting bracket, mating cable and protective tube are sold separately.

## Standard components (5-core cable)

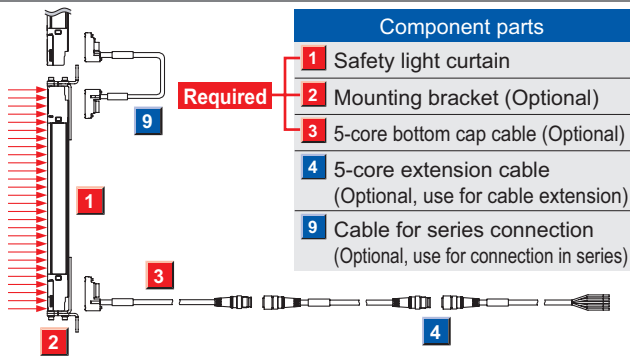

## Standard components (8-core cable)

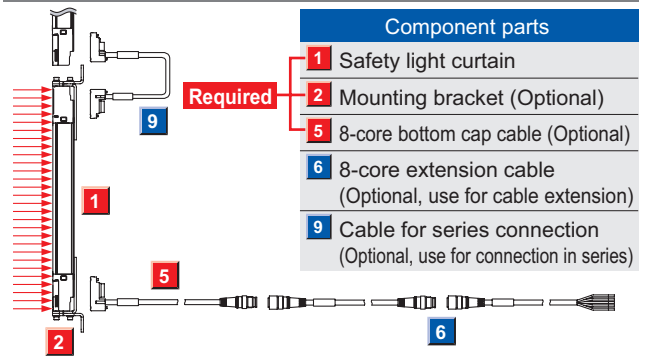

## Muting control components (12-core cable)

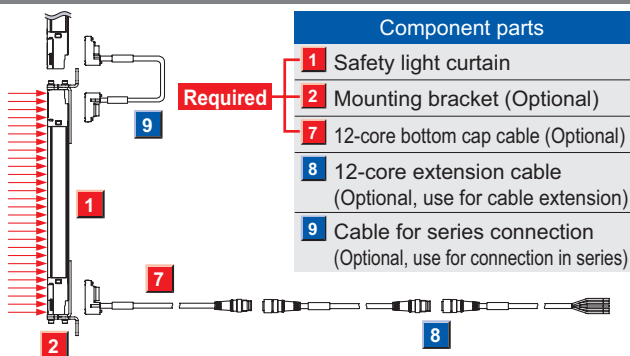

Using SF4D-□-01 as a safety device for a press or shearing machine (paper cutting machine) in Japan (See the above when using SF4D-□-01 as a safety device for other types of machine)

## Standard components (5-core cable)

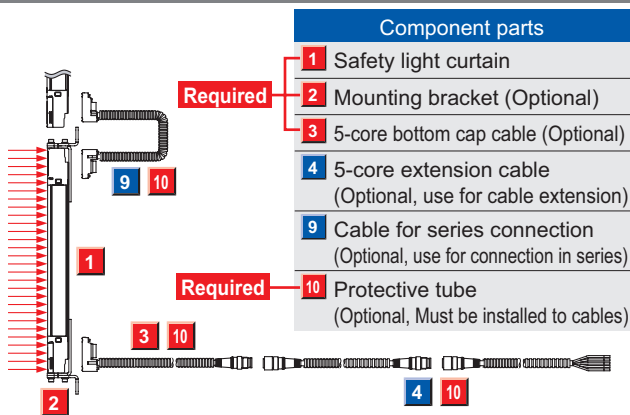

## Standard components (8-core cable)

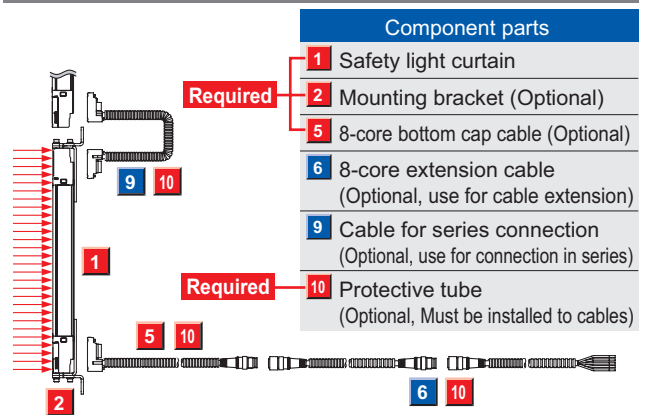

## Muting control components (12-core cable)

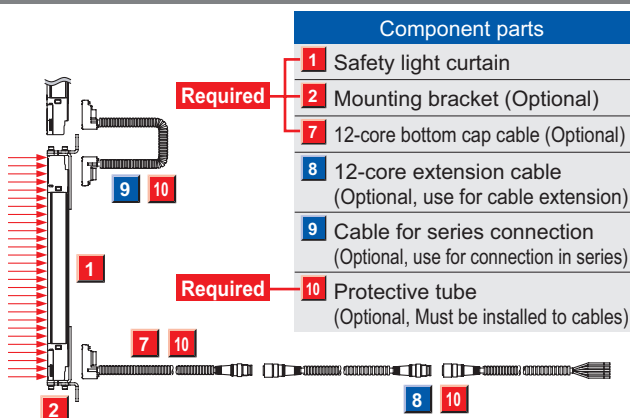

When using SF4D-□-01 as a safety device for a press machine or paper shearing machine in Japan, always attach the protective tube SFPD-A10 (tube length: 10 m 32.808 ft) (optional) to the cable.

# ORDER GUIDE

## 1 Safety Light Curtain

Mounting bracket and bottom cap cable are not supplied with the safety light curtain. Be sure to order them separately.

Type	Model No.	Japanese press machine or paper shearing machine compliant	Operating range (Note 1)	Number of beam channels	Protective height (Note 2)	When using as safety equipment for Chinese press machine or when using SF4D-□-01 for Japanese press machine or paper shearing machine	Beam pitch	Both end beam axes position
					A		B	C
Finger protection type Min. sensing object $\phi 14$ mm $\phi 0.551$ in (10 mm $0.394$ in beam pitch)	SF4D-F15	SF4D-F15-01	0.2 to 7 m 0.656 to 22.966 ft (Short mode)	15	150 mm 5.906 in	140 mm 5.512 in	10 mm 0.394 in	5 mm 0.197 in
	SF4D-F23	SF4D-F23-01		23	230 mm 9.055 in	220 mm 8.661 in		
	SF4D-F31	SF4D-F31-01		31	310 mm 12.205 in	300 mm 11.811 in		
	SF4D-F39	SF4D-F39-01		39	390 mm 15.354 in	380 mm 14.961 in		
	SF4D-F47	SF4D-F47-01		47	470 mm 18.504 in	460 mm 18.110 in		
	SF4D-F55	SF4D-F55-01		55	550 mm 21.654 in	540 mm 21.260 in		
	SF4D-F63	SF4D-F63-01		63	630 mm 24.803 in	620 mm 24.409 in		
	SF4D-F71	SF4D-F71-01		71	710 mm 27.953 in	700 mm 27.559 in		
	SF4D-F79	SF4D-F79-01		79	790 mm 31.102 in	780 mm 30.709 in		
	SF4D-F95	SF4D-F95-01		95	950 mm 37.402 in	940 mm 37.008 in		
	SF4D-F111	SF4D-F111-01		111	1,110 mm 43.701 in	1,100 mm 43.307 in		
	SF4D-F127	SF4D-F127-01		127	1,270 mm 50.000 in	1,260 mm 49.606 in		
Hand protection type Min. sensing object $\phi 25$ mm $\phi 0.984$ in (20 mm $0.787$ in beam pitch)	SF4D-H8	SF4D-H8-01	0.2 to 9 m 0.656 to 29.528 ft (Short mode)	8	150 mm 5.906 in	140 mm 5.512 in	20 mm 0.787 in	5 mm 0.197 in
	SF4D-H12	SF4D-H12-01		12	230 mm 9.055 in	220 mm 8.661 in		
	SF4D-H16	SF4D-H16-01		16	310 mm 12.205 in	300 mm 11.811 in		
	SF4D-H20	SF4D-H20-01		20	390 mm 15.354 in	380 mm 14.961 in		
	SF4D-H24	SF4D-H24-01		24	470 mm 18.504 in	460 mm 18.110 in		
	SF4D-H28	SF4D-H28-01		28	550 mm 21.654 in	540 mm 21.260 in		
	SF4D-H32	SF4D-H32-01		32	630 mm 24.803 in	620 mm 24.409 in		
	SF4D-H36	SF4D-H36-01		36	710 mm 27.953 in	700 mm 27.559 in		
	SF4D-H40	SF4D-H40-01		40	790 mm 31.102 in	780 mm 30.709 in		
	SF4D-H48	SF4D-H48-01		48	950 mm 37.402 in	940 mm 37.008 in		
	SF4D-H56	SF4D-H56-01		56	1,110 mm 43.701 in	1,100 mm 43.307 in		
	SF4D-H64	SF4D-H64-01		64	1,270 mm 50.000 in	1,260 mm 49.606 in		
	SF4D-H72	SF4D-H72-01		72	1,430 mm 56.299 in	1,420 mm 55.906 in		
	SF4D-H80	SF4D-H80-01		80	1,590 mm 62.598 in	1,580 mm 62.205 in		
	SF4D-H88	SF4D-H88-01		88	1,750 mm 68.898 in	1,740 mm 68.504 in		
	SF4D-H96	SF4D-H96-01		96	1,910 mm 75.197 in	1,900 mm 74.803 in		
Arm / Foot protection type Min. sensing object $\phi 45$ mm $\phi 1.772$ in (40 mm $1.575$ in beam pitch)	SF4D-A4	SF4D-A4-01	0.2 to 9 m 0.656 to 29.528 ft (Short mode)	4	150 mm 5.906 in	120 mm 4.724 in	40 mm 1.575 in	15 mm 0.591 in
	SF4D-A6	SF4D-A6-01		6	230 mm 9.055 in	200 mm 7.874 in		
	SF4D-A8	SF4D-A8-01		8	310 mm 12.205 in	280 mm 11.024 in		
	SF4D-A10	SF4D-A10-01		10	390 mm 15.354 in	360 mm 14.173 in		
	SF4D-A12	SF4D-A12-01		12	470 mm 18.504 in	440 mm 17.323 in		
	SF4D-A14	SF4D-A14-01		14	550 mm 21.654 in	520 mm 20.472 in		
	SF4D-A16	SF4D-A16-01		16	630 mm 24.803 in	600 mm 23.622 in		
	SF4D-A18	SF4D-A18-01		18	710 mm 27.953 in	680 mm 26.772 in		
	SF4D-A20	SF4D-A20-01		20	790 mm 31.102 in	760 mm 29.921 in		
	SF4D-A24	SF4D-A24-01		24	950 mm 37.402 in	920 mm 36.220 in		
	SF4D-A28	SF4D-A28-01		28	1,110 mm 43.701 in	1,080 mm 42.520 in		
	SF4D-A32	SF4D-A32-01		32	1,270 mm 50.000 in	1,240 mm 48.819 in		
	SF4D-A36	SF4D-A36-01		36	1,430 mm 56.299 in	1,400 mm 55.118 in		
	SF4D-A40	SF4D-A40-01		40	1,590 mm 62.598 in	1,560 mm 61.417 in		
	SF4D-A44	SF4D-A44-01		44	1,750 mm 68.898 in	1,720 mm 67.717 in		
	SF4D-A48	SF4D-A48-01		48	1,910 mm 75.197 in	1,880 mm 74.016 in		

Notes: 1) The operating range is the possible setting distance between the emitter and the receiver.

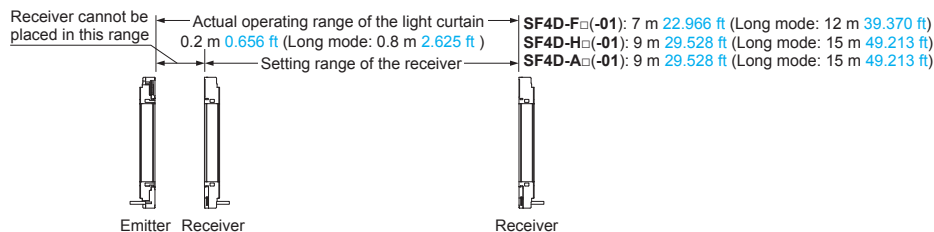

2) In the case of "When used as safety device for presses in China" or "When SF4D-□-01 is used for presses or shearing machines (paper cutting machines) in Japan," the distance between the center of the first beam axis and the center of the last beam axis of the device becomes the protective height.

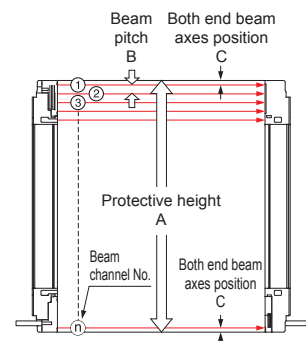



# ORDER GUIDE

## 2 Mounting brackets Mounting bracket is not supplied with the safety light curtain. Be sure to order it separately.

Designation	Model No.	Description	
Beam adjustment mounting bracket	<b>MS-SFD-1-5</b>	For mounting with M5 / M8 hexagon-socket head bolt	Mounting bracket for rear or side installation of safety light curtain. 4 pcs./set for emitter and receiver Material: Cold rolled carbon steel (SPCC)
	<b>MS-SFD-1-6</b>	For mounting with M6 hexagon-socket head bolt	
	<b>MS-SFD-1-8</b>	For mounting with M8 hexagon-socket head bolt	
Dead zoneless beam adjustment mounting bracket (Note 1)	<b>MS-SFD-3-6</b>	Dead zoneless mounting is possible in which mounting brackets do not extend beyond the protective height. (4 pcs./set for emitter and receiver) Material: Die-cast zinc alloy	
Intermediate supporting bracket (Note 2)	<b>MS-SFB-2</b>	This bracket holds the safety light curtain at the middle. (2 pcs./set for emitter and receiver) Use when installing the safety light curtain in a location subject to vibration Material: Die-cast zinc alloy	
SF4B-G compatible mounting bracket	<b>MS-SFD-4BG</b>	Mounting bracket for replacement of previous SF4B-□G□<V2> model with this device. (4 pcs./set for emitter and receiver) There is no need to change the mounting hole pitch. Material: Cold rolled carbon steel (SPCC)	

Notes: 1) The required numbers of emitters and receivers vary depending on the number of beam channels. For details, refer to **DIMENSIONS** (p.42).  
2) When the number of beam channels is **SF4D-F□(-01)**: 111 or more beam channels, **SF4D-H□(-01)**: 56 or more beam channels, **SF4D-A□(-01)**: 28 or more beam channels, one set is required.

### Dead zoneless beam adjustment mounting bracket

- **MS-SFD-3-6** (4 pcs./set for emitter and receiver)

#### <Rear mounting>

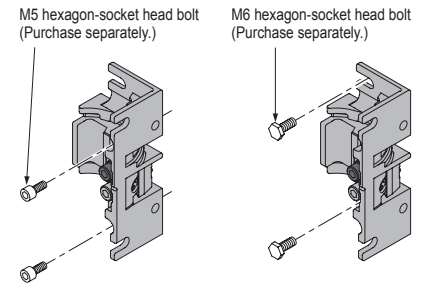

#### <Side mounting>

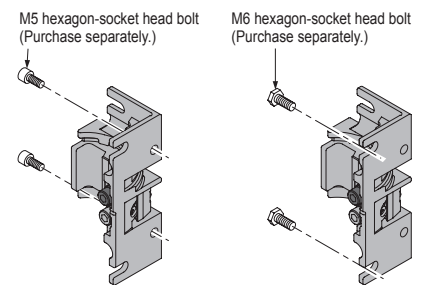

### Beam adjustment mounting bracket

- **MS-SFD-1-5** (4 pcs./set for emitter and receiver)

When using M5 hexagon-socket head bolt

M5 hexagon-socket head bolt  
(Purchase separately.)

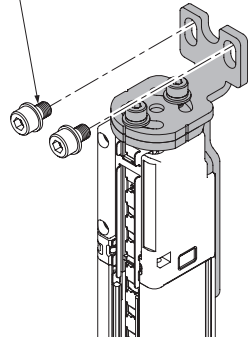

When using M8 hexagon-socket head bolt

M8 hexagon-socket head bolt  
(Purchase separately.)

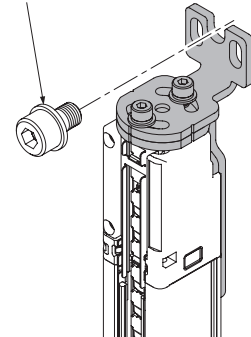

- **MS-SFD-1-6**  
(4 pcs./set for emitter and receiver)

M6 hexagon-socket head bolt  
(Purchase separately.)

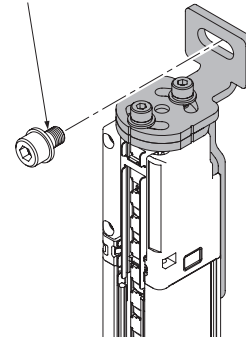

- **MS-SFD-1-8**  
(4 pcs./set for emitter and receiver)

M8 hexagon-socket head bolt  
(Purchase separately.)

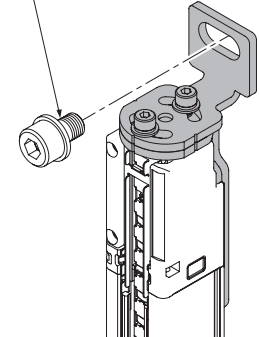

### Intermediate supporting bracket

- **MS-SFB-2** (2 pcs./set for emitter and receiver)

#### <Rear mounting>

M5 hexagon-socket head bolt  
(Purchase separately.)

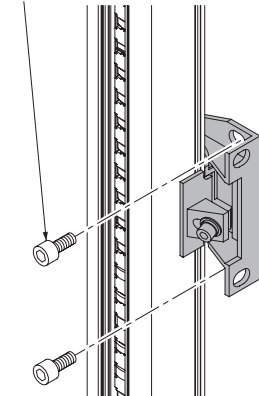

#### <Side mounting>

M5 hexagon-socket head bolt  
(Purchase separately.)

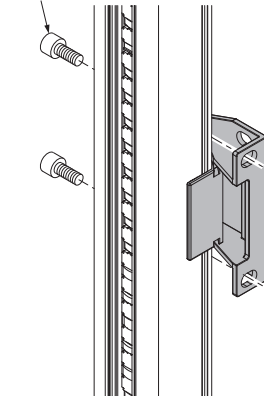

### SF4B-G compatible mounting bracket

- **MS-SFD-4BG** (4 pcs./set for emitter and receiver)

When using M5 hexagon-socket head bolt

M5 hexagon-socket head bolt  
(Purchase separately.)

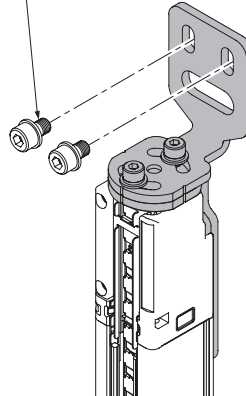

When using M8 hexagon-socket head bolt

M8 hexagon-socket head bolt  
(Purchase separately.)

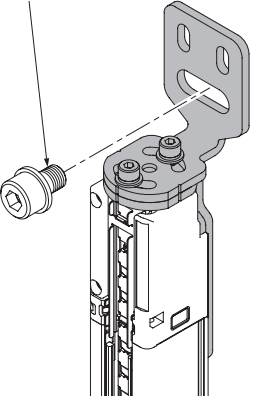

# ORDER GUIDE

**3 4 5 6** Mating cable / Extension cable Mating cable is not supplied with the safety light curtain. Be sure to order it separately.



When using **SF4D-□-01** as a safety device for a press machine or paper shearing machine in Japan, always attach the protective tube **SFPD-A10** (tube length: 10 m **32.808 ft**) (optional) to the cable.

Type		Appearance	Model No.	Description (Note)		
Standard components (5-core cable)	Bottom cap cable	Discrete wire	<b>SFD-CCB5-S</b>	Length: 5 m <b>16.404 ft</b> Net weight: 420 g approx. (2 cables)	Used for connecting to the safety light curtain and to other cables or the <b>SF-C13</b> / <b>SF-C21</b> control unit. 2 cables/set for emitter and receiver	
			<b>SFD-CCB10-S</b>	Length: 10 m <b>32.808 ft</b> Net weight: 830 g approx. (2 cables)		
		Connector	<b>SFD-CB05-S</b>	Length: 0.5 m <b>1.640 ft</b> Net weight: 75 g approx. (2 cables)		Used for connecting to the safety light curtain and to an extension cable. 2 cables/set for emitter and receiver Connector outer diameter: ø14 mm <b>ø0.551 in</b> max. M12 male connector
	Extension cable	With connector on one end	<b>SFD-CC3-S</b>	Length: 3 m <b>9.843 ft</b> Net weight: 260 g approx. (2 cables)		Used for cable extension or connecting to the <b>SF-C13</b> / <b>SF-C21</b> control unit. 2 cables/set for emitter and receiver Connector outer diameter: ø14 mm <b>ø0.551 in</b> max. M12 female connector
			<b>SFD-CC10-S</b>	Length: 10 m <b>32.808 ft</b> Net weight: 830 g approx. (2 cables)		
	Extension cable	With connectors on both ends	For emitter	<b>SFD-CCJ10E-S</b>	Length: 10 m <b>32.808 ft</b> Net weight: 420 g approx. (1 cable)	1 cable for emitter Connector color: Gray Used for cable extension Connector outer diameter: ø14 mm <b>ø0.551 in</b> max. M12 female-male connector
				For receiver	<b>SFD-CCJ10D-S</b>	
	Standard components (8-core cable)	Bottom cap cable	Discrete wire		<b>SFD-CCB3</b>	Length: 3 m <b>9.843 ft</b> Net weight: 290 g approx. (2 cables)
				<b>SFD-CCB7</b>	Length: 7 m <b>22.966 ft</b> Net weight: 620 g approx. (2 cables)	
				<b>SFD-CCB10</b>	Length: 10 m <b>32.808 ft</b> Net weight: 900 g approx. (2 cables)	
<b>SFD-CCB15</b>				Length: 15 m <b>49.213 ft</b> Net weight: 1,300 g approx. (2 cables)		
Bottom cap cable		Connector	<b>SFD-CB05</b>	Length: 0.5 m <b>1.640 ft</b> Net weight: 80 g approx. (2 cables)	Used for connecting to the safety light curtain and to an extension cable or the <b>SF-C11</b> control unit. 2 cables/set for emitter and receiver Connector outer diameter: ø14 mm <b>ø0.551 in</b> max. M12 male connector	
			<b>SFD-CB5</b>	Length: 5 m <b>16.404 ft</b> Net weight: 480 g approx. (2 cables)		
			<b>SFD-CB10</b>	Length: 10 m <b>32.808 ft</b> Net weight: 950 g approx. (2 cables)		
Extension cable		With connector on one end	<b>SFD-CC3</b>	Length: 3 m <b>9.843 ft</b> Net weight: 290 g approx. (2 cables)	Used for connecting to an extension cable or the <b>SF-C13</b> / <b>SF-C21</b> control unit. 2 cables/set for emitter and receiver Connector outer diameter: ø14 mm <b>ø0.551 in</b> max. M12 female connector	
			<b>SFD-CC10</b>	Length: 10 m <b>32.808 ft</b> Net weight: 900 g approx. (2 cables)		
		With connectors on both ends	For emitter	<b>SFB-CCJ3E</b>	Length: 3 m <b>9.843 ft</b> Net weight: 190 g approx. (1 cable)	1 cable for emitter Connector color: Gray Used for connecting to an extension cable or the <b>SF-C11</b> control unit. Connector outer diameter: ø14 mm <b>ø0.551 in</b> max. M12 female-male connector
	<b>SFB-CCJ10E</b>			Length: 10 m <b>32.808 ft</b> Net weight: 580 g approx. (1 cable)		
Extension cable	For receiver	<b>SFB-CCJ3D</b>	Length: 3 m <b>9.843 ft</b> Net weight: 210 g approx. (1 cable)	1 cable for receiver Connector color: Black		
		<b>SFB-CCJ10D</b>	Length: 10 m <b>32.808 ft</b> Net weight: 600 g approx. (1 cable)			
Compatible cable	For <b>SF4-AH□</b> (PNP type)		<b>SFD-CB05-A-P</b>	Length: 0.5 m <b>1.640 ft</b> Net weight: 80 g approx. (2 cables)	8-core bottom cap cables. The connector cables (on control circuit side) used with previous safety light curtains can be connected without any modification, thus enabling easy replacement of the existing devices with the <b>SF4D</b> series products. 2 cables/set for emitter and receiver Connector outer diameter: ø14 mm <b>ø0.551 in</b> max. M12 male connector	
	For <b>SF4-AH□-N</b> (NPN type)		<b>SFD-CB05-A-N</b>			

Note: Where the cable color has not been specified, it is gray for emitter, gray with black line for receiver, outer diameter is ø5.7 mm **ø0.224 in** or ø6 mm **ø0.236 in**, min. bending radius is R6 mm **R0.236 in**.

The minimum bending radius of the cable with the protective tube **SFPD-A10** attached is R55 mm **R2.165 in**.

# ORDER GUIDE

## 7 8 9 10 Mating cable / Extension cable / Cables for series connection / Protective tube

Mating cable is not supplied with the safety light curtain. Be sure to order it separately.



When using **SF4D-□-01** as a safety device for a press machine or paper shearing machine in Japan, always attach the protective tube **SFPD-A10** (tube length: 10 m **32.808 ft**) (optional) to the cable.

Type	Appearance	Model No.	Description (Note)				
Standard components (12-core cable)	Bottom cap cable	Discrete wire		<b>SFD-CCB3-MU</b> Length: 3 m <b>9.843 ft</b> Net weight: 340 g approx. (2 cables)	Used for connecting to the safety light curtain and to other cables or the <b>SF-C13</b> / <b>SF-C21</b> control unit. 2 cables/set for emitter and receiver		
				<b>SFD-CCB7-MU</b> Length: 7 m <b>22.966 ft</b> Net weight: 700 g approx. (2 cables)			
				<b>SFD-CCB10-MU</b> Length: 10 m <b>32.808 ft</b> Net weight: 980 g approx. (2 cables)			
	7	Connector		<b>SFD-CB05-MU</b> Length: 0.5 m <b>1.640 ft</b> Net weight: 95 g approx. (2 cables)	Used for connecting to the safety light curtain and to an extension cable. 2 cables/set for emitter and receiver Connector outer diameter: $\phi$ 16 mm <b><math>\phi</math>0.630 in</b> max. M14 male connector		
				8	With connector on one end		<b>SFD-CC3-MU</b> Length: 3 m <b>9.843 ft</b> Net weight: 340 g approx. (2 cables)
	<b>SFD-CC7-MU</b> Length: 7 m <b>22.966 ft</b> Net weight: 700 g approx. (2 cables)						
	<b>SFD-CC10-MU</b> Length: 10 m <b>32.808 ft</b> Net weight: 980 g approx. (2 cables)						
	8	With connectors on both ends	For emitter		<b>SFB-CCJ3E-MU</b> Length: 3 m <b>9.843 ft</b> Net weight: 190 g approx. (1 cable)	1 cable for emitter Connector color: Gray	
					<b>SFB-CCJ10E-MU</b> Length: 10 m <b>32.808 ft</b> Net weight: 660 g approx. (1 cable)		
					For receiver	<b>SFB-CCJ3D-MU</b> Length: 3 m <b>9.843 ft</b> Net weight: 210 g approx. (1 cable)	1 cable for receiver Connector color: Black
						<b>SFB-CCJ10D-MU</b> Length: 10 m <b>32.808 ft</b> Net weight: 680 g approx. (1 cable)	
	9	Cable for series connection		<b>SFD-CSL005</b> Length: 0.05 m <b>0.164 ft</b> Net weight: 35 g approx. (2 cables)	Used to connect safety light curtains in series. 2 cables/set for emitter and receiver (common for emitter and receiver) Cable color: Gray with black line (common for emitter and receiver)		
<b>SFD-CSL01</b> Length: 0.1 m <b>0.328 ft</b> Net weight: 40 g approx. (2 cables)							
<b>SFD-CSL05</b> Length: 0.5 m <b>1.640 ft</b> Net weight: 80 g approx. (2 cables)							
<b>SFD-CSL1</b> Length: 1 m <b>3.281 ft</b> Net weight: 130 g approx. (2 cables)							
<b>SFD-CSL5</b> Length: 5 m <b>16.404 ft</b> Net weight: 480 g approx. (2 cables)							
<b>SFD-CSL10</b> Length: 10 m <b>32.808 ft</b> Net weight: 950 g approx. (2 cables)							
10	Protective tube		<b>SFPD-A10</b> Tube length: 10 m <b>32.808 ft</b> Net weight: 220 g approx. (1 tube)	Protective tubes must be installed to the cables when <b>SF4D-□-01</b> is used as a safety device for a press or shearing machine (paper cutting machine) in Japan. Outside diameter: $\phi$ 13 mm <b><math>\phi</math>0.512 in</b> approx., Inside diameter: $\phi$ 9 mm <b><math>\phi</math>0.354 in</b> Material: Polypropylene			



Note: Where the cable color has not been specified, it is gray for emitter, gray with black line for receiver, outer diameter is  $\phi$ 5.7 mm  **$\phi$ 0.224 in** or  $\phi$ 6 mm  **$\phi$ 0.236 in**, min. bending radius is R6 mm **R0.236 in**. The minimum bending radius of the cable with the protective tube **SFPD-A10** attached is R55 mm **R2.165 in**.

### Spare parts (Accessories for safety light curtain)

Designation	Model No.	Description
Test rod $\phi$ 14	<b>SF4B-TR14</b>	Min. sensing object for regular checking ( $\phi$ 14 mm <b><math>\phi</math>0.551 in</b> ), with finger protection type (min. sensing object $\phi$ 14 mm <b><math>\phi</math>0.551 in</b> )
Test rod $\phi$ 25	<b>SF4B-TR25</b>	Min. sensing object for regular checking ( $\phi$ 25 mm <b><math>\phi</math>0.984 in</b> ), with hand protection type (min. sensing object $\phi$ 25 mm <b><math>\phi</math>0.984 in</b> )

## OPTIONS

### Control units

Type	Appearance	Model No.	Application cable	Description (Note)
Safety control unit		<b>SF-C21</b>	Safety light curtain Bottom cap cable: <b>SFD-CCB</b> □ Extension cable: <b>SFD-CC</b> □	Use a discrete wire cable to connect to the safety light curtain. Logic customization, monitoring, and simulation functions are also provided. Compatible with up to Control Category 4.
Connector connection type control unit (Supports presses used in Japan)		<b>SF-C11</b>	Safety light curtain Bottom cap cable: <b>SFD-CB</b> □ Extension cable: <b>SFB-CCJ</b> □ (M12 connector)	Use 8-core cable with connector to connect to the safety light curtain. Muting function cannot be used. Compatible with up to Control Category 4. Supports presses used in Japan when combined with <b>SF4D-□-01</b> (shearing machines not supported)
Slim type control unit (Supports presses used in Japan)		<b>SF-C13</b>	Safety light curtain Bottom cap cable: <b>SFD-CCB</b> □ Extension cable: <b>SFD-CC</b> □	Use a discrete wire cable to connect to the safety light curtain. Muting function can be used. Compatible with up to Control Category 4. Supports presses used in Japan when combined with <b>SF4D-□-01</b> (shearing machines not supported)

### •Recommended safety relays

SF relay, slim type

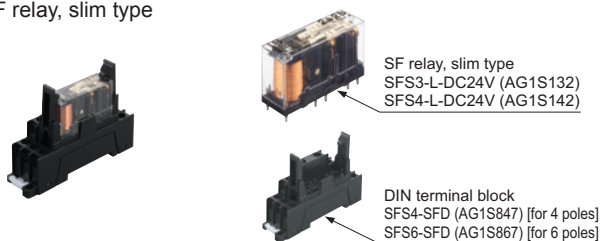

Note: Please contact our sales office for details on the recommended products.

Type	With LED indicator		
	Model No.	SFS3-L-DC24V	SFS4-L-DC24V
Item	Part No.	AG1S132	AG1S142
Contact arrangement		3a1b	4a2b
Rated nominal switching capacity		6 A / 250 V AC, 6 A / 30 V DC	
Min. switching capacity		1 mA / 5 V DC	
Coil rating		15 mA / 24 V DC	20.8 mA / 24 V DC
Rated power consumption		360 mW	500 mW
Operation time		20 ms or less	
Release time		20 ms or less	
Ambient temperature		-40 to +85 °C <b>-40 to +185 °F</b> (Humidity: 5 to 85 % RH)	
Applicable certifications		UL/c-UL, TÜV, Korea S-mark	

### Communication module

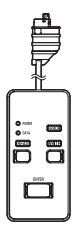
Type	Appearance	Model No.	Description
Communication module		<b>SF4D-TM1</b>	The setting software, <b>Configurator Light Curtain</b> , is required when using the <b>SF4D-TM1</b> communication module. The setting software can be downloaded free from our website. USB cable is not provided with the product. USB2.0 cable (A: Mini-B) must be prepared by the user. <b>&lt;In the case of SF4D-F□/H□/A□&gt;</b> The communication module serves as a conversion module for the connection of a PC to the <b>SF4D</b> series for changing function settings and monitoring statuses (light incidence / light blockage, lockout, etc.). The communication module can also be used to copy settings from <b>SF4D</b> series products without the connection of a PC. <b>&lt;In the case of SF4D-□-01&gt;</b> The communication module serves as a conversion module for the connection of a PC to the <b>SF4D</b> series for monitoring statuses (light incidence / light blockage, lockout, etc.). The communication module cannot be used by itself.

### IO-Link communication unit

Type	Appearance	Model No.	Description
IO-Link communication unit		<b>SFD-WL3</b>	For use with <b>SF4D</b> series This unit enables the confirmation of various settings and operating status of the <b>SF4D</b> series from a host device using IO-Link communication. It can also save the setting information of the connected <b>SF4D</b> series unit.

## OPTIONS

### Front protection cover / Corner mirror

Designation			Front protection cover (wide type) (Note 1)	Front protection cover (slim type) (Note 1)	Corner mirror (Note 1, 2)	
Applicable beam axes					Model No.	Model No.
Finger	Hand	Arm / Foot	Model No.	Model No.	Model No.	Effective reflective surface
15	8	4	<b>FC-SFDH-8</b>	<b>FC-SFDH-8-S</b>	<b>RF-SFBH-8</b>	173 × 72 mm <b>6.811 × 2.835 in</b>
23	12	6	<b>FC-SFDH-12</b>	<b>FC-SFDH-12-S</b>	<b>RF-SFBH-12</b>	236 × 72 mm <b>9.291 × 2.835 in</b>
31	16	8	<b>FC-SFDH-16</b>	<b>FC-SFDH-16-S</b>	<b>RF-SFBH-16</b>	316 × 72 mm <b>12.441 × 2.835 in</b>
39	20	10	<b>FC-SFDH-20</b>	<b>FC-SFDH-20-S</b>	<b>RF-SFBH-20</b>	396 × 72 mm <b>15.591 × 2.835 in</b>
47	24	12	<b>FC-SFDH-24</b>	<b>FC-SFDH-24-S</b>	<b>RF-SFBH-24</b>	476 × 72 mm <b>18.740 × 2.835 in</b>
55	28	14	<b>FC-SFDH-28</b>	<b>FC-SFDH-28-S</b>	<b>RF-SFBH-28</b>	556 × 72 mm <b>21.890 × 2.835 in</b>
63	32	16	<b>FC-SFDH-32</b>	<b>FC-SFDH-32-S</b>	<b>RF-SFBH-32</b>	636 × 72 mm <b>25.039 × 2.835 in</b>
71	36	18	<b>FC-SFDH-36</b>	<b>FC-SFDH-36-S</b>	<b>RF-SFBH-36</b>	716 × 72 mm <b>28.189 × 2.835 in</b>
79	40	20	<b>FC-SFDH-40</b>	<b>FC-SFDH-40-S</b>	<b>RF-SFBH-40</b>	796 × 72 mm <b>31.339 × 2.835 in</b>
95	48	24	<b>FC-SFDH-48</b>	<b>FC-SFDH-48-S</b>	<b>RF-SFBH-48</b>	956 × 72 mm <b>37.638 × 2.835 in</b>
111	56	28	<b>FC-SFDH-56</b>	<b>FC-SFDH-56-S</b>	<b>RF-SFBH-56</b>	1,116 × 72 mm <b>43.937 × 2.835 in</b>
127	64	32	<b>FC-SFDH-64</b>	<b>FC-SFDH-64-S</b>	<b>RF-SFBH-64</b>	1,276 × 72 mm <b>50.236 × 2.835 in</b>
—	72	36	<b>FC-SFDH-72</b>	<b>FC-SFDH-72-S</b>	<b>RF-SFBH-72</b>	1,436 × 72 mm <b>56.535 × 2.835 in</b>
—	80	40	<b>FC-SFDH-80</b>	<b>FC-SFDH-80-S</b>	<b>RF-SFBH-80</b>	1,596 × 72 mm <b>62.835 × 2.835 in</b>
—	88	44	<b>FC-SFDH-88</b>	<b>FC-SFDH-88-S</b>	<b>RF-SFBH-88</b>	1,756 × 72 mm <b>69.134 × 2.835 in</b>
—	96	48	<b>FC-SFDH-96</b>	<b>FC-SFDH-96-S</b>	<b>RF-SFBH-96</b>	1,916 × 72 mm <b>75.433 × 2.835 in</b>

Notes: 1) The model Nos. given above denote a single unit, not a pair of units. 2 units are required for use in mounting to the emitter / receiver. (Except for corner mirror)  
2) The corner mirror has not received type examination by the Ministry of Health, Labour and Welfare; therefore, it cannot be used for presses or shearing machines (paper cutting machines) in Japan.

#### Front protection cover

Protects sensing surface of the safety light curtain from flying objects such as welding spatter. The operating range reduces when the front protection cover is used.

##### • FC-SFDH-□ (wide type)

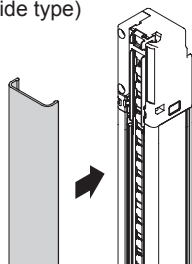

Material: Polycarbonate

##### • FC-SFDH-□-S (slim type)

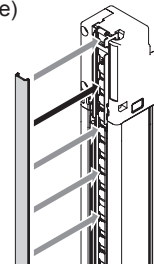

Material: Polycarbonate

#### • Operating range

Front protection cover			Operating range (Note)	
			Short mode	Long mode
Finger	FC-SFDH-□ (wide type) FC-SFDH-□-S (slim type)	Only emitter installed	0.2 to 6 m <b>0.656 to 19.685 ft</b>	0.8 to 9.5 m <b>2.625 to 31.168 ft</b>
		Only receiver installed	0.2 to 6 m <b>0.656 to 19.685 ft</b>	0.8 to 9.5 m <b>2.625 to 31.168 ft</b>
		Both emitter and receiver installed	0.2 to 5.5 m <b>0.656 to 18.045 ft</b>	0.8 to 9 m <b>2.625 to 29.528 ft</b>
Hand, Arm / Foot	FC-SFDH-□ (wide type) FC-SFDH-□-S (slim type)	Only emitter installed	0.2 to 7.5 m <b>0.656 to 24.606 ft</b>	0.8 to 12 m <b>2.625 to 39.370 ft</b>
		Only receiver installed	0.2 to 7.5 m <b>0.656 to 24.606 ft</b>	0.8 to 12 m <b>2.625 to 39.370 ft</b>
		Both emitter and receiver installed	0.2 to 7 m <b>0.656 to 22.966 ft</b>	0.8 to 11 m <b>2.625 to 36.089 ft</b>

Note: The operating range is the possible setting distance between the emitter and the receiver.

#### Corner mirror

##### • RF-SFBH-□

Normally for L-shaped or U-shaped installation, 2 or 3 sets of safety light curtains are needed. With the use of a corner mirror reflecting the light, one set of safety light curtain is possible for L-shaped or U-shaped installation.

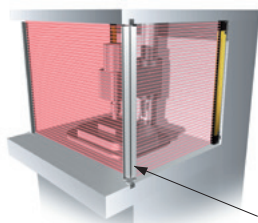

Corner mirror  
RF-SFBH-□

#### • Operating range

With 1 corner mirror	Declined to 90 %
With 2 corner mirrors	Declined to 80 %
With 3 corner mirrors	Declined to 70 %

\* The corner mirror has not received type examination by the Ministry of Health, Labour and Welfare; therefore, it cannot be used for presses or shearing machines (paper cutting machines) in Japan.

### Test rod / Laser alignment tool

Type	Model No.	Description
Test rod ø45	<b>SF4B-TR45</b>	Min. sensing object for regular checking (ø45 mm <b>ø1.772 in</b> ), with arm / foot protection type (min. sensing object ø45 mm <b>ø1.772 in</b> )
Laser alignment tool	<b>SF-LAT-2N</b>	Allows easy beam axis alignment using easy-to-see laser beam

#### Laser alignment tool

##### • SF-LAT-2N

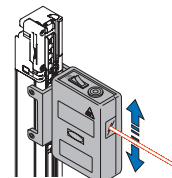

# OPTIONS

## Y-shaped connector

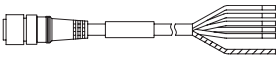
Type	Appearance	Model No.	Description
Wire-saving Y-shaped connector		<b>SFB-WY1</b>	Wire-saving connector for standard components (8-core cable). Cables of emitter and receiver are consolidated into one cable for wire-saving. Wiring has +24 V, 0 V, OSSD 1, OSSD 2, output polarity setting wire, and lockout release input. [Power wire and synchronization wire are connected inside the connector.] Interlock is disabled (automatic reset). Net weight: 35 g approx. M12 female-male connector
Cable with connector on one side		<b>WY1-CCN3</b>	Cable length: 3 m <b>9.843 ft</b> Net weight: 200 g approx. (1 cable)
		<b>WY1-CCN10</b>	Cable length: 10 m <b>32.808 ft</b> Net weight: 620 g approx. (1 cable)
			Mating cable for Y-shaped connector Cable color: Gray (with black line) Connector color: Black The min. bending radius: R6 mm <b>R0.236 in</b> Connector outer diameter: $\phi$ 14 mm <b><math>\phi</math>0.551 in</b> M12 female connector

By using the Y-shaped connector, the least required wires such as power or safety output are consolidated into one cable. Man-hours taken for wiring is eliminated to the minimum. Construction times as well as wiring mistakes are greatly reduced.

**Previous** A total of 16 wires (8-core cable)



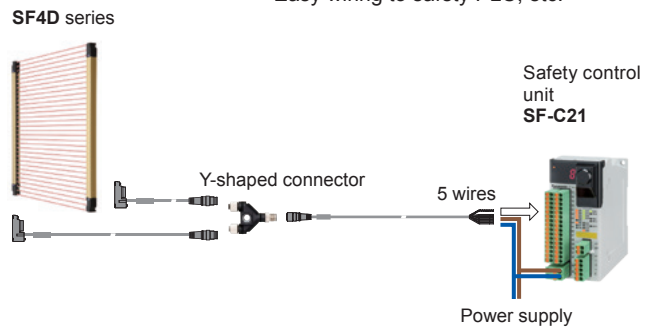
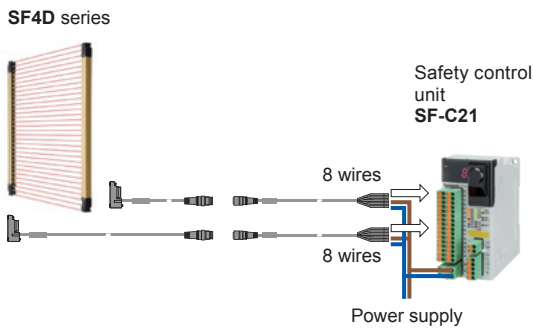

**Y-shaped connector**

- Only 5 wires
- Less wiring mistakes! Reduced wiring time!
- Easy wiring to safety PLC, etc.

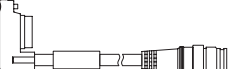

Refer to the instruction manual of Y-shaped connector and safety control unit for more detail such as installation of Y-shaped connector, terminal wiring, and wiring example.

## SF4D conversion adapter (For replacing SF4B series with SF4D series)

Type	Appearance	Model No.	Description
SF4D conversion adapter (Note)	For emitter 	<b>SFD-J4B</b>	This unit replaces the previous SF4B series (only when SFB-CCB□ and SFB-CCB□-MU discrete-wire bottom cap cables are used). The existing mounting holes, discrete-wire bottom cap cables and other wires for the previous SF4B series can be used to allow for easy and smooth installation. 1 set (one for emitter and one for receiver) Female connector (8-core: M12, 12-core: M14)
	For receiver 	<b>SFD-J4B-MU</b>	
SF4D bottom cap cable	For 8-core cable 	<b>SFD-CB05</b>	Length: 0.5 m <b>1.640 ft</b> Net weight: 80 g approx. (2 cables)
	For 12-core cable 	<b>SFD-CB05-MU</b>	Length: 0.5 m <b>1.640 ft</b> Net weight: 95 g approx. (2 cables)
			Used for connecting to the SF4D series main unit and to SF4D conversion adapter. 2 cables/set for emitter and receiver Cable color: Gray for emitter Gray with black line for receiver Min. bending radius: R6 mm Male connector (8-core: M12, 12-core: M14)

Note: This product is made to order.

**Previous**

**Replacing existing unit with SF4D series using SF4D conversion adapter**

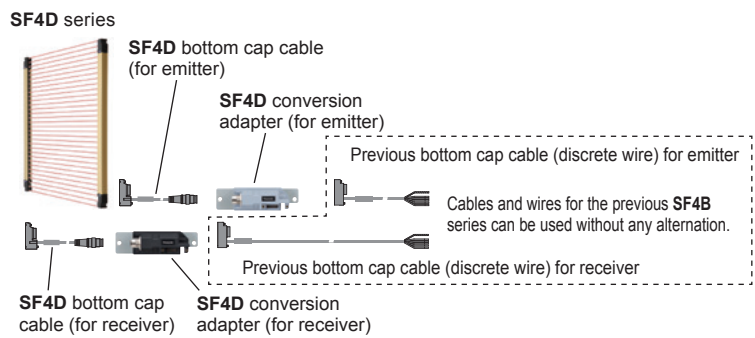
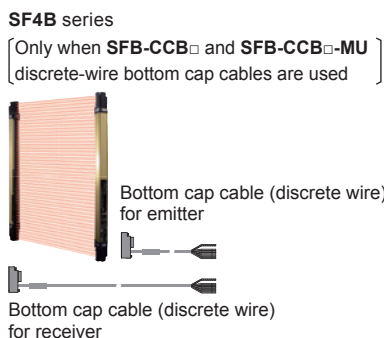

# SPECIFICATIONS

## Safety light curtain individual specifications

### SF4D-F□(-01) (Finger protection type)

Type		Min. sensing object ø14 mm ø0.551 in type (10 mm 0.394 in beam pitch)			
Item	Model No.	SF4D-F15(-01)	SFD-F23(-01)	SF4D-F31(-01)	SF4D-F39(-01)
Number of beam channels		15	23	31	39
Protective height (Note 2)		150 mm 5.906 in	230 mm 9.055 in	310 mm 12.205 in	390 mm 15.354 in
	When using as safety equipment for Chinese press machine or when using SF4D-□-01 for Japanese press machine or paper shearing machine	140 mm 5.512 in	220 mm 8.661 in	300 mm 11.811 in	380 mm 14.961 in
Current consumption		Emitter: 110 mA or less, Receiver: 130 mA or less		Emitter: 120 mA or less, Receiver: 130 mA or less	Emitter: 120 mA or less, Receiver: 140 mA or less
PFH <sub>D</sub> / MTTFD		1.21 × 10 <sup>-9</sup> / 1,031 years	1.48 × 10 <sup>-9</sup> / 833 years	1.80 × 10 <sup>-9</sup> / 672 years	2.07 × 10 <sup>-9</sup> / 582 years
Net weight (Total of emitter and receiver)		270 g approx.	470 g approx.	680 g approx.	890 g approx.

Item	Model No.	SF4D-F47(-01)	SF4D-F55(-01)	SF4D-F63(-01)	SF4D-F71(-01)
Number of beam channels		47	55	63	71
Protective height (Note 2)		470 mm 18.504 in	550 mm 21.654 in	630 mm 24.803 in	710 mm 27.953 in
	When using as safety equipment for Chinese press machine or when using SF4D-□-01 for Japanese press machine or paper shearing machine	460 mm 18.110 in	540 mm 21.260 in	620 mm 24.409 in	700 mm 27.559 in
Current consumption		Emitter: 120 mA or less, Receiver: 140 mA or less		Emitter: 120 mA or less, Receiver: 150 mA or less	
PFH <sub>D</sub> / MTTFD		2.40 × 10 <sup>-9</sup> / 498 years	2.66 × 10 <sup>-9</sup> / 447 years	2.99 × 10 <sup>-9</sup> / 396 years	3.25 × 10 <sup>-9</sup> / 363 years
Net weight (Total of emitter and receiver)		1,100 g approx.	1,300 g approx.	1,500 g approx.	1,700 g approx.

Item	Model No.	SF4D-F79(-01)	SF4D-F95(-01)	SF4D-F111(-01)	SF4D-F127(-01)
Number of beam channels		79	95	111	127
Protective height (Note 2)		790 mm 31.102 in	950 mm 37.402 in	1,110 mm 43.701 in	1,270 mm 50.000 in
	When using as safety equipment for Chinese press machine or when using SF4D-□-01 for Japanese press machine or paper shearing machine	780 mm 30.709 in	940 mm 37.008 in	1,100 mm 43.307 in	1,260 mm 49.606 in
Current consumption		Emitter: 120 mA or less, Receiver: 150 mA or less	Emitter: 120 mA or less, Receiver: 160 mA or less	Emitter: 120 mA or less, Receiver: 170 mA or less	Emitter: 120 mA or less, Receiver: 180 mA or less
PFH <sub>D</sub> / MTTFD		3.58 × 10 <sup>-9</sup> / 328 years	4.17 × 10 <sup>-9</sup> / 281 years	4.76 × 10 <sup>-9</sup> / 245 years	5.36 × 10 <sup>-9</sup> / 217 years
Net weight (Total of emitter and receiver)		1,900 g approx.	2,300 g approx.	2,800 g approx.	3,200 g approx.

### SF4D-H□(-01) (Hand protection type)

Type		Min. sensing object ø25 mm ø0.984 in type (20 mm 0.787 in beam pitch)			
Item	Model No.	SF4D-H8(-01)	SF4D-H12(-01)	SF4D-H16(-01)	SF4D-H20(-01)
Number of beam channels		8	12	16	20
Protective height (Note 2)		150 mm 5.906 in	230 mm 9.055 in	310 mm 12.205 in	390 mm 15.354 in
	When using as safety equipment for Chinese press machine or when using SF4D-□-01 for Japanese press machine or paper shearing machine	140 mm 5.512 in	220 mm 8.661 in	300 mm 11.811 in	380 mm 14.961 in
Current consumption		Emitter: 100 mA or less, Receiver: 120 mA or less			
PFH <sub>D</sub> / MTTFD		9.57 × 10 <sup>-10</sup> / 1,340 years	1.12 × 10 <sup>-9</sup> / 1,119 years	1.26 × 10 <sup>-9</sup> / 988 years	1.40 × 10 <sup>-9</sup> / 881 years
Net weight (Total of emitter and receiver)		270 g approx.	470 g approx.	680 g approx.	890 g approx.

Item	Model No.	SF4D-H24(-01)	SF4D-H28(-01)	SF4D-H32(-01)	SF4D-H36(-01)
Number of beam channels		24	28	32	36
Protective height (Note 2)		470 mm 18.504 in	550 mm 21.654 in	630 mm 24.803 in	710 mm 27.953 in
	When using as safety equipment for Chinese press machine or when using SF4D-□-01 for Japanese press machine or paper shearing machine	460 mm 18.110 in	540 mm 21.260 in	620 mm 24.409 in	700 mm 27.559 in
Current consumption		Emitter: 100 mA or less, Receiver: 130 mA or less	Emitter: 110 mA or less, Receiver: 130 mA or less		Emitter: 120 mA or less, Receiver: 130 mA or less
PFH <sub>D</sub> / MTTFD		1.56 × 10 <sup>-9</sup> / 782 years	1.73 × 10 <sup>-9</sup> / 701 years	1.87 × 10 <sup>-9</sup> / 647 years	2.04 × 10 <sup>-9</sup> / 591 years
Net weight (Total of emitter and receiver)		1,100 g approx.	1,300 g approx.	1,500 g approx.	1,700 g approx.

Notes: 1) Where measurement conditions have not been specified precisely, the conditions used were an ambient temperature of +20 °C +68 °F.

PFH<sub>D</sub>: Probability of dangerous failure per hour, MTTFD: Mean time to dangerous failure (in years)

2) In the case of "When used as safety device for presses in China" or "When SF4D-□-01 is used for presses or shearing machines (paper cutting machines) in Japan," the distance between the center of the first beam axis and the center of the last beam axis of the device becomes the protective height.

## SPECIFICATIONS

Type		Min. sensing object $\varnothing 25$ mm $\varnothing 0.984$ in type (20 mm $0.787$ in beam pitch)			
Item	Model No.	SF4D-H40(-01)	SF4D-H48(-01)	SF4D-H56(-01)	SF4D-H64(-01)
Number of beam channels		40	48	56	64
Protective height (Note 2)		790 mm $31.102$ in	950 mm $37.402$ in	1,110 mm $43.701$ in	1,270 mm $50.000$ in
	When using as safety equipment for Chinese press machine or when using SF4D-□-01 for Japanese press machine or paper shearing machine	780 mm $30.709$ in	940 mm $37.008$ in	1,100 mm $43.307$ in	1,260 mm $49.606$ in
Current consumption		Emitter: 120 mA or less, Receiver: 140 mA or less			Emitter: 120 mA or less, Receiver: 150 mA or less
PFH <sub>D</sub> / MTTFD <sub>D</sub>		$2.17 \times 10^{-9}$ / 552 years	$2.48 \times 10^{-9}$ / 481 years	$2.78 \times 10^{-9}$ / 426 years	$3.09 \times 10^{-9}$ / 383 years
Net weight (Total of emitter and receiver)		1,900 g approx.	2,300 g approx.	2,800 g approx.	3,200 g approx.

Type		Min. sensing object $\varnothing 25$ mm $\varnothing 0.984$ in type (20 mm $0.787$ in beam pitch)			
Item	Model No.	SF4D-H72(-01)	SF4D-H80(-01)	SF4D-H88(-01)	SF4D-H96(-01)
Number of beam channels		72	80	88	96
Protective height (Note 2)		1,430 mm $56.299$ in	1,590 mm $62.598$ in	1,750 mm $68.898$ in	1,910 mm $75.197$ in
	When using as safety equipment for Chinese press machine or when using SF4D-□-01 for Japanese press machine or paper shearing machine	1,420 mm $55.906$ in	1,580 mm $62.205$ in	1,740 mm $68.504$ in	1,900 mm $74.803$ in
Current consumption		Emitter: 120 mA or less, Receiver: 150 mA or less		Emitter: 120 mA or less, Receiver: 160 mA or less	
PFH <sub>D</sub> / MTTFD <sub>D</sub>		$3.39 \times 10^{-9}$ / 347 years	$3.69 \times 10^{-9}$ / 318 years	$4.00 \times 10^{-9}$ / 293 years	$4.30 \times 10^{-9}$ / 272 years
Net weight (Total of emitter and receiver)		3,600 g approx.	4,000 g approx.	4,400 g approx.	4,800 g approx.

### SF4D-A□(-01) (Arm / Foot protection type)

Type		Min. sensing object $\varnothing 45$ mm $\varnothing 1.772$ in type (40 mm $1.575$ in beam pitch)			
Item	Model No.	SF4D-A4(-01)	SF4D-A6(-01)	SF4D-A8(-01)	SF4D-A10(-01)
Number of beam channels		4	6	8	10
Protective height (Note 2)		150 mm $5.906$ in	230 mm $9.055$ in	310 mm $12.205$ in	390 mm $15.354$ in
	When using as safety equipment for Chinese press machine or when using SF4D-□-01 for Japanese press machine or paper shearing machine	120 mm $4.724$ in	200 mm $7.874$ in	280 mm $11.024$ in	360 mm $14.173$ in
Current consumption		Emitter: 100 mA or less, Receiver: 120 mA or less			
PFH <sub>D</sub> / MTTFD <sub>D</sub>		$8.29 \times 10^{-10}$ / 1,577 years	$9.34 \times 10^{-10}$ / 1,378 years	$1.01 \times 10^{-9}$ / 1,267 years	$1.11 \times 10^{-9}$ / 1,136 years
Net weight (Total of emitter and receiver)		270 g approx.	470 g approx.	680 g approx.	890 g approx.

Type		Min. sensing object $\varnothing 45$ mm $\varnothing 1.772$ in type (40 mm $1.575$ in beam pitch)			
Item	Model No.	SF4D-A12(-01)	SF4D-A14(-01)	SF4D-A16(-01)	SF4D-A18(-01)
Number of beam channels		12	14	16	18
Protective height (Note 2)		470 mm $18.504$ in	550 mm $21.654$ in	630 mm $24.803$ in	710 mm $27.953$ in
	When using as safety equipment for Chinese press machine or when using SF4D-□-01 for Japanese press machine or paper shearing machine	440 mm $17.323$ in	520 mm $20.472$ in	600 mm $23.622$ in	680 mm $26.772$ in
Current consumption		Emitter: 100 mA or less, Receiver: 130 mA or less			
PFH <sub>D</sub> / MTTFD <sub>D</sub>		$1.18 \times 10^{-9}$ / 1,060 years	$1.29 \times 10^{-9}$ / 966 years	$1.36 \times 10^{-9}$ / 910 years	$1.46 \times 10^{-9}$ / 840 years
Net weight (Total of emitter and receiver)		1,100 g approx.	1,300 g approx.	1,500 g approx.	1,700 g approx.

Type		Min. sensing object $\varnothing 45$ mm $\varnothing 1.772$ in type (40 mm $1.575$ in beam pitch)			
Item	Model No.	SF4D-A20(-01)	SF4D-A24(-01)	SF4D-A28(-01)	SF4D-A32(-01)
Number of beam channels		20	24	28	32
Protective height (Note 2)		790 mm $31.102$ in	950 mm $37.402$ in	1,110 mm $43.701$ in	1,270 mm $50.000$ in
	When using as safety equipment for Chinese press machine or when using SF4D-□-01 for Japanese press machine or paper shearing machine	760 mm $29.921$ in	920 mm $36.220$ in	1,080 mm $42.520$ in	1,240 mm $48.819$ in
Current consumption		Emitter: 100 mA or less, Receiver: 130 mA or less	Emitter: 100 mA or less, Receiver: 140 mA or less		Emitter: 110 mA or less, Receiver: 140 mA or less
PFH <sub>D</sub> / MTTFD <sub>D</sub>		$1.54 \times 10^{-9}$ / 798 years	$1.71 \times 10^{-9}$ / 710 years	$1.89 \times 10^{-9}$ / 640 years	$2.07 \times 10^{-9}$ / 582 years
Net weight (Total of emitter and receiver)		1,900 g approx.	2,300 g approx.	2,800 g approx.	3,200 g approx.

Type		Min. sensing object $\varnothing 45$ mm $\varnothing 1.772$ in type (40 mm $1.575$ in beam pitch)			
Item	Model No.	SF4D-A36(-01)	SF4D-A40(-01)	SF4D-A44(-01)	SF4D-A48(-01)
Number of beam channels		36	40	44	48
Protective height (Note 2)		1,430 mm $56.299$ in	1,590 mm $62.598$ in	1,750 mm $68.898$ in	1,910 mm $75.197$ in
	When using as safety equipment for Chinese press machine or when using SF4D-□-01 for Japanese press machine or paper shearing machine	1,400 mm $55.118$ in	1,560 mm $61.417$ in	1,720 mm $67.717$ in	1,880 mm $74.016$ in
Current consumption		Emitter: 110 mA or less, Receiver: 150 mA or less			Emitter: 110 mA or less, Receiver: 160 mA or less
PFH <sub>D</sub> / MTTFD <sub>D</sub>		$2.24 \times 10^{-9}$ / 534 years	$2.42 \times 10^{-9}$ / 493 years	$2.60 \times 10^{-9}$ / 458 years	$2.77 \times 10^{-9}$ / 428 years
Net weight (Total of emitter and receiver)		3,600 g approx.	4,000 g approx.	4,400 g approx.	4,800 g approx.

Notes: 1) Where measurement conditions have not been specified precisely, the conditions used were an ambient temperature of +20 °C +68 °F.

PFH<sub>D</sub>: Probability of dangerous failure per hour, MTTFD<sub>D</sub>: Mean time to dangerous failure (in years)

- 2) In the case of "When used as safety device for presses in China" or "When SF4D-□-01 is used for presses or shearing machines (paper cutting machines) in Japan," the distance between the center of the first beam axis and the center of the last beam axis of the device becomes the protective height.



# SPECIFICATIONS

## Safety light curtain common specifications

Item	Type	Min. sensing object $\varnothing$ 14 mm $\varnothing$ 0.551 in (10 mm 0.394 in beam pitch)	Min. sensing object $\varnothing$ 25 mm $\varnothing$ 0.984 in (20 mm 0.787 in beam pitch)	Min. sensing object $\varnothing$ 45 mm $\varnothing$ 1.772 in (40 mm 1.575 in beam pitch)
	Model No.	SF4D-F□	SF4D-H□	SF4D-A□
	Japanese press machine or paper shearing machine compliant	SF4D-F□-01	SF4D-H□-01	SF4D-A□-01
Applicable standards	International standards	IEC 61496-1/2 (Type 4), ISO 13849-1: 2015 (Category 4, PL <sub>e</sub> ), IEC 61508-1 to 3 (SIL3)		
	Japan	JIS B 9704-1/2 (Type 4), JIS B 9705-1 (Category 4), JIS C 0508-1 to 3 (SIL3)		
	Europe	EN ISO 13849-1 (Category 4, PL <sub>e</sub> ), EN 55011, EN 61000-6-2, EN IEC 63000		
	North America	ANSI/UL 61496-1/2 (Type 4), CAN/CSA C22.2 No.14, CAN/CSA E61496-1/2		
	China	GB/T 4584		
Applicable regulations and certifications	CE Marking (Machinery Directive, EMC Directive, RoHS Directive), UKCA Marking [Supply of Machinery (Safety) Regulations, EMC Regulations, RoHS Regulations] TÜV SÜD certification, TÜV SÜD certification (U.S.A., Canada), OSHA 1910.212, OSHA 1910.217(C), ANSI B11.1 to B11.19, ANSI/RIA 15.06, Korea KCs mark (Note 2)			
Operating range (Note 3)	Short mode: 0.2 to 7 m 0.656 to 22.966 ft Long mode: 0.8 to 12 m 2.625 to 39.370 ft (selectable by DIP switch)		Short mode: 0.2 to 9 m 0.656 to 29.528 ft Long mode: 0.8 to 15 m 2.625 to 49.213 ft (selectable by DIP switch)	
Min. sensing object (Note 4)	$\varnothing$ 14 mm $\varnothing$ 0.551 in opaque object	$\varnothing$ 25 mm $\varnothing$ 0.984 in opaque object	$\varnothing$ 45 mm $\varnothing$ 1.772 in opaque object	
Effective aperture angle	$\pm$ 2.5° or less at a sensing range of 3 m 9.843 ft or longer (based on IEC 61496-2)			
Supply voltage	24 V DC <sup>+20</sup> <sub>-30</sub> % Ripple P-P 10 % or less (excluding voltage drop due to cable) (Note 5, 6)			
Control outputs (OSSD 1, OSSD 2)	PNP open-collector transistor / NPN open collector transistor (selectable)			
	<PNP output selected>		<NPN output selected>	
	<ul style="list-style-type: none"> <li>• Maximum source current: 350 mA</li> <li>• Applied voltage: Same as supply voltage (between control output and +V)</li> <li>• Residual voltage: 2 V or less (source current 350 mA) (excluding voltage drop due to cable)</li> <li>• Leakage current: 0.2 mA or less (including power OFF state)</li> <li>• Maximum load capacity: 2.2 <math>\mu</math>F</li> <li>• Load wiring resistance: 3 <math>\Omega</math> or less</li> </ul>		<ul style="list-style-type: none"> <li>• Maximum sink current: 350 mA</li> <li>• Applied voltage: Same as supply voltage (between control output and 0 V)</li> <li>• Residual voltage: 2 V or less (sink current 350 mA) (excluding voltage drop due to cable)</li> <li>• Leakage current: 0.2 mA or less (including power OFF state)</li> <li>• Maximum load capacity: 2.2 <math>\mu</math>F</li> <li>• Load wiring resistance: 3 <math>\Omega</math> or less</li> </ul>	
	ON when all beams are received, OFF when one or more beams are blocked (Also OFF when internal sensor error or synchronization signal error occurs) (Note 7)			
Protection circuit	Incorporated			
Response time	OFF response: 10 ms or less (Not connected in series / parallel), 18 ms or less (Connected in series / parallel) (Note 8) ON response: 50 ms or less (Note 9) (Note 10)			
Auxiliary output (AUX) (Non-safety output)	PNP open-collector transistor / NPN open collector transistor (selectable)			
	<PNP output selected>		<NPN output selected>	
	<ul style="list-style-type: none"> <li>• Maximum source current: 60 mA</li> <li>• Applied voltage: Same as supply voltage (between auxiliary output and +V)</li> <li>• Residual voltage: 2 V or less (source current 60 mA) (excluding voltage drop due to cable)</li> <li>• Leakage current: 0.2 mA or less (including power OFF state)</li> </ul>		<ul style="list-style-type: none"> <li>• Maximum sink current: 60 mA</li> <li>• Applied voltage: Same as supply voltage (between auxiliary output and 0 V)</li> <li>• Residual voltage: 2 V or less (sink current 60 mA) (excluding voltage drop due to cable)</li> <li>• Leakage current: 0.2 mA or less (including power OFF state)</li> </ul>	
	Control output ON: OFF, Control output OFF: ON (Note 7)			
Protection circuit	Incorporated			
Response time	OFF response: 60 ms or less, ON response: 60 ms or less			
Synchronization method	Line synchronization / optical synchronization (selectable by DIP switch)			
Interference prevention function	<Not connected in series/parallel> <ul style="list-style-type: none"> <li>• Line synchronization: 2 units or less (auto)</li> <li>• Optical synchronization: 2 units or less (selectable by DIP switch)</li> </ul> <Connected in series/parallel> <ul style="list-style-type: none"> <li>• Series connection: 5 units or less (total number of beam channels 256 or less)</li> <li>• Parallel connection: 3 units or less (total number of beam channels 192 or less) (Note 7)</li> <li>• Series / parallel connection mixed: 5 units or less (total number of beam channels 144 or less) (Note 7)</li> </ul>			
Test input function	Incorporated			
Interlock function	Incorporated [Manual reset / auto reset (selectable by wiring)] (8-core cable or 12-core cable)			
Lockout release function	Incorporated			
External device monitor function	Incorporated (8-core cable or 12-core cable)			
Application indicator function	Incorporated (only the receiver lights up when optical synchronization is used)			
Muting function	Incorporated (12-core cable)			
Override function	Incorporated (12-core cable)			
Power save function	Incorporated			
Optional functions (Note 11) (Excluding SF4D-□-01)	Fixed blanking function, floating blanking function, interlock setting function, external device monitoring setting function, auxiliary output setting function, application indicator setting function, muting setting function, override setting function, protect function, I/O setting function			

## SPECIFICATIONS

Item	Type	Min. sensing object $\varnothing 14$ mm $\varnothing 0.551$ in (10 mm $0.394$ in beam pitch)	Min. sensing object $\varnothing 25$ mm $\varnothing 0.984$ in (20 mm $0.787$ in beam pitch)	Min. sensing object $\varnothing 45$ mm $\varnothing 1.772$ in (40 mm $1.575$ in beam pitch)
	Model No.	<b>SF4D-F</b> $\square$	<b>SF4D-H</b> $\square$	<b>SF4D-A</b> $\square$
	Japanese press machine or paper shearing machine compliant	<b>SF4D-F</b> $\square$ -01	<b>SF4D-H</b> $\square$ -01	<b>SF4D-A</b> $\square$ -01
Pollution degree		3		
Operating altitude		2,000 m $6,561.68$ ft or less (Note 12)		
Environmental resistance	Degree of protection	IP67, IP65 (IEC), NEMA Type 13 (NEMA 250)		
	Ambient temperature	-10 to +55 °C $+14$ to $+131$ °F (No dew condensation or icing allowed), Storage: -25 to +60 °C $-13$ to $+140$ °F		
	Ambient humidity	30 to 85 % RH, Storage: 30 to 95 % RH		
	Ambient illumination	Incandescent light: 5,000 lx or less at the light-receiving surface		
	Dielectric strength voltage	1,000 V AC for one minute, between all supply terminals connected together and enclosure		
	Insulation resistance	20 M $\Omega$ , or more, with 500 V DC megger, between all supply terminals connected together and enclosure		
	Vibration resistance	10 to 55 Hz, 0.75 mm $0.030$ in double amplitude in X, Y, and Z directions for two hours each Malfunction resistance 10 to 55 Hz, 0.75 mm $0.030$ in double amplitude in X, Y, and Z directions twenty times each		
	Shock resistance	300 m/s <sup>2</sup> acceleration (30 G approx.) in X, Y, and Z directions three times each Malfunction resistance 100 m/s <sup>2</sup> acceleration (10 G approx.) in X, Y, and Z directions 1,000 times each		
SFF (Safe Failure Fraction)		99 %		
HFT (Hardware Fault Tolerance)		1		
Subsystem type		Type B (IEC 61508-2)		
T1 (proof test interval)		20 years		
Failure response time		Within response time (OFF response)		
Safety state		Control output (OSSD 1 / 2) OFF state		
Emitter element		Infrared LED (peak emission wavelength: 850 nm $0.034$ mil)		
Material		Enclosure: Aluminum, Detection surface: Polycarbonate resin and stainless steel (SUS304), Upper cap / lower cap: Nylon		
Connecting method		By connector		
Cable extension		Total length of emitter / receiver can be extended up to 70 m $229.659$ ft each using optional mating cable (including the length of cables for series connection) (Note 6)		
Accessories		<b>SF4B-TR14</b> (test rod): 1 pc.	<b>SF4B-TR25</b> (test rod): 1 pc.	_____

Notes: 1) Where measurement conditions have not been specified precisely, the conditions used were an ambient temperature of +20 °C  $+68$  °F.

- 2) Except for **SF4D- $\square$ -01**, Korea KCs mark is acquired.
- 3) The operating range is the possible setting distance between the emitter and the receiver.
- 4) When the floating blanking function is used, the size of the minimum sensing object varies. For the detail, refer to the section on **Safety distance** (p.36).
- 5) The power supply unit must satisfy the following requirements:
  - (1) The power unit must be certified for use in your region.
  - (2) Use of the product as a unit in compliance with CE Marking: SELV (safety extra low voltage) / PELV (protected extra low voltage) power supply unit in conformity with EMC Directive and Low Voltage Directive.
  - (3) Use of the product as a unit in compliance with UKCA Marking: SELV (safety extra low voltage) / PELV (protected extra low voltage) power supply unit in conformity with EMC Regulations and Low Voltage Regulations.
  - (4) When using a commercial switching regulator, the frame ground (F.G.) terminal must be connected to ground.
  - (5) The power supply unit must have an output holding time of 20 ms or more.
  - (6) If surges occur, take countermeasures such as connecting a surge absorber to the source of the surges.
  - (7) The power unit must be a CLASS 2 compliant unit. (When cTÜVus mark compliance is required.)
- 6) In consideration of the voltage drop caused by the cable, use **Control output (OSSD 1, OSSD 2) source / sink current and cable length** (p.27) as a guideline.
- 7) The setting can be changed when the **SF4D-TM1** (optional) and **Configurator Light Curtain** setting software are used. Note that the setting cannot be changed when **SF4D- $\square$ -01** is used.
- 8) For response times by number of beams, refer to the **Control output (OSSD 1, OSSD 2) OFF response times** (p.27).
- 9) Because the control output (OSSD 1, OSSD 2) must be OFF for at least 80 ms, the ON response will be delayed more than 50 ms when the light blocked time is less than 30 ms.
- 10) When optical synchronization is selected, if the beam axes of both the top end and bottom end are blocked, the ON response speed decreases by as much as 1 sec.
- 11) To use optional functions, the **SF4D-TM1** (optional) and **Configurator Light Curtain** setting software are required. Note that optional functions cannot be used when **SF4D- $\square$ -01** is used.
- 12) Do not use or store in an environment pressurized to atmospheric pressure or higher at an altitude of 0 m.

# SPECIFICATIONS

## Control output (OSSD 1, OSSD 2) source / sink current and cable length

Number of sub-sensors	Control output (OSSD 1, OSSD 2) source / sink current	Power supply cable length Length of cable for series connection (Total cable length)	Cable	
			Power supply cable length	Cable length for series connection
0 (No series connection)	100 mA	70 m 229.659 ft or less	_____	_____
	200 mA		_____	_____
	350 mA		10.5 m 34.449 ft or less	_____
1	100 mA	50 m 164.042 ft or less	_____	Cable length obtained by subtracting power supply cable length from total cable length
	200 mA		_____	
	350 mA		10.5 m 34.449 ft or less	
2	100 mA	50 m 164.042 ft or less	_____	Cable length obtained by subtracting power supply cable length from total cable length
	200 mA		_____	
	350 mA		10.5 m 34.449 ft or less	
3	100 mA	50 m 164.042 ft or less	_____	Cable length obtained by subtracting power supply cable length from total cable length
	200 mA		40.5 m 132.874 ft or less	
	350 mA		10.5 m 34.449 ft or less	
4	100 mA	25.5 m 83.661 ft or less	_____	Cable length obtained by subtracting power supply cable length from total cable length
	200 mA		20.5 m 67.257 ft or less	
	350 mA		10.5 m 34.449 ft or less	

\* Power supply cable: Cable consisting of the bottom cap cable (optional) and extension cable (optional)

## Control output (OSSD 1, OSSD 2) OFF response times

Number of units connected in series	Number of units connected in parallel	OFF response time												
		Main sensor	Sub sensor											
			1 unit	1 unit	2 units	3 units	4 units	0 units	0 units	1 unit	1 unit	2 units	2 units	3 units
Total number of beams	4 to 48	6 ms	10 ms	10 ms	12 ms	12 ms	14 ms	14 ms	14 ms	14 ms	14 ms	14 ms	14 ms	14 ms
	49 to 96	8 ms	10 ms	10 ms	12 ms	12 ms	14 ms	14 ms	14 ms	14 ms	14 ms	14 ms	14 ms	14 ms
	97 to 127	10 ms	12 ms	12 ms	14 ms	14 ms	14 ms	14 ms	14 ms	14 ms	14 ms	14 ms	14 ms	14 ms
	128 to 144	_____	12 ms	12 ms	14 ms	14 ms	14 ms	14 ms	14 ms	14 ms	14 ms	14 ms	14 ms	14 ms
	145 to 192	_____	14 ms	14 ms	16 ms	16 ms	14 ms	14 ms	_____	_____	_____	_____	_____	_____
	193 to 256	_____	16 ms	16 ms	18 ms	18 ms	_____	_____	_____	_____	_____	_____	_____	_____

• **Example of series connection**  
5 units or fewer (Total number of beam channels must be 256 or less.)

• **Example of combination of series connection and parallel connection**  
5 units or fewer (Total number of beam channels must be 144 or less.)

〈when using 1 main sensor and 2 sub-sensors〉

〈when using 1 main sensor, 2 sub-sensors connected in series and 2 sub-sensors connected in parallel〉

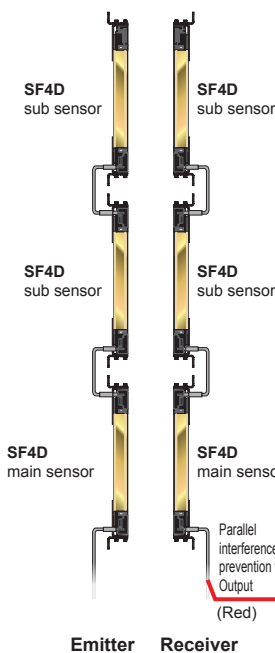
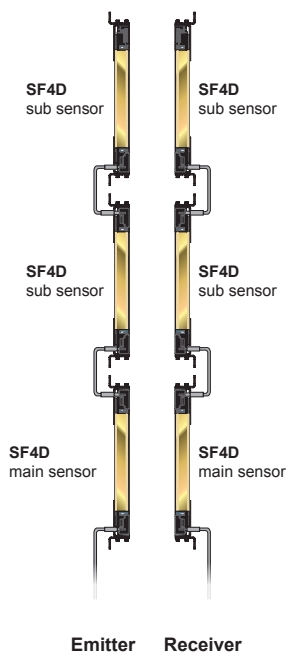

• When SF4D-□-01 is used, parallel connection or combination of series connection and parallel connection cannot be used.

• In the case of parallel connection or combination of series connection and parallel connection, it is necessary to change settings by using the SF4D-TM1 communication module (optional) and Configurator Light Curtain setting software.

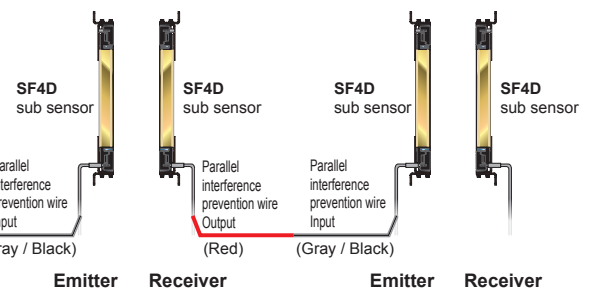

Note: Refer to the instruction manual for details.

# SPECIFICATIONS

## Control units

Product name		Safety control unit	
Item	Model No.	SF-C21	
Applicable standards	Safety	IEC 61508-1 to 3, EN 61508-1 to 3 (SIL3), ISO 13849-1: 2015 (Up to Category 4, PL <sub>e</sub> ), IEC 61131-2, IEC 61010-2-201, IEC 62061(SILCL3), UL 61010-1, UL 61010-2-201, UL 1998, KS C 9811: 2019 (EN 55011), KS C 9610-6-2: 2019 (EN 61000-6-2)	
	EMC	IEC 61000-6-2, IEC 61326-3-1, EN 55011	
Related standards		IEC 60947-1, IEC 60947-5-1, IEC 60947-5-2, IEC 60947-5-5, IEC 60947-5-8, IEC 61496-1, IEC TS 62046, ISO 13851	
Applicable regulations and certifications		CE Marking (Machinery Directive, EMC Directive, RoHS Directive), UKCA Marking [Supply of Machinery (Safety) Regulations, EMC Regulations, RoHS Regulations], TÜV SÜD certification, TÜV SÜD certification (U.S.A., Canada), Korea's Radio Waves Act conformity registration	
Supply voltage (Note 1, 2)	Power supply for internal	24 V DC $\pm 10\%$ Ripple P-P10 % or less	
	Power supply for external	24 V DC $\pm 10\%$ Ripple P-P10 % or less	
Current consumption (Note 1, 2)	Power supply for internal	200 mA or less	
	Power supply for external	100 mA or less	
Safety input (IN1 to IN8)		2 × 4 inputs, Rated voltage: Same as the voltage of the power supply for internal	
ON level / OFF level		Input voltage: 18 V, Input current: 3.5 mA / Input voltage: 5 V, Input current: 1.0 mA	
Rated input current / Input impedance		5 mA approx. / 4.7 KΩ approx.	
Duration of detectable ON state		10 ms or more	
Duration of undetectable OFF state		0.7 ms or less	
Control output (OUT1 to OUT4)		PNP open-collector transistor with 2 outputs × 2 <ul style="list-style-type: none"> <li>• Maximum source current: 300 mA / output</li> <li>• Residual voltage: 2.5 V or less</li> </ul> <ul style="list-style-type: none"> <li>• Applied voltage: Same as the voltage of the power supply for external</li> <li>• Leakage current: 100 μA or less (Including power supply OFF condition)</li> </ul>	
Output mode		True: ON, False: OFF	
ON delay function / OFF delay function		Incorporated / Incorporated	
Short-circuit protection / Response time		Incorporated / OFF response: 10 ms or less, ON response: 100 ms or less	
Auxiliary output (AUX1 to AUX4) (Non-safety output)		PNP open-collector transistor with 1 output × 4 <ul style="list-style-type: none"> <li>• Maximum source current: 60 mA / output</li> <li>• Residual voltage: 2.5 V or less</li> </ul> <ul style="list-style-type: none"> <li>• Applied voltage: Same as the voltage of the power supply for external</li> <li>• Leakage current: 100 μA or less (Including power supply OFF condition)</li> </ul>	
Output mode (Factory defaults)		AUX1: Negative logic of OUT1 / OUT2 (ON when OUT1 / OUT2 is OFF) AUX3: Reset trigger output (ON under reset release wait condition)	AUX2: Negative logic of OUT3 / OUT4 (ON when OUT3 / OUT4 is OFF) AUX4: Lockout output (OFF when lockout)
Output mode (Any of the auxiliary outputs can be customized using the software tool)		Negative logic of OUT1 / OUT2 (ON when OUT1 / OUT2 is OFF) Positive logic of OUT1 / OUT2 (ON when OUT1 / OUT2 is ON) Outputs A, B, C, and D of diagnosis results of input blocks (ON when logic is true) Reset trigger output (ON under reset release wait condition) Muting indicator output (ON when muting / override) No output (normally OFF)	Negative logic of OUT3 / OUT4 (ON when OUT3 / OUT4 is OFF) Positive logic of OUT3 / OUT4 (ON when OUT3 / OUT4 is ON) Outputs E, F, and G of internal logic circuit diagnostic results (ON when logic is true) Lockout output (OFF when lockout) Monitor output in response to IN1 to IN8 (ON when input)
Short-circuit protection / Response time		Incorporated / 10 ms or less	
Muting indicator output		Semiconductor photo MOS relay output × 1 <ul style="list-style-type: none"> <li>• Maximum load current: 60 mA</li> <li>• Residual voltage: 2.5 V or less</li> </ul> <ul style="list-style-type: none"> <li>• Supply voltage: Same as the voltage of the power supply for internal</li> <li>• Leakage current: 100 μA or less (Including power supply OFF condition)</li> </ul>	
Output mode		ON when muting / override	
Short-circuit protection / Response time		Incorporated / 10 ms or less	
Interlock function / Lockout release function		Incorporated / Incorporated	
External device monitor function		Incorporated	
Communication function (MODBUS RTU)		Interface: RS-485, Protocol: MODBUS RTU, Maximum transmission distance: 100 m <b>328.084 ft</b> , Maximum number of units that can be connected: 8 units (slaves)	
Logic selection function		No.0: Customization control No.3: Sequential muting control No.6: Two-hand control	No.1: Overall stop control No.4: Partial stop control 1 No.7: OR control
Logic setting function		Input mode, control mode, output mode, reset mode, auxiliary output mode	
Excess voltage category / Pollution degree		II / 2	
Usable altitude (Note 3)		2,000 m <b>6561.680 ft</b> or less	
Startup time after power on		2 sec. or less	
PFH <sub>D</sub> (Note 4) / MTTFD <sub>D</sub> (Note 4)		9.73 × 10 <sup>-10</sup> / 100 years or more	
Environmental resistance	Degree of protection	IP20 (IEC) (must be installed in a control panel with protection IP54 or higher)	
	Ambient temperature	-10 to +55 °C <b>+14 to +131 °F</b> (No dew condensation or icing allowed), Storage: -25 to +60 °C <b>-13 to +140 °F</b>	
	Ambient humidity	30 to 85% RH, Storage: 30 to 85% RH	
	Dielectric strength voltage	1,000 V AC for one min. (All inputs connected together - USB port, all inputs connected together - RS-485 port, USB port - RS-485 port, between all supply terminals connected together and enclosure, all outputs connected together - all input connected together, all outputs connected together - USB port, all outputs connected together - RS-485 port)	
	Insulation resistance	20 MΩ, or more, with 500 V DC megger (All inputs connected together - USB port, all inputs connected together - RS-485 port, USB port - RS-485 port, between all supply terminals connected together and enclosure, all outputs connected together - all input connected together, all outputs connected together - USB port, all outputs connected together - RS-485 port)	
	Vibration resistance	5 to 8.4 Hz frequency, 3.5 mm <b>0.138 in</b> half amplitude, 8.4 to 150 Hz frequency, Max. acceleration 9.8 m/s <sup>2</sup> (1 G), in X, Y and Z directions for two hours each (IEC / EN 60068-2-6)	
Shock resistance		147 m/s <sup>2</sup> (15 G) 11 ms in X, Y and Z directions three times each (IEC/EN 60068-2-27)	
Connection method		Input / output and power supply: Detachable spring cage terminal blocks, RS-485: Detachable spring-cage terminal block, USB: Mini-B male	
Maximum cable length		100 m <b>328.084 ft</b> or less	
Material		Main unit enclosure: Polycarbonate / ABS polymer alloy, Enclosure: Polycarbonate	
Weight		Net weight: 190 g approx., Gross weight: 320 g approx.	

- Notes: 1) "Power supply for internal" is the power supply for safety input. "Power supply for external" is the power supply for control output / auxiliary output. The power supplies for internal and external are insulated.
- 2) The power supply unit connected to this device must satisfy the conditions below.
- Output voltage within 20.4 V to 26.4 V DC (Ripple P-P: 10% or less.)
  - Power supply unit SELV (safety extra low voltage) / PELV (protected extra low voltage) conforming to the EMC Directive and Low Voltage Directive (In case CE Marking conformity is required.)
  - Power supply unit SELV (safety extra low voltage) / PELV (protected extra low voltage) conforming to the EMC Regulations and Low-voltage Regulations (In case UKCA Marking conformity is required.)
  - Power supply unit conforming to the Low Voltage Directive and with an output of 100 VA or less
  - Power supply unit with an output holding time of 20 ms or more.
  - Power supply unit corresponding to CLASS 2 (In case cTUVus Mark conformity is required.)
- 3) Do not use or store in an environment pressurized to atmospheric pressure or higher at an altitude of 0 m.
- 4) PFH<sub>D</sub>: Probability of dangerous failure per hour, MTTFD<sub>D</sub>: Mean time to dangerous failure (in years)

# SPECIFICATIONS

Product name		Connector connection control unit (Japanese press machine compliant)	Thin control unit (Japanese press machine compliant)
Item	Model No.	SF-C11	SF-C13
Connectable safety light curtains		SF4D series	Safety light curtains manufactured by our company
Applicable standards	EN 61496-1 (Type 4), EN 55011, EN ISO 13849-1: 2015 (Category 4, , PLe), IEC 61496-1 (Type 4), ISO 13849-1: 2015 (Category 4, PLe), JIS B 9704-1 (Type 4), JIS B 9705-1 (Category 4), ANSI/UL 61496-1 (Type 4), UL 1998 (Class 2)		
Applicable regulations and certifications	CE Marking (Machinery Directive, EMC Directive, RoHS Directive), UKCA Marking [Supply of Machinery (Safety) Regulations, EMC Regulations, RoHS Regulations], UL/c-UL Listing certification, TÜV SÜD certification		
Supply voltage	24 V DC $\pm$ 10 % Ripple P-P 10 % or less		
Current consumption	100 mA or less (without safety light curtain)		
Fuse rating	Built-in electronic fuse, Triggering current: 0.5 A or more, Reset after power down		
Enabling path	NO contact $\times$ 3 (13-14, 23-24, 33-34)		
Utilization	AC-15, DC-13 (IEC 60947-5-1)		
Rated operation voltage (Ue) / Rated operation current (Ie)	30 V DC / 6 A, 230 V AC / 6 A, resistive load (For inductive load, during contact protection) Min. applicable load: 10 mA (at 24 V DC) (Note 2)		30 V DC / 4 A, 230 V AC / 4 A, resistive load (For inductive load, during contact protection) Min. applicable load: 10 mA (at 24 V DC) (Note 2)
Contact material / contacts	Silver tin oxide (AgSnO), self cleaning, positively driven		
Contact resistance	100 m $\Omega$ or less (initial value)		
Contact protection fuse rating	6 A (slow blow)		4 A (slow blow)
Mechanical lifetime	10,000,000 times or more (open/close frequency of 180 times/min) (Note 3)		
Electrical lifetime	100,000 times or more (open/close frequency of 20 times/min, 230 V AC, 3 A, using resistance load) (Note 3)		
Pick-up delay (Auto reset / Manual reset)	80 ms or less / 90 ms or less		
Response time	10 ms or less		
Auxiliary output	Safety relay contact (NC contact) $\times$ 1 (41-42) (Related to enabling path)		
Rated operation voltage / current	24 V DC / 2 A, Min. applicable load: 10 mA (at 24 V DC)		
Contact protection fuse rating	2 A (slow blow)		
Semiconductor auxiliary output (AUX)	<Minus ground (Setting for PNP)> PNP open-collector transistor • Maximum source current: 60 mA • Applied voltage: same as supply voltage (between the auxiliary output and +V) • Residual voltage: 2.3 V or less (at 60 mA source current) • Leakage current: 2 mA or less	<Plus ground (Setting for NPN)> NPN open-collector transistor • Maximum sink current: 60 mA • Applied voltage: same as supply voltage (between the auxiliary output and 0V) • Residual voltage: 1.5 V or less (at 60 mA sink current) • Leakage current: 2 mA or less	PNP open-collector transistor • Maximum source current: 60 mA • Applied voltage: same as supply voltage (between the auxiliary output and +V) • Residual voltage: 2.3 V or less (at 60 mA source current) • Leakage current: 2 mA or less
	Output operation	Related to auxiliary output of safety light curtain	ON when the safety light curtain is interrupted
Indicators	Power supply (Ui)	Green LED (lights up when the power is ON)	
	Enabling path (OUT)	Green LED (lights up when the enabling contacts are closed)	
	Interlock (INTER_LOCK)	Yellow LED (lights up when the enabling contacts are opened)	
	Fault (FAULT)	Yellow LED (blinks when fault occurs)	
External relay monitor function	Incorporated		
Trailing edge function	Incorporated		
Polarity selection function (Note 4)	Incorporated (Sliding switch allows selection of plus / minus ground) Minus ground: Correspond to PNP output safety light curtain Plus ground: Correspond to NPN output safety light curtain	Incorporated (Cable connection allows selection of plus / minus ground) Minus ground: Correspond to PNP output safety light curtain Plus ground: Correspond to NPN output safety light curtain	
Excess voltage category / Pollution degree	II / 2		
Environmental resistance	Degree of protection	Enclosure: IP40, Terminal: IP20	
	Ambient temperature	-10 to +55 °C <b>+14 to +131 °F</b> (No dew condensation or icing allowed), Storage: -25 to +70 °C <b>-13 to +158 °F</b>	
	Ambient humidity	30 to 85 % RH, Storage: 30 to 95 % RH	
	Vibration resistance	Malfunction resistance 10 to 55Hz, 0.35 mm <b>0.014 in</b> double amplitude 20 times each in X, Y, and Z directions	
B10D (Note 5)	Minimum load: 20,000,000, Maximum load: 400,000		
Mission time	20 years		
Connection terminal	Detachable spring-cage terminal		Spring-cage terminal
Enclosure material	ABS		
Weight	Net weight: 320 g approx.		Net weight: 200 g approx.

- Notes: 1) Where measurement conditions have not been specified precisely, the conditions used were an ambient temperature of +20 °C **+68 °F**.  
 2) If several **SF-C11** or **SF-C13** units are being used in a line together, leave a space of 5 mm **0.197 in** or more between each unit. If the units are touching each other, reduce the rated operating current for safety output in accordance with the ambient operating temperature as shown in the graphs at right.  
 3) The life expectancy of the relay varies depending on the type of load, open / close frequency, ambient conditions and others.  
 4) Please switch the sliding switch to the PNP side for minus ground and to the NPN side for plus ground.  
 5) Mean cycle time that 10% of parts reach dangerous failure.

⟨ Dilating when SF-C11 units are mounted close together ⟩

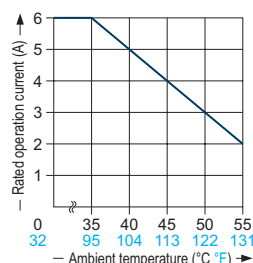

⟨ Dilating when SF-C13 units are mounted close together ⟩

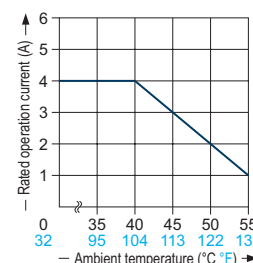

# SPECIFICATIONS

## Communication module

Model No.	SF4D-TM1
Item	
Communication system	Safety light curtain side: RS-485 bilateral communication (dedicated protocol) PC side: USB
Connection system	Safety light curtain side: Connector PC side: USB (Mini-B male)
Usable altitude	2,000 m <b>6,561.68 ft</b> or lower (Note 2)
Protection	IP40 (IEC)
Ambient temperature	-10 to +55 °C <b>+14 to +131 °F</b> (No dew condensation or icing allowed), Storage: -25 to +60 °C <b>-13 to +140 °F</b>
Ambient humidity	30 to 85% RH, Storage: 30 to 95% RH
Cable	1.5 m <b>4.921 ft</b> cable with connector (safety light curtain side) (Note 3)
Weight	Net weight: 75 g approx.

Notes: 1) Where measurement conditions have not been specified precisely, the conditions used were an ambient temperature of +20 °C **+68 °F**.  
2) Do not use or store in an environment pressurized to atmospheric pressure or higher at an altitude of 0 m.  
3) USB cable is not provided with the product. USB2.0 cable (A: Mini-B) must be prepared by the user.

## Laser alignment tool

Model No.	SF-LAT-2N
Item	
Supply voltage	3 V (LR6 battery × 2 pcs.)
Battery	1.5 V (LR6 battery) × 2 pcs. (replaceable)
Battery lifetime	30 hours approx. of continuous operation (LR6 battery, at +25 °C <b>+77 °F</b> ambient temperature)
Light source	Red semiconductor laser: Class 2 (IEC / JIS / FDA) (Max. output: 1 mW, Peak emission wavelength: 650 nm <b>0.026 mil</b> ) (Note 2)
Spot diameter	10 mm <b>0.394 in</b> approx. (at 5 m <b>16.404 ft</b> distance)
Ambient temperature	0 to +40 °C <b>+32 to +104 °F</b> (No dew condensation), Storage: 0 to +55 °C <b>+32 to +131 °F</b>
Ambient humidity	35 to 85 % RH, Storage: 35 to 85 % RH
Material	Enclosure: ABS, Mounting part: Aluminum
Weight	Net weight: 150 g approx. (Excluding batteries)

Notes: 1) Where measurement conditions have not been specified precisely, the conditions used were an ambient temperature of +20 °C **+68 °F**.  
2) This product complies with the FDA regulations (FDA 21 CFR 1040.10 and 1040.11) in accordance with FDA Laser Notice No. 56, except for complying with IEC 60825-1 Ed. 3.  
3) LR6 dry cell batteries are not provided with the product. Please purchase them separately.

## SF4D conversion adapter

Model No.	SFD-J4B (For 8-core cable) SFD-J4B-MU (For 12-core cable)
Item	
Protection	IP64 (IEC)
Ambient temperature	-10 to +55 °C <b>+14 to +131 °F</b> (No dew condensation or icing allowed), Storage: -25 to +60 °C <b>-13 to +140 °F</b>
Ambient humidity	30 to 85% RH, Storage: 30 to 95% RH
Dielectric strength voltage	1,000 V AC for one min. between all supply terminals connected together and enclosure
Insulation resistance	20 MΩ, or more, with 500 V DC megger, between all supply terminals connected together and enclosure
Vibration resistance	10 to 55 Hz, 0.75 mm <b>0.030 in</b> double amplitude in X, Y, and Z directions for two hours each Malfunction resistance 10 to 55 Hz, 0.75 mm <b>0.030 in</b> double amplitude in X, Y, and Z directions twenty times each
Shock resistance	300 m/s <sup>2</sup> acceleration (30 G approx.) in X, Y, and Z directions three times each Malfunction resistance 100 m/s <sup>2</sup> acceleration (10 G approx.) in X, Y, and Z directions 1,000 times each
Material	Enclosure: Nylon, Mounting part: Cold rolled carbon steel (SPCC)
Weight	Net weight: 270 g approx., Gross weight: 300 g approx.

Note: Where measurement conditions have not been specified precisely, the conditions used were an ambient temperature of +20 °C **+68 °F**.

## IO-Link communication unit

Model No.	SFD-WL3
Item	
Connectable safety light curtains	<b>SF4D series</b>
Applicable regulations	CE Marking (Machinery Directive, EMC Directive, RoHS Directive), UKCA Marking [Supply of Machinery (Safety) Regulations, EMC Regulations, RoHS Regulations]
Communication method	Safety light curtain communication side IO-Link communication side
Supply voltage	Safety light curtain communication side IO-Link communication side
Current consumption	Safety light curtain communication side IO-Link communication side
Functions	• IO-Link communication function • Safety light curtain setting data copy function (Note 2, 3, 4)
Number of connectable units	This product Safety light curtains in series connection
Pollution degree / Excess voltage category	3 / I
Operating altitude	2,000 m <b>6561.68 ft</b> or less (Note 5)
Environmental resistance	Protection Ambient temperature Ambient humidity Dielectric strength voltage Insulation resistance Vibration resistance Shock resistance
Material	Main unit case: PA66 (with glass), Base plate: SPCC + Plating, Product model nameplate: Polyester, External connection connector: Brass + Plating
Communication method	Safety light curtain communication side IO-Link communication side
Weight	Net weight: 270 g approx., Gross weight: 340 kg approx.

Notes: 1) Where measurement conditions have not been specified precisely, the conditions used were an ambient temperature of +20 °C **+68 °F**.  
2) This function is designed for use in maintenance and replacement of safety light curtain. If different setting information is written, the unit may not operate properly.  
3) The internal memory (nonvolatile) of this product has a service life. Settings cannot be configured more than 100,000 times.  
4) This function cannot be used unless the product is connected with the IO-Link master unit and IO-Link communication is used.  
5) Do not use or store in an environment pressurized to atmospheric pressure or higher at an altitude of 0 m.  
6) The product and IO-Link master unit must be connected with a cable of 0.3 mm<sup>2</sup> or more. The total length of the cable must not exceed 20 m **65.62 ft**.

## Corner mirror

Model No.	RF-SFBH-□
Item	
Attenuation rate of operating range	With one corner mirror: Declined to 90 %, With two corner mirrors: Declined to 80 %, With three corner mirrors: Declined to 70 % (When used in combination with the SF4D series)
Environmental resistance	Ambient temperature Ambient humidity Vibration resistance Shock resistance
Material	Enclosure: Aluminum, Mounting bracket: Stainless steel, Mirror (rear surface mirror): Glass, Side cover: EPDM
Accessories	Intermediate supporting bracket: 1 set ( <b>RF-SFBH-40/48/56/64</b> ), 2 sets ( <b>RF-SFBH-72/80/88/96</b> )

Notes: 1) Where measurement conditions have not been specified precisely, the conditions used were an ambient temperature of +20 °C **+68 °F**.  
2) The corner mirror has not received type examination by the Ministry of Health, Labour and Welfare; therefore, it cannot be used for presses or shearing machines (paper cutting machines) in Japan.

I/O circuit diagram (using optical synchronization setting and 5-core cable, Not connected in series / parallel)

<In case of using I/O circuit for PNP output>

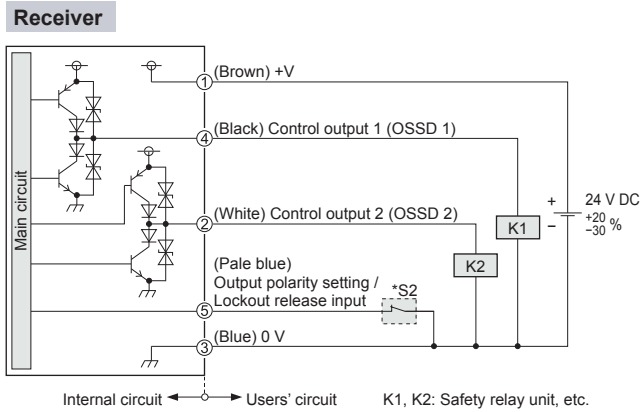
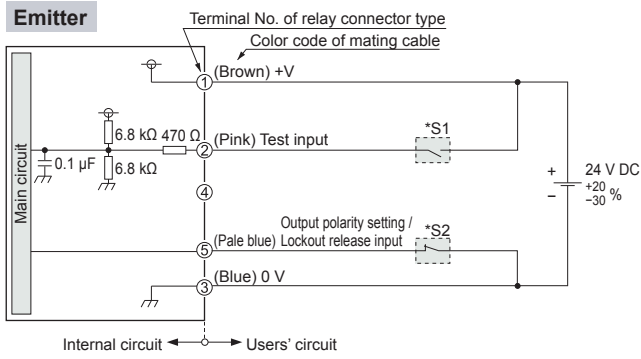

\*S1  
Switch S1  
• Test input  
Vs to Vs - 2.5 V (sink current 5 mA or less): Emission halt (Note)  
Open: Emission

\*S2  
Switch S2  
• Output polarity setting / lockout release input  
0 to +2.5 V (source current: 5 mA or less): PNP output  
Short-circuited within 150 ms to 4 s approx. after released from short-circuiting condition: Lockout release

Note: Vs is the applying supply voltage.

<In case of using I/O circuit for NPN output>

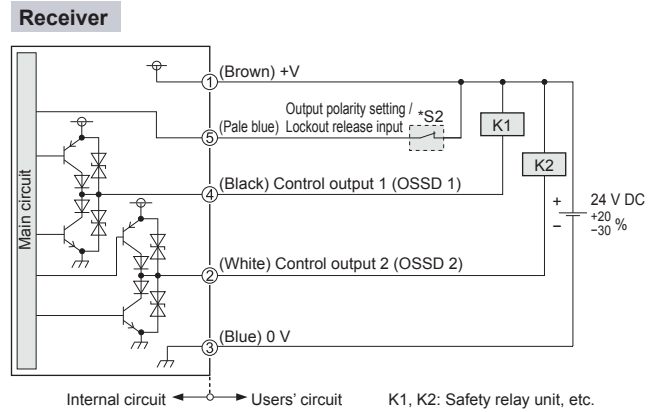
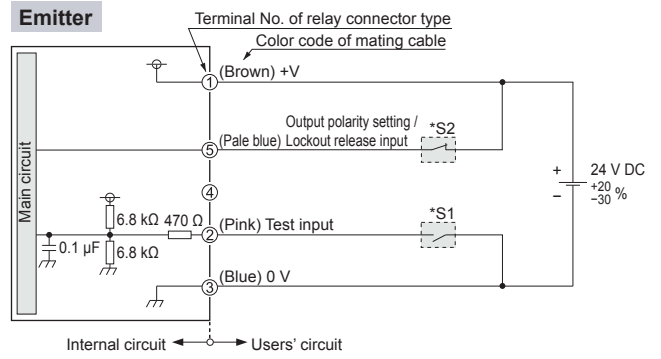

\*S1  
Switch S1  
• Test input  
0 to +2.5 V (source current 5 mA or less): Emission halt  
Open: Emission

\*S2  
Switch S2  
• Output polarity setting / lockout release input  
Vs to Vs - 2.5 V (sink current: 5 mA or less): NPN output (Note)  
Short-circuited within 150 ms to 4 s approx. after released from short-circuiting condition: Lockout release

Note: Vs is the applying supply voltage.

## I/O circuit diagram (using line synchronization setting and 8-core cable, not connected in series / parallel)

<In case of using I/O circuit for PNP output>

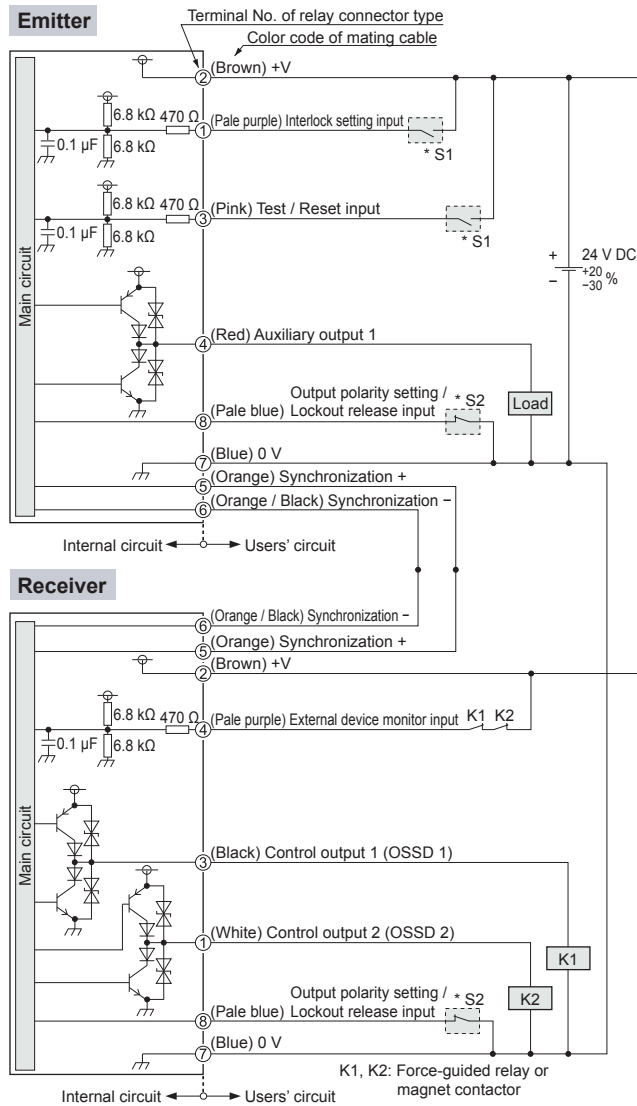

<In case of using I/O circuit for NPN output>

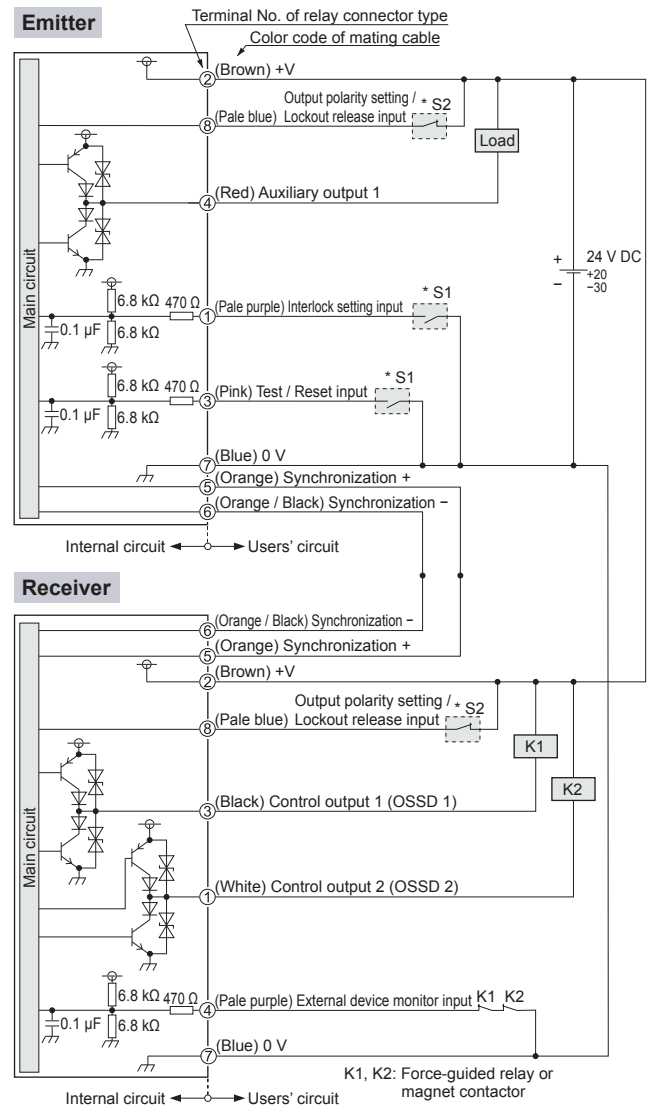

\* S1

- Switch S1**
- Test / Reset input  
<Manual reset>  
Vs to Vs - 2.5 V (sink current 5 mA or less): Emission halt (Note)  
Open: Emission  
<Auto reset>  
Vs to Vs - 2.5 V (sink current 5 mA or less): Emission (Note)  
Open: Emission halt
  - Interlock setting input  
Vs to Vs - 2.5 V (sink current 5 mA or less): Valid (Note)  
Open: Invalid

\* S2

- Switch S2**
- Output polarity setting / lockout release input  
0 to +2.5 V (source current: 5 mA or less): PNP output  
Short-circuited within 150 ms to 4 s approx. after released from short-circuiting condition: Lockout release

Note: Vs is the applying supply voltage.

\* S1

- Switch S1**
- Test / Reset input  
<Manual reset>  
0 to +2.5 V (source current 5 mA or less): Emission halt  
Open: Emission  
<Auto reset>  
0 to +2.5 V (source current 5 mA or less): Emission  
Open: Emission halt
  - Interlock setting input  
0 to +2.5 V (source current 5 mA or less): Valid  
Open: Invalid

\* S2

- Switch S2**
- Output polarity setting / lockout release input  
Vs to Vs - 2.5 V (sink current: 5 mA or less): NPN output (Note)  
Short-circuited within 150 ms to 4 s approx. after released from short-circuiting condition: Lockout release

Note: Vs is the applying supply voltage.



I/O circuit diagram (using line synchronization setting and 12-core cable, not connected in series / parallel)

<In case of using I/O circuit for PNP output>

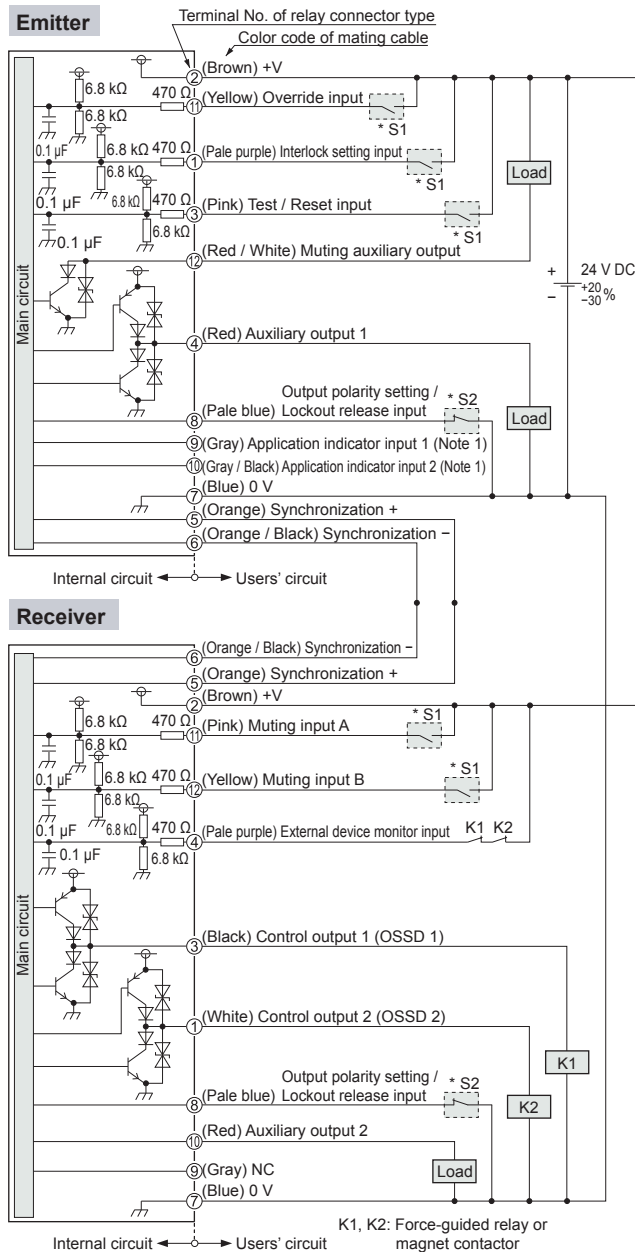

\* S1

Switch S1

- Test / Reset input  
<Manual reset>  
Vs to Vs - 2.5 V (sink current 5 mA or less): Emission halt (Note 2)  
Open: Emission  
<Auto reset>  
Vs to Vs - 2.5 V (sink current 5 mA or less): Emission (Note 2)  
Open: Emission halt
- Interlock setting input, Override input, Muting input A / B  
Vs to Vs - 2.5 V (sink current 5 mA or less): Valid (Note 2)  
Open: Invalid

\* S2

Switch S2

- Output polarity setting / lockout release input  
0 to +2.5 V (source current: 5 mA or less): PNP output  
Short-circuited within 150 ms to 4 s approx. after released from short-circuiting condition: Lockout release

Notes: 1) Vs to Vs - 2.5 V (sink current: 5 mA or less): ON (Note 2), Open: OFF  
2) Vs is the applying supply voltage.

<In case of using I/O circuit for NPN output>

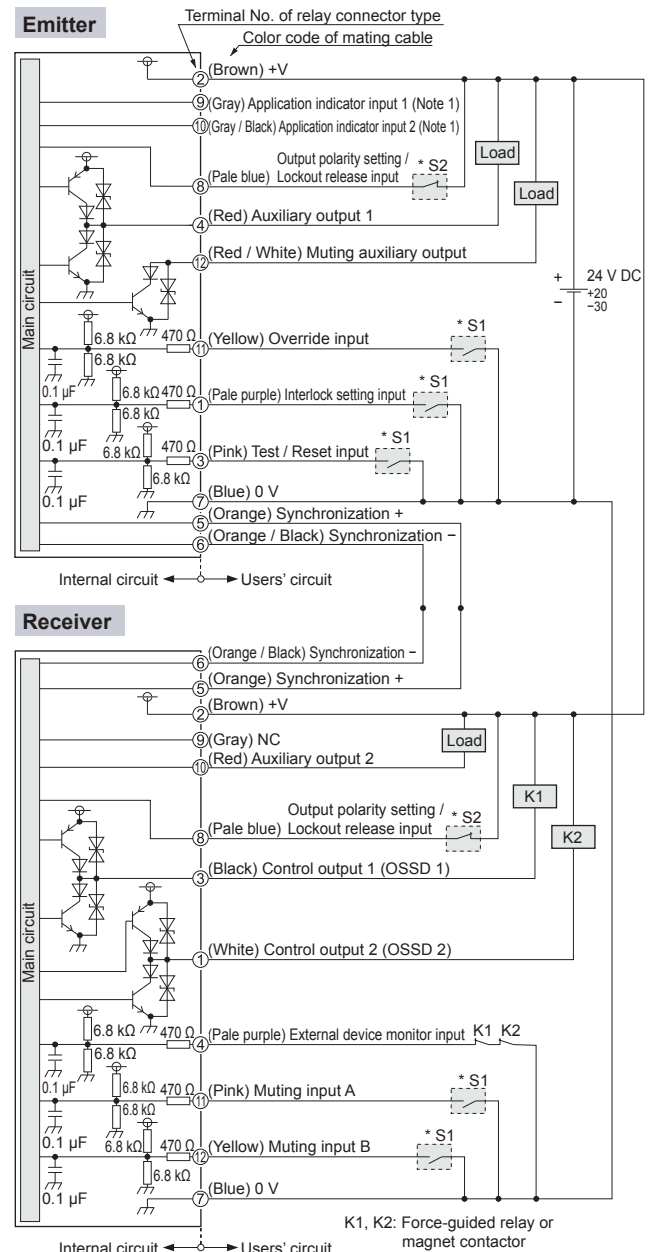

\* S1

Switch S1

- Test / Reset input  
<Manual reset>  
0 to +2.5 V (source current 5 mA or less): Emission halt  
Open: Emission  
<Auto reset>  
0 to +2.5 V (source current 5 mA or less): Emission  
Open: Emission halt
- Interlock setting input, Override input, Muting input A / B  
0 to +2.5 V (source current 5 mA or less): Valid  
Open: Invalid

\* S2

Switch S2

- Output polarity setting / lockout release input  
Vs to Vs - 2.5 V (sink current: 5 mA or less): NPN output (Note 2)  
Short-circuited within 150 ms to 4 s approx. after released from short-circuiting condition: Lockout release

Notes: 1) 0 to +2.5 V (sink current: 5 mA or less): ON, Open: OFF  
2) Vs is the applying supply voltage.

**Description and function of each part**

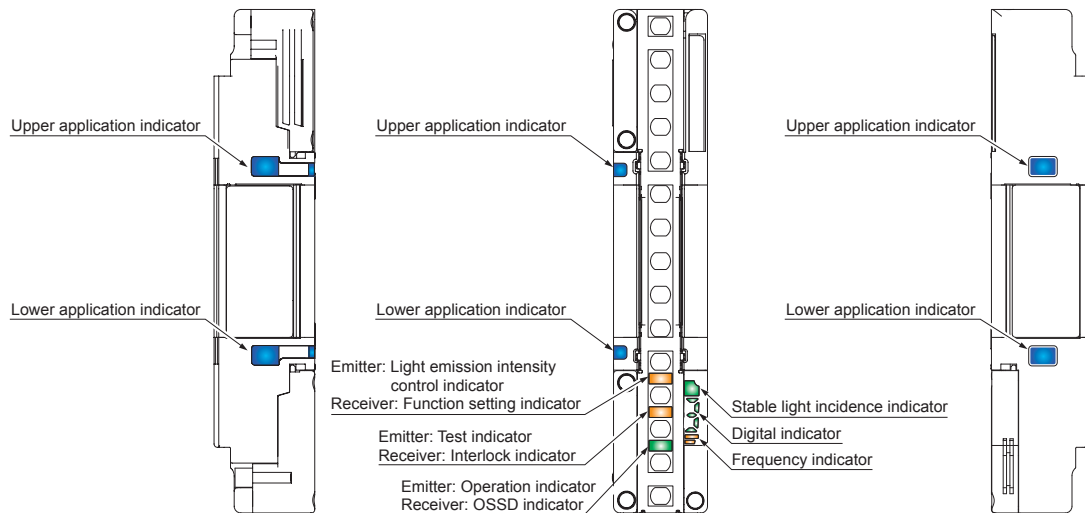

**Emitter / receiver common**

Designation		Function			
		Line synchronization		Optical synchronization	
		Receiver	Emitter	Receiver	Emitter
Upper application indicator (Blue / Green / Red / Orange)	When beam axis adjustment mode is set	All beams received [Control output (OSSD 1, OSSD 2) ON]: Lights blue Top beam received: Lights red, Top beam blocked: Turns OFF			Turns OFF
	When application mode is set	When application indicator input 1 is ON: Lights green When application indicator input 2 is ON: Lights red When application indicator input 1 / 2 are ON: Lights orange When application indicator input 1 / 2 are OFF: Turns OFF		Turns OFF	
Lower application indicator (Blue / Green / Red / Orange)	When beam axis adjustment mode is set	All beams received [Control output (OSSD 1, OSSD 2) ON]: Lights blue Bottom beam received: Lights red, Bottom beam blocked: Turns OFF			Turns OFF
	When application mode is set	When application indicator input 1 is ON: Lights green When application indicator input 2 is ON: Lights red When application indicator input 1 / 2 are ON: Lights orange When application indicator input 1 / 2 are OFF: Turns OFF		Turns OFF	
Stable light incidence indicator (Green / Orange)		When light reception is stable: Lights green When light reception is unstable: Lights orange When light is blocked: Turns OFF			Turns OFF
Digital indicator (Green / Yellow)	Light receiving intensity (Green)	Incident light level 3: Lights green "3", Incident light level 2: Lights green "2", Incident light level 1: Lights green "1", When light is blocked: Turns OFF			Turns OFF
	Error (Yellow)	Normal operation: Turns OFF, Error: Yellow number blinks or lights "E"			
	Polarity (Yellow)	When PNP output is set: Lights yellow "P" (only during startup) When NPN output is set: Lights yellow "N" (only during startup)			
Frequency indicator (Orange)		_____		When frequency 1 is set: Lights orange "1" When frequency 2 is set: Lights orange "2"	

**Emitter**

Designation (Note 1)	Function	
	Line synchronization	Optical synchronization
Light emission intensity control indicator (Orange) [CTRL]	Short mode: Turns OFF, Long mode: Lights orange	
Test indicator (Orange) [TEST]	During test: Lights orange, Normal operation: Turns OFF	
Operation indicator (Green / Red) [OP]	Control output (OSSD 1 / 2) ON: Lights green Control output (OSSD 1 / 2) OFF: Lights red	Normal operation: Lights green Error: Lights red

**Receiver**

Designation (Note 1)	Function	
	Line synchronization	Optical synchronization
Function setting indicator (Orange) [FUNC]	When communication module is connected: Blinks orange, When blanking function or parallel connection is used: Lights orange (Note 2)	
Interlock indicator (Yellow) [LOCK]	Interlock activated: Lights yellow, All other times: Turns OFF	
OSSD indicator (Green / Red) [OSSD]	Control output (OSSD 1 / 2) ON: Lights green Control output (OSSD 1 / 2) OFF: Lights red	

Notes: 1) Designations in brackets [ ] are names that are indicated on the device.  
2) For the details of blanking function and parallel connection, refer to the instruction manual.



- When this device is used in the “PSDI mode”, an appropriate control circuit must be configured between this device and the machinery. For details, be sure to refer to the standards or regulations applicable in each region or country.
- Do not use **SF4D-□** as a safety device for a press in Japan. For presses and shearing machines (paper cutting machines) in Japan, use **SF4D-□-01**.
- Do not use **SF4D-□-01** as a safety device for a press in South Korea.
- To use this product in the U.S.A., refer to OSHA 1910. 212 and OSHA 1910. 217 for installation, and in Europe, refer to EN ISO 13855 as well. Observe your national and local requirements before installing this product.

- This catalog is a guide to select a suitable product. Be sure to read instruction manual of the product prior to its use.

- Make sure to carry out the test run before regular operation.
- This safety system is for use only on machinery in which the dangerous parts can be stopped immediately, either by an emergency stop unit or by disconnecting the power supply. Do not use this system with machinery which cannot be stopped at any point in its operation cycle.

**When using SF4D-□-01 as a safety device for a press or shearing machine (paper cutting machine) in Japan**



- Abide by the Standards for Power Press Structures, the Standards for the Structures of Safety Devices for Presses or Shearing Machines (Paper Cutting Machines) and the Guidelines on Management of Safety Devices for Presses announced by the Japanese Ministry of Health, Labour and Welfare.
- Be sure to install the protective tube, **SFPD-A10** (tube length: 10 m **32.808 ft**) (optional), to the cables.

**About machines for which SF4D-□-01 is used**

- When using **SF4D-□-01** as a safety device for a press or shearing machine (paper cutting machine) in Japan, make sure that the press or shearing machine (paper cutting machine) satisfies the following specification requirements. Do not use **SF4D-□-01** if the machine does not meet the specification requirements.

**Press machine**

Item	Specifications
Machine type	Press equipped with immediate stopping mechanism and restart prevention mechanism
Pressing capacity	50,000 kN or less
Immediate stopping time	500 ms or less
Stroke length	Within (Protective height – Die height)
Die size	Within bolster width

**Shearing machine (paper cutting machine)**

Item	Specifications
Machine type	Shearing machine (paper cutting machine) equipped with immediate stopping mechanism and restart prevention mechanism
Cutting thickness	200 mm <b>7.874 in</b> or less
Cutting width	5,000 mm <b>196.850 in</b> or less
Cutter length	5,500 mm <b>216.535 in</b> or less

**Others**

- This device has been developed / produced for industrial use only.
- This product is suitable for indoor use only.
- Do not use during the initial transient time (2 sec.) after the power supply is switched on.
- Avoid dust, dirt and steam.
- Take care that the safety light curtain does not come in direct contact with water, oil, grease, or organic solvents, such as, thinner, etc.
- Take care that the safety light curtain is not directly exposed to fluorescent light from a rapid-starter lamp or a high frequency lighting device, as it may affect the sensing performance.
- Do not use this device with mobile equipment such as an automated guided vehicle (AGV).

**Communication module**



The use of the communication module, **SF4D-TM1** (optional), enables setting of various functions of the device. (Note that settings cannot be changed when **SF4D-□-01** is used.)

Details related to the safety distance, such as the minimum size of detectable objects, varies for some of the functions. When making individual settings, calculate the safety distance and provide a space greater than the safety distance when setting up the device. Unless a sufficient space is provided, the machine will not stop before the dangerous parts of the machine is touched and death or serious injury can occur.

- For the details of function settings made using the **SF4D-TM1** communication module (optional), see the manual for the communication module.

**Corner mirror**



- The corner mirror has not received type examination by the Ministry of Health, Labour and Welfare; therefore, it cannot be used for presses or shearing machines (paper cutting machines) in Japan.
- Be sure to carry out maintenance while referring to the instruction manual for the safety light curtain **SF4D** series.
- Do not use if dirt, water, or oil, etc. is attached to the reflective surface of this product. Appropriate sensing range may not be maintained due to diffusion or refraction.
- Make sure that you have read the instruction manual for the corner mirror thoroughly before setting up the corner mirrors and safety light curtains, and follow the instructions given. If the equipment is not set up correctly as stipulated in the instruction manual, incident light errors may result in unexpected situations which may result in serious injury or death.
- Please download the instruction manuals from our website.
- Safety light curtain **SF4D** series cannot be used as a retroreflective type. Avoid installing the safety light curtain as a retroreflective type when this product is applied.
- The mirror part of this product is made of glass. Note that if it is broken, the glass shards may fly apart.
- Do not use if crack or breakage appears on the reflective surface of this product. Proper sensing range may not be maintained due to diffusion or refraction. If crack or breakage appears on the reflective surface of this product, replace the product.
- When adjusting beam channels with a laser alignment tool, etc., take sufficient care that the laser beam reflected by this product does not enter the eyes.
- Failure to follow the above items may result in death or serious injury.

**IO-Link communication unit**



- Do not use the IO-Link data for safety control.
- This product cannot be used to directly enter settings from the IO-Link master unit to a safety light curtain using IO-Link communication.
- Safety light curtain setting information copy function is a function assuming maintenance of safety light curtain. Please use only when writing the safety light curtain before replacement to the light curtain after replacement. If you write to non-replacement parts, it may not operate properly.

**Sensing area**



- Make sure to install this product such that any part of the human body must pass through its sensing area in order to reach the dangerous parts of the machinery. If the human body is not detected, there is a danger of serious injury or death.
- Do not use any reflective type or retroreflective type arrangement.
- Multiple receivers (emitters) cannot be connected for use with a single emitter (receiver).

**Example of correct sensing area setup**

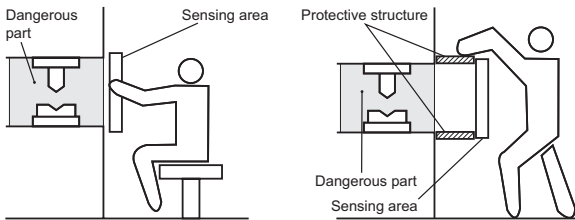

**Example of incorrect sensing area setup**

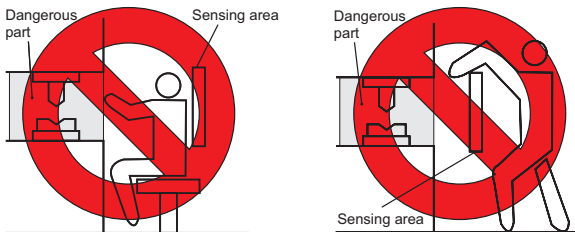

**Safety distance**



- Calculate the safety distance correctly, and always maintain a distance which is equal to or greater than the safety distance, between the sensing area of this safety light curtain and the dangerous parts of the machinery. (Please check the latest standards for the equation.) If the safety distance is miscalculated or if sufficient distance is not maintained, there is a danger of serious injury or death.
- Before designing the system, refer to the relevant standards of the region where this device is to be used and then install this device.

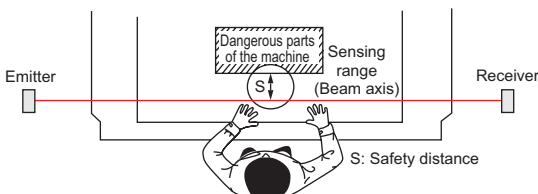

The sizes of the minimum sensing objects for this device vary depending on whether or not the floating blanking function is being used. Calculate the safety distance with the proper size of the minimum sensing object and appropriate equation.

Size of minimum sensing object when applying floating blanking function

	Min. sensing object when applying floating blanking function					
	Not set	Setting (Note)				
		1 beam channel	2 beam channels	3 beam channels	4 beam channels	5 beam channels
SF4D-F□	ø14 mm ø0.551 in	ø24 mm ø0.945 in	ø34 mm ø1.339 in	ø44 mm ø1.732 in	ø54 mm ø2.126 in	ø64 mm ø2.520 in
SF4D-H□	ø25 mm ø0.984 in	ø45 mm ø1.772 in	ø65 mm ø2.559 in	ø85 mm ø3.346 in	ø105 mm ø4.134 in	ø125 mm ø4.921 in
SF4D-A□	ø45 mm ø1.772 in	ø85 mm ø3.346 in	ø125 mm ø4.921 in	ø165 mm ø6.496 in	ø205 mm ø8.071 in	ø245 mm ø9.646 in

Note: When SF4D-□-01 is used, the floating blanking function cannot be used.

- The safety distance is calculated using the equations given on the following pages when a person moves perpendicularly (normal intrusion) into the sensing area of the device. If the intrusion direction is not perpendicular, always check the related standards (regional, machine standards, etc.)

**For use based on EN ISO 13855 / ISO 13855 / JIS B 9715**

**For intrusion perpendicular to the sensing area**

<When the minimum sensing object is ø40 mm ø1.575 in or less>

- Equation (1)  $S = K \times T + C$   
 S: Safety distance (mm)  
 Minimum required distance between the sensing area plane and the dangerous part of the machine  
 K: Intrusion speed of person or object (mm/sec.)  
 Normally 2,000 (mm/sec.) is used.  
 T: Response time of overall system  
 $T = T_m + T_{SF4D}$   
 T<sub>m</sub>: Maximum response time of machine (sec.)  
 T<sub>SF4D</sub>: Response time of device (sec.)  
 C: Additional distance calculated from the minimum sensing object of the device (mm)  
 The value of C cannot be less than 0.  
 $C = 8 \times (d - 14)$   
 d: Diameter of minimum sensing object (mm)

- When calculating the safety distance S, the following five cases must be considered. First calculate using K = 2,000 (mm/sec.) in the above equation. Consider these three cases for the result: 1) S < 100, 2) 100 ≤ S ≤ 500, and 3) S > 500. If the result of the calculation is 3) S > 500, calculate again using K = 1,600 (mm/sec.). Consider these two cases for the result: 4) S ≤ 500 and 5) S > 500. For details, refer to the manual.
- When the device is used in "PSDI mode", an appropriate safety distance S must be calculated. For details, refer to the standards and regulations that apply in your region or country.





<When the minimum sensing object is greater than ø40 mm ø1.575 in>

- Equation  $S = K \times T + C$   
 S: Safety distance (mm)  
 Minimum required distance between the sensing area plane and the nearest dangerous part of the machine  
 K: Intrusion speed of person or object (mm/sec.)  
 Normally 1,600 (mm/sec.) is used.  
 T: Overall response time of system  
 $T = T_m + T_{SF4D}$   
 T<sub>m</sub>: Maximum response time of machine (sec.)  
 T<sub>SF4D</sub>: Response time of device (sec.)  
 C: Additional distance calculated from the minimum sensing object of the device (mm)  
 $C = 850$  (mm) (Constant)







**Error display of digital indicator**

- If an error occurs, check the cause of the problem and take appropriate corrective action according to the following tables. Refer to the instruction manual for details.













**Emitter / receiver common**

Error display / Cause		Remedy
 lights. Error in device settings.	Error in settings.	Check the noise environment of the device. <b>&lt;Using SF4D-F□/H□/A□&gt;</b> • If you used the communication module <b>SF4D-TM1</b> (optional) and <b>Configurator Light Curtain</b> software, initialize the function.
	Internal failure	Contact our office.
 blinks. Series connection error, error in total number of beam channels	The number of sensors in series connection exceeds the specified limit.	Limit the number of sensors in series connection to 5 or less.
	The total number of beam channels of the sensors in series connection exceeds the specified limit.	Limit the total number of beam channels to 256 or less.
	Incorrect emitter and receiver connection when connected in a series connection.	Connect emitters to emitters and receivers to receivers using a series connection cable.
	In a series connection, the DIP switches 1 / 2 (synchronization method) are not all set to the same state.	Set all DIP switches 1 / 2 (synchronization method) to the same state.
	End cap is not attached.	Make sure the end cap is installed correctly.
	Cable for series connection is disconnected.	• Make sure the series connection cable is connected correctly. • Replace the series connection cable.
	Another error has generated.	Check the operation of other sensors in series connection.
 blinks. Error in wiring of output polarity setting / lockout release input wire (pale blue).	Output polarity setting / lockout release input wire (pale blue) is broken or shorted to another input / output wire. Incorrect connection of output polarity setting / lockout release input wire (pale blue) on receiver side of emitter / receiver.	<b>&lt;Using PNP output&gt;</b> • Connect the output polarity setting / lockout release input wire (pale blue) to 0 V (blue). <b>&lt;Using NPN output&gt;</b> • Connect the output polarity setting / lockout release input wire (pale blue) to + V (brown).
	 blinks. Power supply voltage error	The voltage of the power supplied to the device exceeds the specified range.

**Emitter**

Error display / Cause		Remedy	
 blinks. Error in the number of beam channels	The device is affected by noise or the power supply.	<ul style="list-style-type: none"> <li>• Check the noise environment of the device.</li> <li>• Check the connections, supply voltage, and power supply capacity.</li> <li>• Replace the device.</li> </ul>	
	An internal circuit has failed.		
 blinks. Emitter and receiver system mismatch.	The emitter system and receiver system do not match.	<ul style="list-style-type: none"> <li>• Make sure the beam pitch, number of sensors and number of beam channels of the emitter and receiver match.</li> <li>• Connect the output polarity setting / lockout release input wires (pale blue) of the emitter and receiver in the same way.                             <ul style="list-style-type: none"> <li>• Using PNP output: Connect to 0 V (blue)</li> <li>• Using NPN output: Connect to + V (brown)</li> </ul> </li> </ul>	
	Output is shorted to another input / output wire.		
 blinks. Muting auxiliary output error	Excessive rush current in the muting auxiliary output.	Use the muting auxiliary output at a current from 250 mA or less.	
	Output circuit error.	Output circuit damage. Replace the device.	
	Mismatch between synchronization method and wiring.	The wiring and synchronization method (line synchronization, optical synchronization) must be made to match.	
 lights. Synchronization error	Line synchronization	Synchronization + wire (orange) or synchronization - wire (orange / black) is shorted or broken.	Make sure that the synchronization + wire (orange) and synchronization - wire (orange / black) are connected correctly.
		The receiver has generated an error.	Check the operation of the receiver.
	Optical synchronization	Significant noise outside the specified range is being received.	Check the noise environment of the device.
		Cable for series connection has failed.	Replace the cable for series connection.
 blinks. Emitter error	The other emitter connected in series is locked out.	Check the digital indicator (yellow) of the other emitter connected in series.	
 blinks. Effects of noise or power supply, or internal circuit failure.	The device is affected by noise or the power supply.	<ul style="list-style-type: none"> <li>• Check the noise environment of the device.</li> <li>• Check the connections, supply voltage, and power supply capacity.</li> <li>• If you are extending the synchronization + wire (orange) and synchronization - wire (orange / black) using a cable other than the special-use cable, use a 0.2mm<sup>2</sup> or more twisted pair cable.</li> <li>• If the problem persists, check the number that is blinking in the digital indicator (yellow) and the number of times it blinks, and contact our office.</li> </ul>	
	An internal circuit has failed.		
 blinks. Synchronization error	Receiver is in lockout state.	Check an digital indicator (yellow) of receiver.	

**Receiver**

Error display / Cause		Remedy	
 blinks. Error in device settings.	Line synchronization	The device is affected by noise or the power supply. An internal circuit has failed. <ul style="list-style-type: none"> <li>• Check the noise environment of the device.</li> <li>• Check the connections, supply voltage, and power supply capacity.</li> <li>• Replace the device.</li> </ul>	
	Optical synchronization	Scattered light is received, or light emitted from a different model is received. <ul style="list-style-type: none"> <li>• Make sure that the receiver will not receive scattered light at the time of power ON.</li> <li>• Light from a different model set to the same frequency may be received. Change the setting of the DIP switches 1/2 to a different frequency.</li> </ul>	
 blinks. Emitter and receiver system mismatch.	The emitter system and receiver system do not match.	<ul style="list-style-type: none"> <li>• Make sure the beam pitch, number of sensors and number of beam channels of the emitter and receiver match.</li> <li>• Wire the output polarity setting / lockout release input wire (pale blue) of the emitter and the receiver in the same way.                             <ul style="list-style-type: none"> <li>• Using PNP output: Connect to 0V (blue)</li> <li>• Using NPN output: Connect to +V (brown)</li> </ul> </li> </ul>	
 blinks. Scattered light error.	Scattered light is received, or light emitted from a different model No. is received.	After turning on the power, make sure that the receiver does not receive scattered light.	
 or  blinks. Control output (OSSD 1 / 2) error.	The control output 1 (OSSD 1) wire (black) or the control output 2 (OSSD 2) wire (white) is shorted to 0V or +V.	Connect the control output 1 (OSSD 1) wire (black) and the control output 2 (OSSD 2) wire (white) to the safety relay unit, external device (forcible guide relay or magnetic contactor), safety controller, or safety PLC. The current values of the control output 1 (OSSD 1) wire (black) and the control output 2 (OSSD 2) wire (white) must be within the specified range.	
	The control output 1 (OSSD 1) wire (black) and control output 2 (OSSD 2) wire (white) are shorted to each other, or to another input / output wire.		
	Excessive current is flowing in the control output 1 (OSSD 1) wire (black) or control output 2 (OSSD 2) wire (white).		
 or  blinks. Control output (OSSD 1 / 2) error.	The output polarity setting / lockout release input wire (pale blue), and the control output 1 (OSSD 1) wire (black) and control output 2 (OSSD 2) wire (white) are not connected correctly.	<b>&lt;Using PNP output&gt;</b> <ul style="list-style-type: none"> <li>• Connect the output polarity setting / lockout release input wire (pale blue) to 0V (blue).</li> <li>• Connect the control output 1 (OSSD 1) wire (black) and the control output 2 (OSSD 2) wire (white) to the safety relay unit, external device (forcible guide relay or magnetic contactor), safety controller, or safety PLC.</li> </ul> <b>&lt;Using NPN output&gt;</b> <ul style="list-style-type: none"> <li>• Connect the output polarity setting / lockout release input wire (pale blue) to +V (brown).</li> <li>• Connect the control output 1 (OSSD 1) wire (black) and the control output 2 (OSSD 2) wire (white) to the safety relay unit, external device (forcible guide relay or magnetic contactor), safety controller, or safety PLC.</li> </ul>	
	Output circuit error.	Output circuit damage. Replace the device.	
 blinks. External device error.	When a safety relay is used	The safety relay contact has welded.	Replace the safety relay.
		The response time of the relay is slow.	Replace with a safety relay with a suitable response time.
		Safety relay contact "b" is not connected.	Correctly connect the safety relay. <b>&lt;Using SF4D-F□/H□/A□&gt;</b> <ul style="list-style-type: none"> <li>• This can also be set using the communication module <b>SF4D-TM1</b> (optional) and <b>Configurator Light Curtain</b> software.</li> </ul>
	When the external device monitor function is invalid.	The auxiliary output wire (red) and external device monitor input wire (pale purple) are not connected.	<ul style="list-style-type: none"> <li>• Connect the auxiliary output wire (red) and external device monitor input wire (pale purple).</li> </ul> <b>&lt;Using SF4D-F□/H□/A□&gt;</b> <ul style="list-style-type: none"> <li>• Using the communication module <b>SF4D-TM1</b> (optional) and <b>Configurator Light Curtain</b> software, set the external device monitor function to "Not used".</li> </ul>
Auxiliary output does not operate correctly.		<ul style="list-style-type: none"> <li>• Check if the auxiliary output wire (red) is broken or has shorted.</li> </ul> <b>&lt;Using SF4D-F□/H□/A□&gt;</b> <ul style="list-style-type: none"> <li>• Using the communication module <b>SF4D-TM1</b> (optional) and <b>Configurator Light Curtain</b> software, return the auxiliary output setting to the factory default setting (mode 0).</li> </ul>	
 lights. Synchronization error	Mismatch between synchronization method and wiring.		The wiring and synchronization method (line synchronization, optical synchronization) must be made to match.
	Line synchronization	Synchronization + wire (orange) or synchronization - wire (orange / black) is shorted or broken.	Make sure that the synchronization + wire (orange) and synchronization - wire (orange / black) are connected correctly.
		The emitter has generated an error.	Check the operation of the emitter.
	Optical synchronization	Significant noise outside the specified range is being received.	Check the noise environment of the device.
Cable for series connection has failed.		Replace the cable for series connection.	
 blinks. Emitter error	Emitter is in lockout state.	Check a digital indicator (yellow) of emitter.	
 blinks. Effects of noise or power supply, or internal circuit failure.	The device is affected by noise or the power supply. An internal circuit has failed.	<ul style="list-style-type: none"> <li>• Check the noise environment of the device.</li> <li>• Check the connections, supply voltage, and power supply capacity, and check for scattered light.</li> <li>• If you are extending the synchronization + wire (orange) and synchronization - wire (orange / black) using a cable other than the special-use cable, use a 0.2mm<sup>2</sup> or more twisted pair cable.</li> <li>• If the problem persists, check the number that is blinking in the digital indicator (yellow) and the number of times it blinks, and contact our office.</li> </ul>	
 blinks. Synchronization error	The other receiver connected in series is locked out.	Check the digital indicator (yellow) of the other receiver connected in series.	

**SF4D-□(-01)**

**Safety light curtain**

**Assembly dimensions**

Mounting drawing for the safety light curtains using the beam adjustment mounting bracket **MS-SFD-1-5** (optional) and the intermediate support brackets **MS-SFB-2** (optional).

**<Rear mounting>**

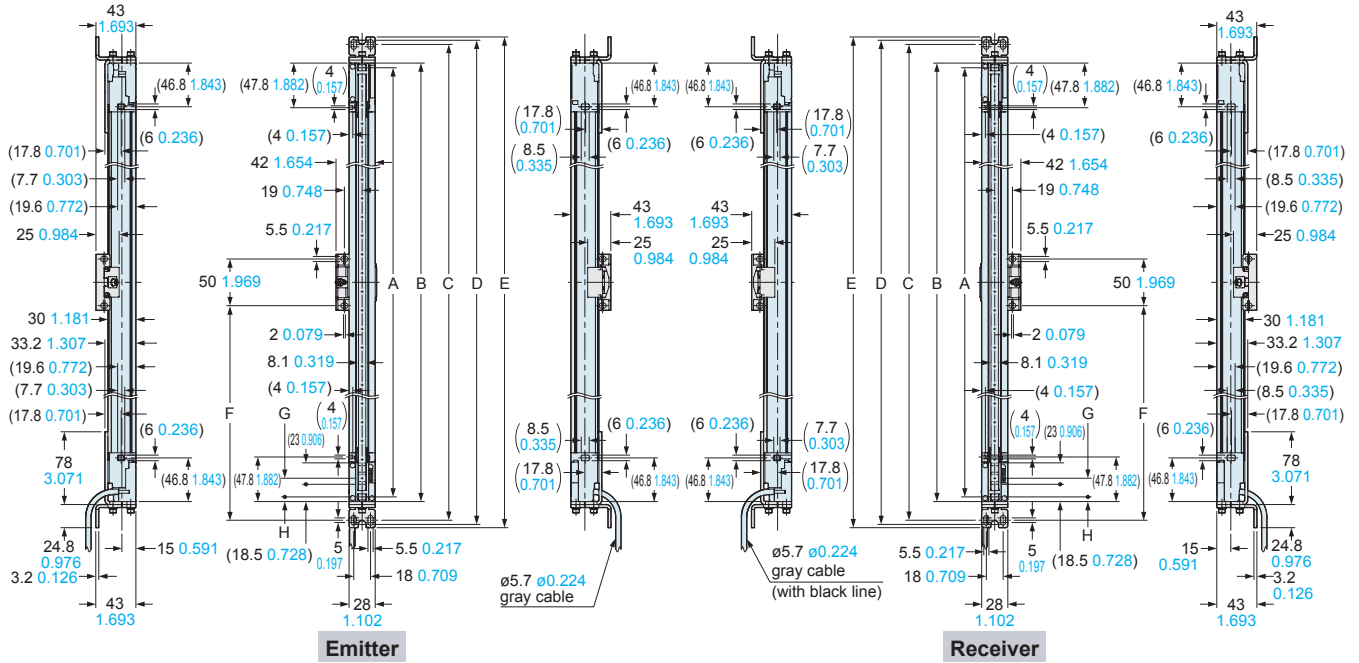

**<Side mounting>**

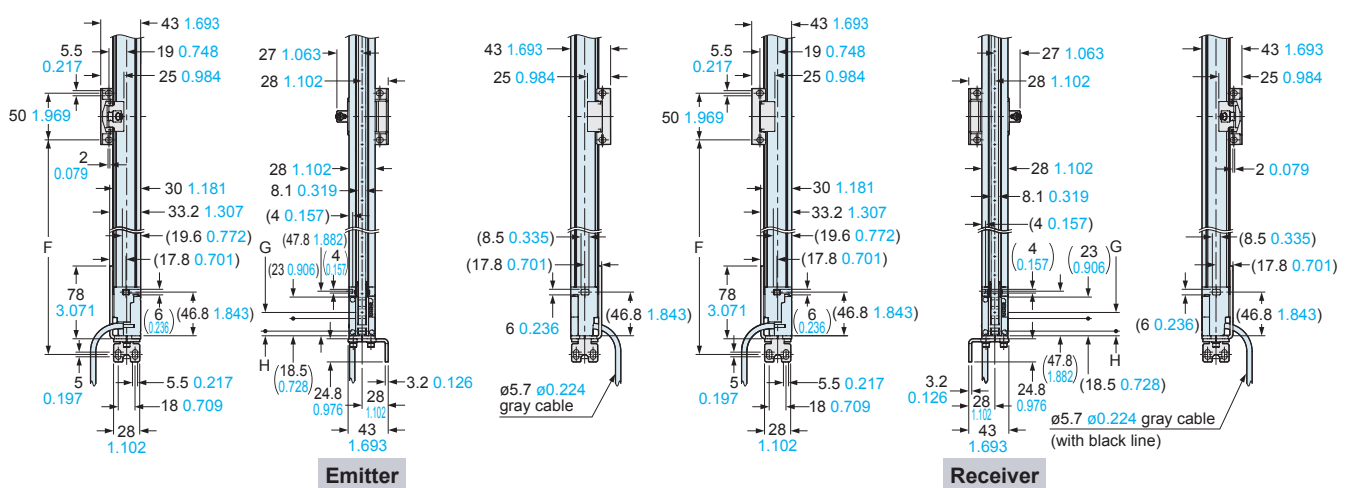

Model No.	Protective height			Mounting pitch		Total length	Intermediate support bracket mounting pitch (Note 4)		
	A (Note 1)		B	C (Note 2)	D (Note 3)				
	SF4D-F□(-01)	SF4D-A□(-01)						E	F
SF4D-F15(-01)	SF4D-H8(-01)	SF4D-A4(-01)	140 5.512	120 4.724	150 5.906	190 7.480	199 7.835	206 8.110	—
SF4D-F23(-01)	SF4D-H12(-01)	SF4D-A6(-01)	220 8.661	200 7.874	230 9.055	270 10.630	279 10.984	286 11.260	—
SF4D-F31(-01)	SF4D-H16(-01)	SF4D-A8(-01)	300 11.811	280 11.024	310 12.205	350 13.780	359 14.134	366 14.409	—
SF4D-F39(-01)	SF4D-H20(-01)	SF4D-A10(-01)	380 14.961	360 14.173	390 15.354	430 16.929	439 17.283	446 17.559	—
SF4D-F47(-01)	SF4D-H24(-01)	SF4D-A12(-01)	460 18.110	440 17.323	470 18.504	510 20.079	519 20.433	526 20.709	—
SF4D-F55(-01)	SF4D-H28(-01)	SF4D-A14(-01)	540 21.260	520 20.472	550 21.654	590 23.228	599 23.583	606 23.858	—
SF4D-F63(-01)	SF4D-H32(-01)	SF4D-A16(-01)	620 24.409	600 23.622	630 24.803	670 26.378	679 26.732	686 27.008	—
SF4D-F71(-01)	SF4D-H36(-01)	SF4D-A18(-01)	700 27.559	680 26.772	710 27.953	750 29.528	759 29.882	766 30.157	—
SF4D-F79(-01)	SF4D-H40(-01)	SF4D-A20(-01)	780 30.709	760 29.921	790 31.102	830 32.677	839 33.031	846 33.307	—
SF4D-F95(-01)	SF4D-H48(-01)	SF4D-A24(-01)	940 37.008	920 36.220	950 37.402	990 39.976	999 39.331	1,006 39.606	—
SF4D-F111(-01)	SF4D-H56(-01)	SF4D-A28(-01)	1,100 43.307	1,080 42.520	1,110 43.701	1,150 45.276	1,159 45.630	1,166 45.906	550 21.654
SF4D-F127(-01)	SF4D-H64(-01)	SF4D-A32(-01)	1,260 49.606	1,240 48.819	1,270 50.000	1,310 51.575	1,319 51.929	1,326 52.205	630 24.803
—	SF4D-H72(-01)	SF4D-A36(-01)	1,420 55.906	1,400 55.118	1,430 56.299	1,470 57.874	1,479 58.228	1,486 58.504	710 27.953
—	SF4D-H80(-01)	SF4D-A40(-01)	1,580 62.205	1,560 61.417	1,590 62.598	1,630 64.173	1,639 64.528	1,646 64.803	790 31.102
—	SF4D-H88(-01)	SF4D-A44(-01)	1,740 68.504	1,720 67.717	1,750 68.898	1,790 70.472	1,799 70.827	1,806 71.102	870 34.252
—	SF4D-H96(-01)	SF4D-A48(-01)	1,900 74.803	1,880 74.016	1,910 75.197	1,950 76.772	1,959 77.126	1,966 77.402	950 37.402

Model No.	Beam pitch	First beam channel position
	G	H
SF4D-F□(-01)	10 0.394	5 0.197
SF4D-H□(-01)	20 0.787	5 0.197
SF4D-A□(-01)	40 1.575	15 0.591

Notes: 1) In the case of "When used as safety device for presses in China" or "When SF4D-□-01 is used for presses or shearing machines (paper cutting machines) in Japan," the distance between the center of the first beam axis and the center of the last beam axis of the device becomes the protective height (A).  
 2) Mounting pitch when beam adjustment mounting bracket **MS-SFD-1-5** (optional) is mounted with two M5 hexagon-socket head bolts.  
 3) Mounting pitch when beam adjustment mounting bracket **MS-SFD-1-5** (optional) is mounted with one M8 hexagon-socket head bolt.  
 4) When the number of beam channels is **SF4D-F□(-01)**: 111 or more beam channels, **SF4D-H□(-01)**: 56 or more beam channels, **SF4D-A□(-01)**: 28 or more beam channels, one set is required.

**SF4D-□(-01)**

Safety light curtain

**Assembly dimensions**

Mounting drawing for the safety light curtains using the beam adjustment mounting bracket **MS-SFD-1-6** (optional) and the intermediate support brackets **MS-SFB-2** (optional).

**<Rear mounting>**

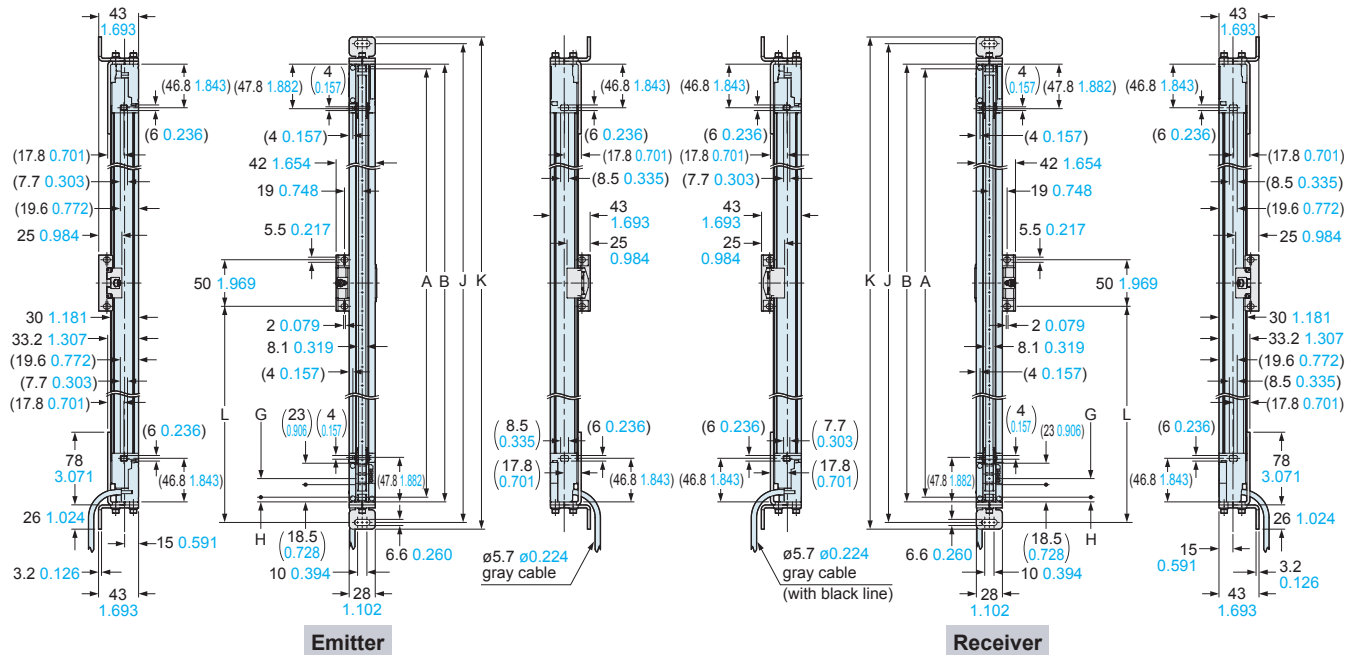

**<Side mounting>**

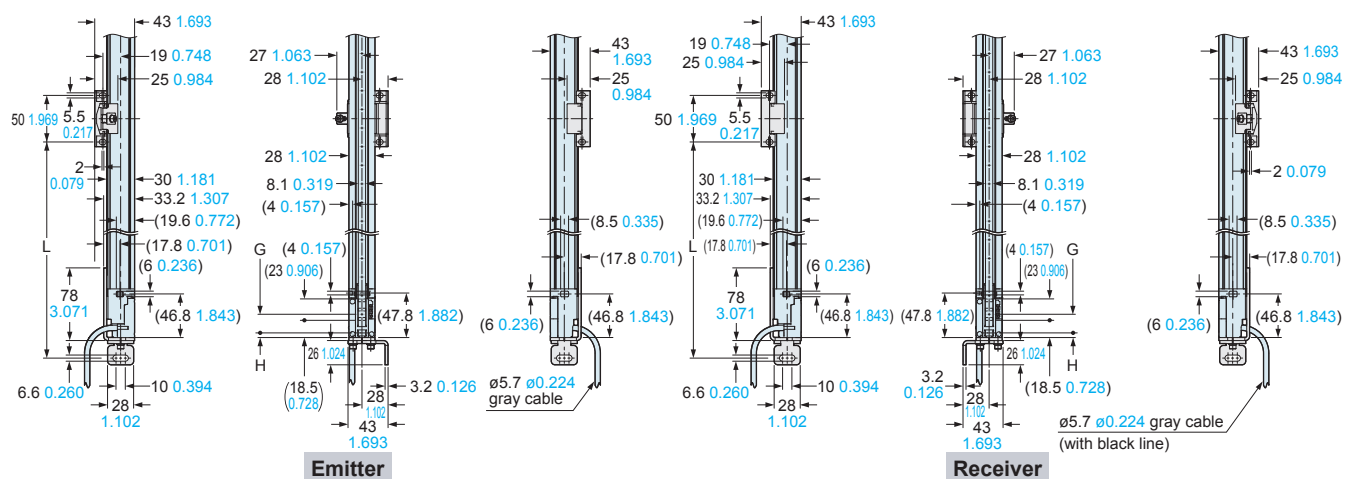

Model No.	Protective height		Mounting pitch	Total length	Intermediate support bracket mounting pitch (Note 2)	Model No.	Beam pitch	First beam channel position
	A (Note 1)							
	SF4D-F□(-01)	SF4D-A□(-01)						
SF4D-F15(-01)	SF4D-H8(-01)	SF4D-A4(-01)	140 5.512	120 4.724	150 5.906	194 7.638	208 8.189	—
SF4D-F23(-01)	SF4D-H12(-01)	SF4D-A6(-01)	220 8.661	200 7.874	230 9.055	274 10.787	288 11.339	—
SF4D-F31(-01)	SF4D-H16(-01)	SF4D-A8(-01)	300 11.811	280 11.024	310 12.205	354 13.937	368 14.488	—
SF4D-F39(-01)	SF4D-H20(-01)	SF4D-A10(-01)	380 14.961	360 14.173	390 15.354	434 17.087	448 17.638	—
SF4D-F47(-01)	SF4D-H24(-01)	SF4D-A12(-01)	460 18.110	440 17.323	470 18.504	514 20.236	528 20.787	—
SF4D-F55(-01)	SF4D-H28(-01)	SF4D-A14(-01)	540 21.260	520 20.472	550 21.654	594 23.386	608 23.937	—
SF4D-F63(-01)	SF4D-H32(-01)	SF4D-A16(-01)	620 24.409	600 23.622	630 24.803	674 26.535	688 27.087	—
SF4D-F71(-01)	SF4D-H36(-01)	SF4D-A18(-01)	700 27.559	680 26.772	710 27.953	754 29.685	768 30.236	—
SF4D-F79(-01)	SF4D-H40(-01)	SF4D-A20(-01)	780 30.709	760 29.921	790 31.102	834 32.835	848 33.386	—
SF4D-F95(-01)	SF4D-H48(-01)	SF4D-A24(-01)	940 37.008	920 36.220	950 37.402	994 39.134	1,008 39.685	—
SF4D-F111(-01)	SF4D-H56(-01)	SF4D-A28(-01)	1,100 43.307	1,080 42.520	1,110 43.701	1,154 45.433	1,168 45.984	552 21.732
SF4D-F127(-01)	SF4D-H64(-01)	SF4D-A32(-01)	1,260 49.606	1,240 48.819	1,270 50.000	1,314 51.732	1,328 52.283	632 24.882
—	SF4D-H72(-01)	SF4D-A36(-01)	1,420 55.906	1,400 55.118	1,430 56.299	1,474 58.031	1,488 58.583	712 28.031
—	SF4D-H80(-01)	SF4D-A40(-01)	1,580 62.205	1,560 61.417	1,590 62.598	1,634 64.331	1,648 64.882	792 31.181
—	SF4D-H88(-01)	SF4D-A44(-01)	1,740 68.504	1,720 67.717	1,750 68.898	1,794 70.630	1,808 71.181	872 34.331
—	SF4D-H96(-01)	SF4D-A48(-01)	1,900 74.803	1,880 74.016	1,910 75.197	1,954 76.929	1,968 77.480	952 37.480

Notes: 1) In the case of "When used as safety device for presses in China" or "When SF4D-□(-01) is used for presses or shearing machines (paper cutting machines) in Japan," the distance between the center of the first beam axis and the center of the last beam axis of the device becomes the protective height (A).  
 2) When the number of beam channels is SF4D-F□(-01): 111 or more beam channels, SF4D-H□(-01): 56 or more beam channels, SF4D-A□(-01): 28 or more beam channels, one set is required.



**SF4D-□(-01)**

**Safety light curtain**

**Assembly dimensions**

Mounting drawing for the safety light curtains using the beam adjustment mounting bracket **MS-SFD-1-8** (optional) and the intermediate support brackets **MS-SFB-2** (optional).

**<Rear mounting>**

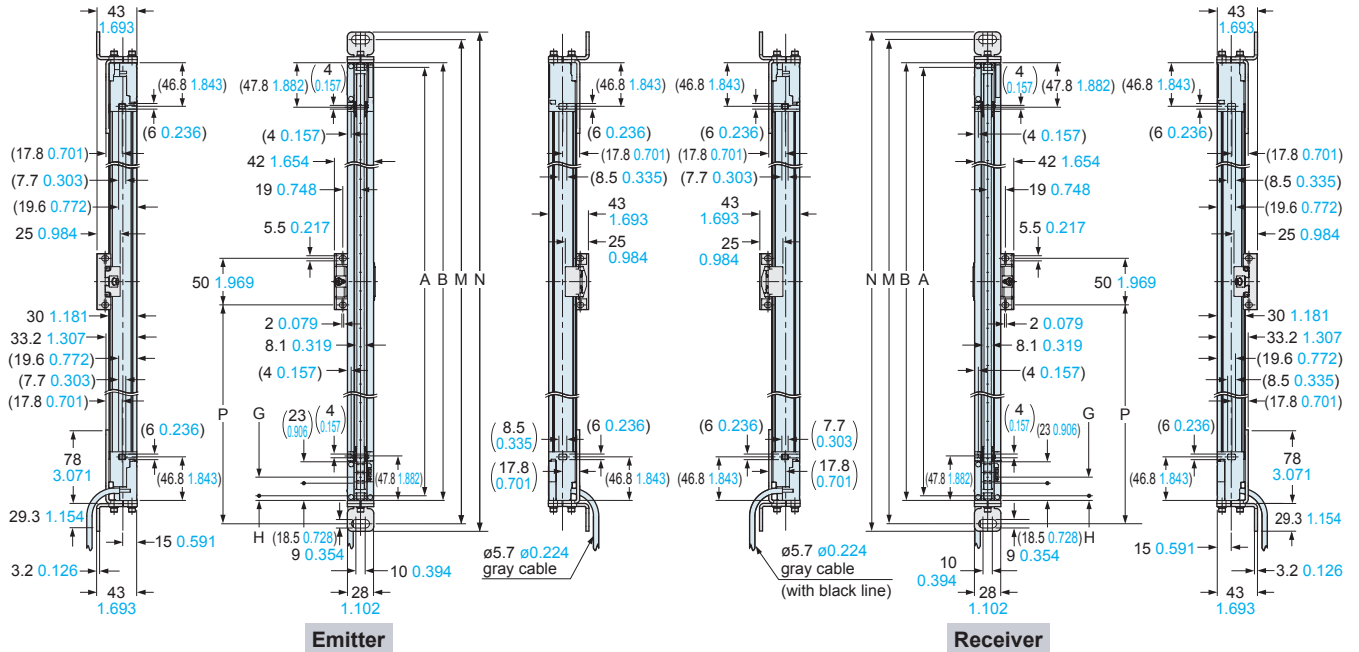

**<Side mounting>**

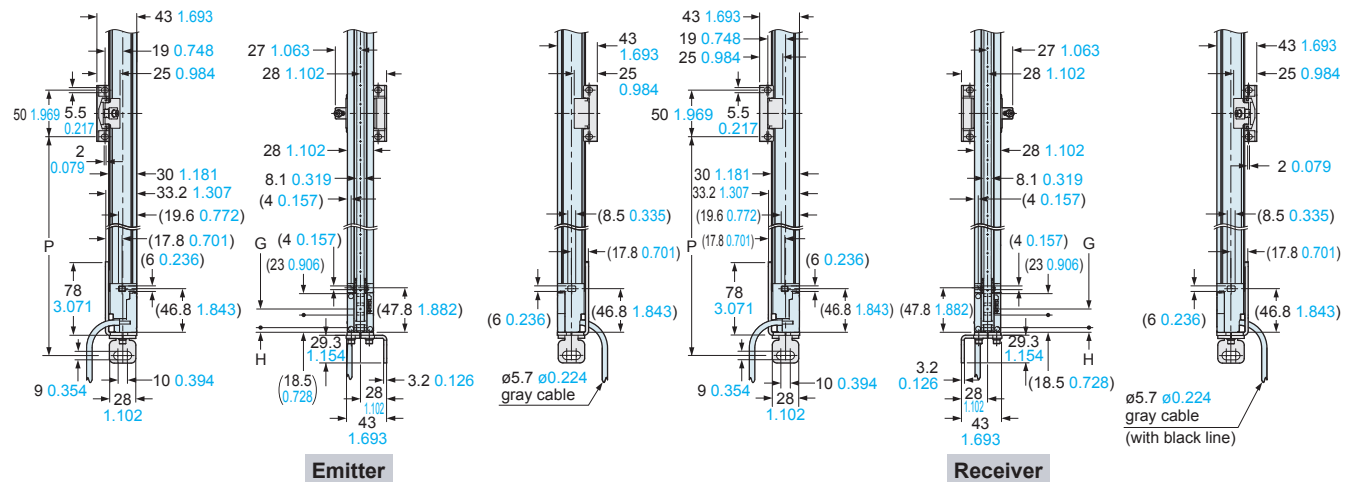

Model No.	Protective height		Mounting pitch	Total length	Intermediate support bracket mounting pitch (Note 2)	Model No.	Beam pitch	First beam channel position			
	A (Note 1)								B	M	N
	SF4D-F□(-01)	SF4D-A□(-01)									
SF4D-F15(-01)	SF4D-H8(-01)	SF4D-A4(-01)	140 5.512	120 4.724	150 5.906	199 7.835	215 8.465	—			
SF4D-F23(-01)	SF4D-H12(-01)	SF4D-A6(-01)	220 8.661	200 7.874	230 9.055	279 10.984	295 11.614	—			
SF4D-F31(-01)	SF4D-H16(-01)	SF4D-A8(-01)	300 11.811	280 11.024	310 12.205	359 14.134	375 14.764	—			
SF4D-F39(-01)	SF4D-H20(-01)	SF4D-A10(-01)	380 14.961	360 14.173	390 15.354	439 17.283	455 17.913	—			
SF4D-F47(-01)	SF4D-H24(-01)	SF4D-A12(-01)	460 18.110	440 17.323	470 18.504	519 20.433	535 21.063	—			
SF4D-F55(-01)	SF4D-H28(-01)	SF4D-A14(-01)	540 21.260	520 20.472	550 21.654	599 23.583	615 24.213	—			
SF4D-F63(-01)	SF4D-H32(-01)	SF4D-A16(-01)	620 24.409	600 23.622	630 24.803	679 26.732	695 27.362	—			
SF4D-F71(-01)	SF4D-H36(-01)	SF4D-A18(-01)	700 27.559	680 26.772	710 27.953	759 29.882	775 30.512	—			
SF4D-F79(-01)	SF4D-H40(-01)	SF4D-A20(-01)	780 30.709	760 29.921	790 31.102	839 33.031	855 33.661	—			
SF4D-F95(-01)	SF4D-H48(-01)	SF4D-A24(-01)	940 37.008	920 36.220	950 37.402	999 39.331	1,015 39.961	—			
SF4D-F111(-01)	SF4D-H56(-01)	SF4D-A28(-01)	1,100 43.307	1,080 42.520	1,110 43.701	1,159 45.630	1,175 46.260	555 21.850			
SF4D-F127(-01)	SF4D-H64(-01)	SF4D-A32(-01)	1,260 49.606	1,240 48.819	1,270 50.000	1,319 51.929	1,335 52.559	635 25.000			
—	SF4D-H72(-01)	SF4D-A36(-01)	1,420 55.906	1,400 55.118	1,430 56.299	1,479 58.228	1,495 58.858	715 28.150			
—	SF4D-H80(-01)	SF4D-A40(-01)	1,580 62.205	1,560 61.417	1,590 62.598	1,639 64.528	1,655 65.157	795 31.299			
—	SF4D-H88(-01)	SF4D-A44(-01)	1,740 68.504	1,720 67.717	1,750 68.898	1,799 70.827	1,815 71.457	875 34.449			
—	SF4D-H96(-01)	SF4D-A48(-01)	1,900 74.803	1,880 74.016	1,910 75.197	1,959 77.126	1,975 77.756	955 37.598			

Notes: 1) In the case of "When used as safety device for presses in China" or "When SF4D-□(-01) is used for presses or shearing machines (paper cutting machines) in Japan," the distance between the center of the first beam axis and the center of the last beam axis of the device becomes the protective height (A).  
 2) When the number of beam channels is SF4D-F□(-01): 111 or more beam channels, SF4D-H□(-01): 56 or more beam channels, SF4D-A□(-01): 28 or more beam channels, one set is required.

**SF4D-□(-01)**

Safety light curtain

**Assembly dimensions**

Mounting drawing for the safety light curtains using the dead zoneless beam adjustment mounting bracket **MS-SFD-3-6** (optional)

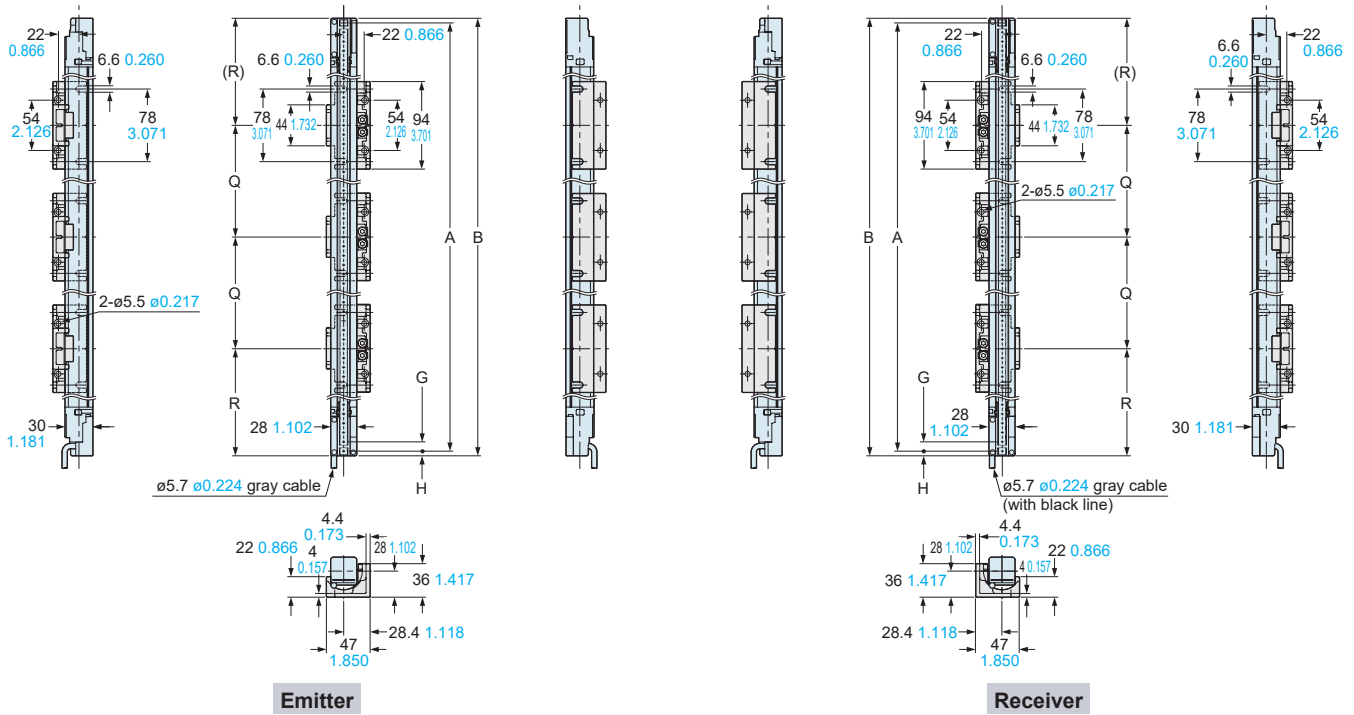

Model No.			Protective height			Dead zoneless mounting bracket		
			A (Note)		B	Mounting position		Required number of brackets for emitters / receivers
			SF4D-F□(-01)	SF4D-A□(-01)		Q	R	
SF4D-F15(-01)	SF4D-H8(-01)	SF4D-A4(-01)	140 5.512	120 4.724	150 5.906	0 0	75 2.953	2
SF4D-F23(-01)	SF4D-H12(-01)	SF4D-A6(-01)	220 8.661	200 7.874	230 9.055	94 3.701	68 2.677	
SF4D-F31(-01)	SF4D-H16(-01)	SF4D-A8(-01)	300 11.811	280 11.024	310 12.205	110 4.331	100 3.937	
SF4D-F39(-01)	SF4D-H20(-01)	SF4D-A10(-01)	380 14.961	360 14.173	390 15.354	160 6.299	115 4.528	
SF4D-F47(-01)	SF4D-H24(-01)	SF4D-A12(-01)	460 18.110	440 17.323	470 18.504	200 7.874	135 5.315	
SF4D-F55(-01)	SF4D-H28(-01)	SF4D-A14(-01)	540 21.260	520 20.472	550 21.654	250 9.843	150 5.906	
SF4D-F63(-01)	SF4D-H32(-01)	SF4D-A16(-01)	620 24.409	600 23.622	630 24.803	290 11.417	170 6.693	
SF4D-F71(-01)	SF4D-H36(-01)	SF4D-A18(-01)	700 27.559	680 26.772	710 27.953	340 13.386	185 7.283	
SF4D-F79(-01)	SF4D-H40(-01)	SF4D-A20(-01)	780 30.709	760 29.921	790 31.102	380 14.961	205 8.071	
SF4D-F95(-01)	SF4D-H48(-01)	SF4D-A24(-01)	940 37.008	920 36.220	950 37.402	470 18.504	240 9.449	
SF4D-F111(-01)	SF4D-H56(-01)	SF4D-A28(-01)	1,100 43.307	1,080 42.520	1,110 43.701	560 22.047	275 10.827	4
SF4D-F127(-01)	SF4D-H64(-01)	SF4D-A32(-01)	1,260 49.606	1,240 48.819	1,270 50.000	650 25.591	310 12.205	
	SF4D-H72(-01)	SF4D-A36(-01)	1,420 55.906	1,400 55.118	1,430 56.299	730 28.740	350 13.780	
	SF4D-H80(-01)	SF4D-A40(-01)	1,580 62.205	1,560 61.417	1,590 62.598	530 20.866	265 10.433	
	SF4D-H88(-01)	SF4D-A44(-01)	1,740 68.504	1,720 67.717	1,750 68.898	590 23.228	285 11.220	6
	SF4D-H96(-01)	SF4D-A48(-01)	1,900 74.803	1,880 74.016	1,910 75.197	650 25.591	305 12.008	

Model No.	Beam pitch	First beam channel position
	G	H
SF4D-F□(-01)	10 0.394	5 0.197
SF4D-H□(-01)	20 0.787	5 0.197
SF4D-A□(-01)	40 1.575	15 0.591

Note: In the case of "When used as safety device for presses in China" or "When SF4D-□(-01) is used for presses or shearing machines (paper cutting machines) in Japan," the distance between the center of the first beam axis and the center of the last beam axis of the device becomes the protective height (A).

**SF4D-□(-01)**

**Safety light curtain**

**Assembly dimensions**

Mounting drawing for safety light curtains using the **SF4B-G** compatible mounting bracket **MS-SFD-4BG** (optional) and the intermediate support bracket **MS-SFB-2**.

**<Rear mounting>**

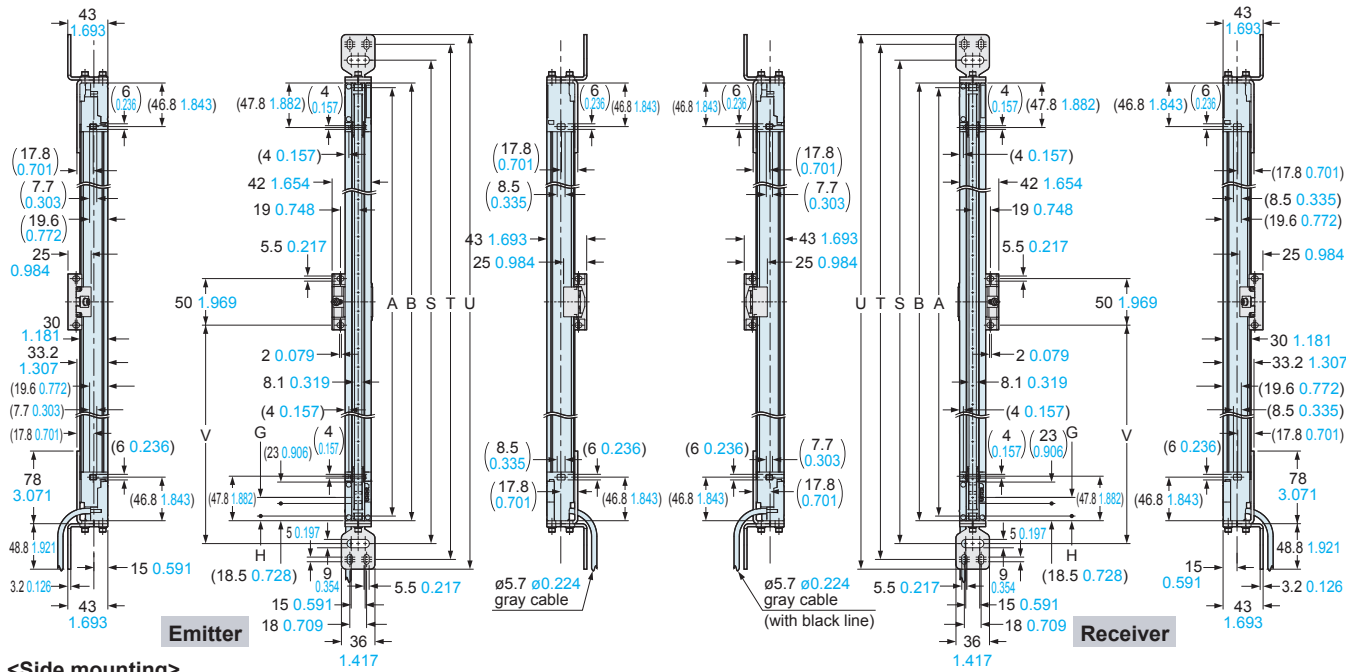

**<Side mounting>**

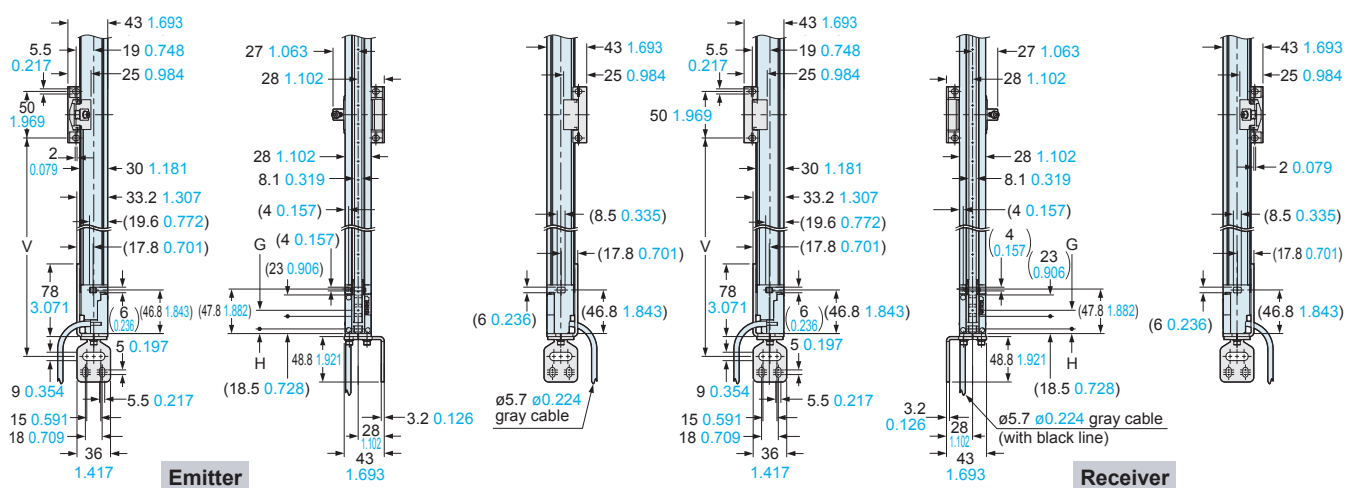

Model No.	Protective height			Mounting pitch		Total length	Intermediate support bracket mounting pitch (Note 4)	Model No.	Beam pitch	First beam channel position		
	A (Note 1)		B	S (Note 2)	T (Note 3)						U	V
	SF4D-F□(-01)	SF4D-A□(-01)										
SF4D-F15(-01)	SF4D-H8(-01)	SF4D-A4(-01)	140 5.512	120 4.724	150 5.906	199 7.835	233 9.173	254 10.000	—	—		
SF4D-F23(-01)	SF4D-H12(-01)	SF4D-A6(-01)	220 8.661	200 7.874	230 9.055	279 10.984	313 12.323	334 13.150	—	—		
SF4D-F31(-01)	SF4D-H16(-01)	SF4D-A8(-01)	300 11.811	280 11.024	310 12.205	359 14.134	393 15.472	414 16.299	—	—		
SF4D-F39(-01)	SF4D-H20(-01)	SF4D-A10(-01)	380 14.961	360 14.173	390 15.354	439 17.283	473 18.622	494 19.449	—	—		
SF4D-F47(-01)	SF4D-H24(-01)	SF4D-A12(-01)	460 18.110	440 17.323	470 18.504	519 20.433	553 21.772	574 22.598	—	—		
SF4D-F55(-01)	SF4D-H28(-01)	SF4D-A14(-01)	540 21.260	520 20.472	550 21.654	599 23.583	633 24.921	654 25.748	—	—		
SF4D-F63(-01)	SF4D-H32(-01)	SF4D-A16(-01)	620 24.409	600 23.622	630 24.803	679 26.732	713 28.071	734 28.898	—	—		
SF4D-F71(-01)	SF4D-H36(-01)	SF4D-A18(-01)	700 27.559	680 26.772	710 27.953	759 29.882	793 31.220	814 32.047	—	—		
SF4D-F79(-01)	SF4D-H40(-01)	SF4D-A20(-01)	780 30.709	760 29.921	790 31.102	839 33.031	873 34.370	894 35.197	—	—		
SF4D-F95(-01)	SF4D-H48(-01)	SF4D-A24(-01)	940 37.008	920 36.220	950 37.402	999 39.331	1,033 40.669	1,054 41.496	—	—		
SF4D-F111(-01)	SF4D-H56(-01)	SF4D-A28(-01)	1,100 43.307	1,080 42.520	1,110 43.701	1,159 45.630	1,193 46.969	1,214 47.795	555 21.850	—		
SF4D-F127(-01)	SF4D-H64(-01)	SF4D-A32(-01)	1,260 49.606	1,240 48.819	1,270 50.000	1,319 51.929	1,353 53.268	1,374 54.094	635 25.000	—		
—	SF4D-H72(-01)	SF4D-A36(-01)	1,420 55.906	1,400 55.118	1,430 56.299	1,479 58.228	1,513 59.567	1,534 60.394	715 28.150	—		
—	SF4D-H80(-01)	SF4D-A40(-01)	1,580 62.205	1,560 61.417	1,590 62.598	1,639 64.528	1,673 65.866	1,694 66.693	795 31.299	—		
—	SF4D-H88(-01)	SF4D-A44(-01)	1,740 68.504	1,720 67.717	1,750 68.898	1,799 70.827	1,833 72.165	1,854 72.992	875 34.449	—		
—	SF4D-H96(-01)	SF4D-A48(-01)	1,900 74.803	1,880 74.016	1,910 75.197	1,959 77.126	1,993 78.465	2,014 79.291	955 37.598	—		

Notes: 1) In the case of "When used as safety device for presses in China" or "When SF4D-□(-01) is used for presses or shearing machines (paper cutting machines) in Japan," the distance between the center of the first beam axis and the center of the last beam axis of the device becomes the protective height (A).  
 2) Mounting pitch when the SF4B-G compatible mounting bracket MS-SFD-4BG (optional) is installed using one M8 hexagon socket head bolt.  
 3) Mounting pitch when the SF4B-G compatible mounting bracket MS-SFD-4BG (optional) is installed using two M5 hexagon socket head bolts.  
 4) When the number of beam channels is SF4D-F□(-01): 111 or more beam channels, SF4D-H□(-01): 56 or more beam channels, SF4D-A□(-01): 28 or more beam channels, one set is required.

**MS-SFD-1-5** Beam adjustment mounting bracket (Optional)

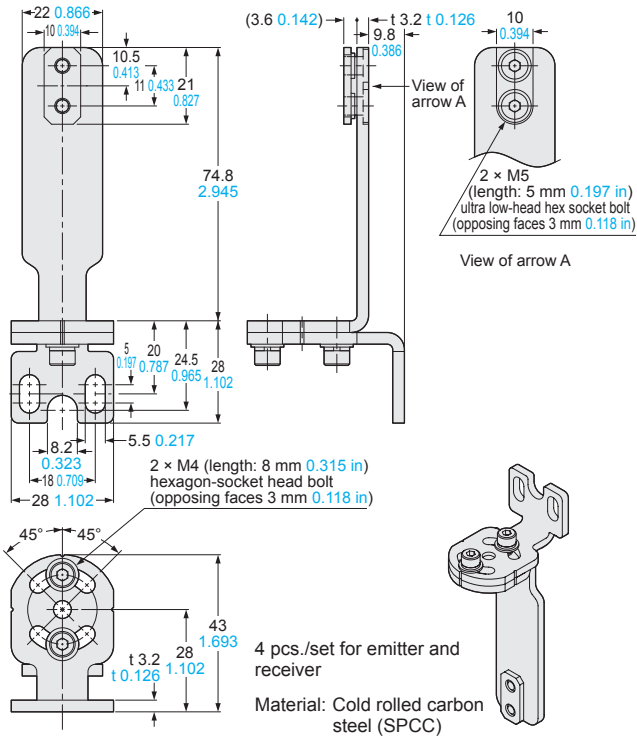

**MS-SFD-1-6** Beam adjustment mounting bracket (Optional)

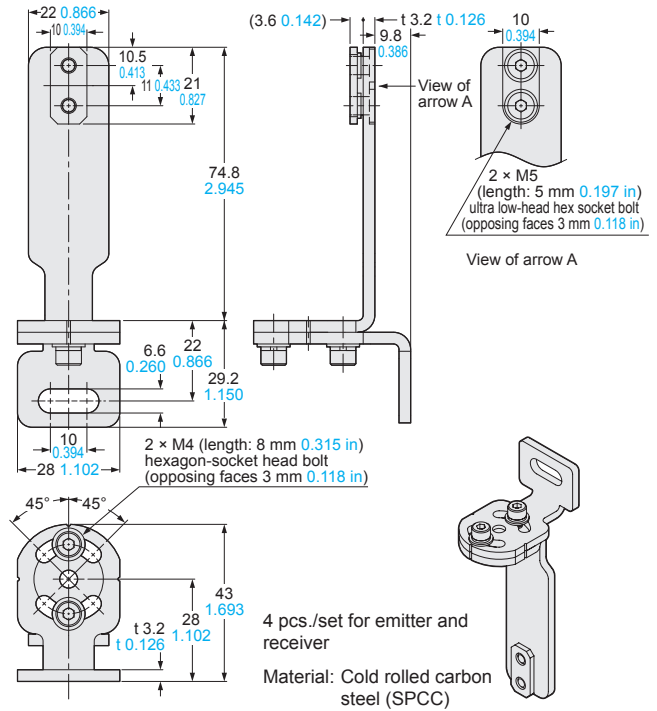

**MS-SFD-1-8** Beam adjustment mounting bracket (Optional)

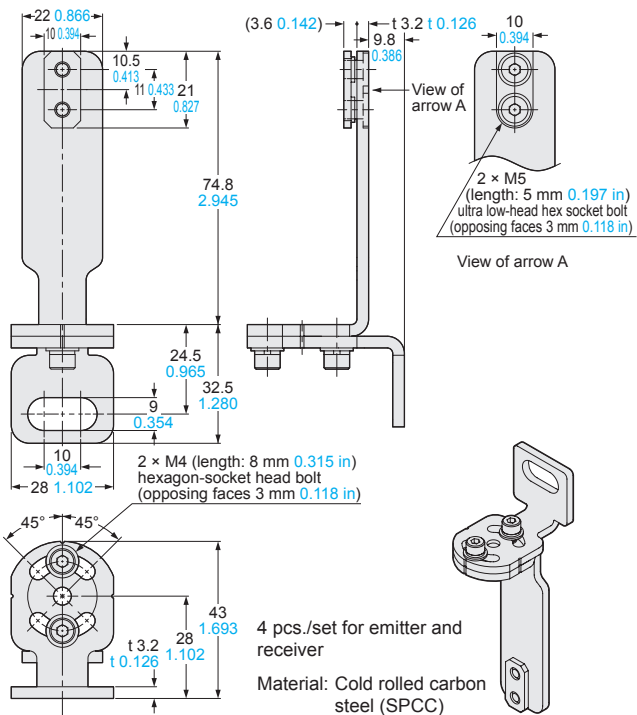

**MS-SFD-3-6** Dead zoneless beam adjustment mounting bracket (Optional)

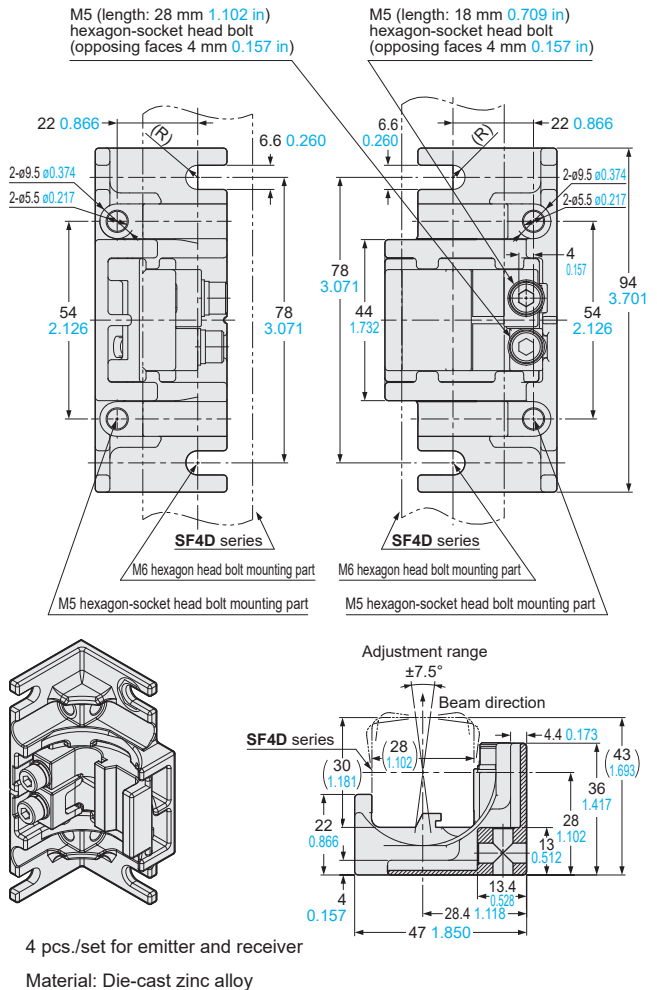

**MS-SFB-2**

Intermediate support bracket (Optional)

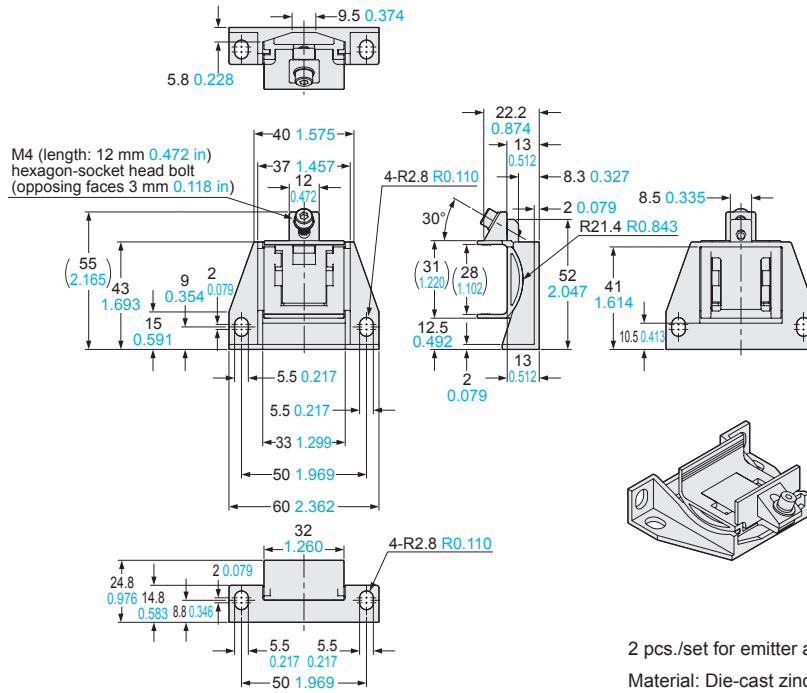

**MS-SFD-4BG SF4B-G compatible mounting bracket (Optional)**

**SF4D-TM1** Communication module (Optional)

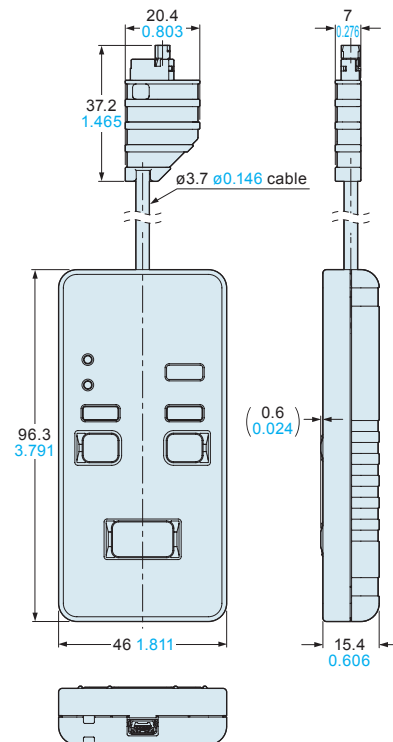
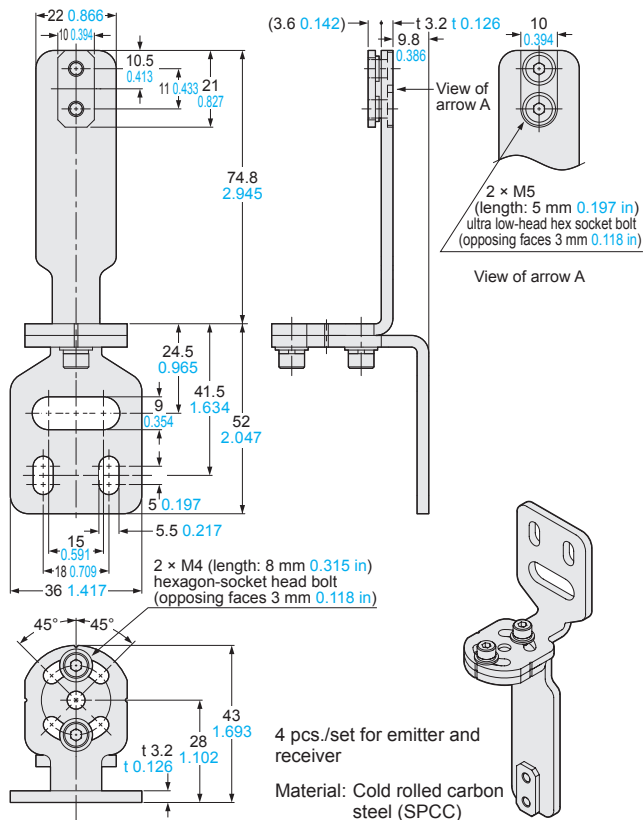

**SFD-WL3**

IO-Link communication unit (Optional)

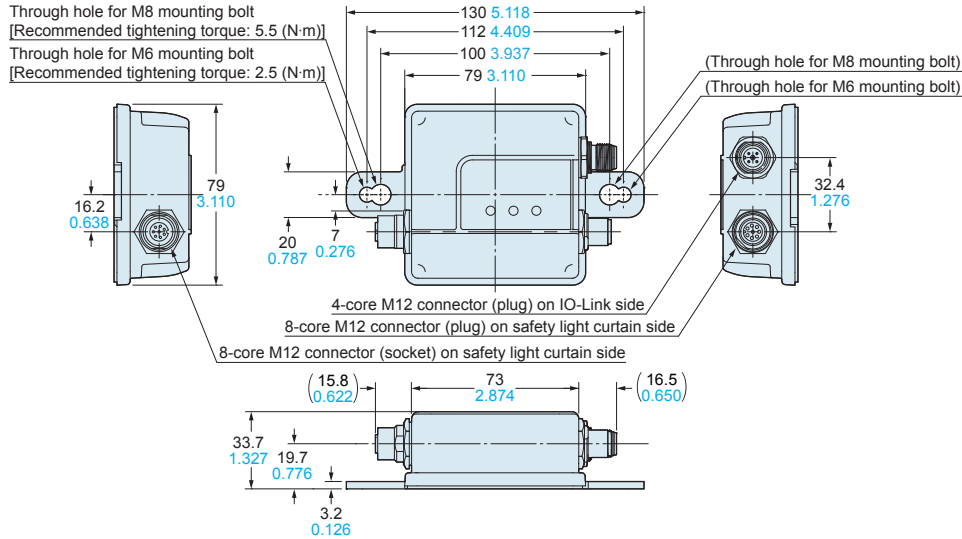

**SF-C21**

Control units (Optional)

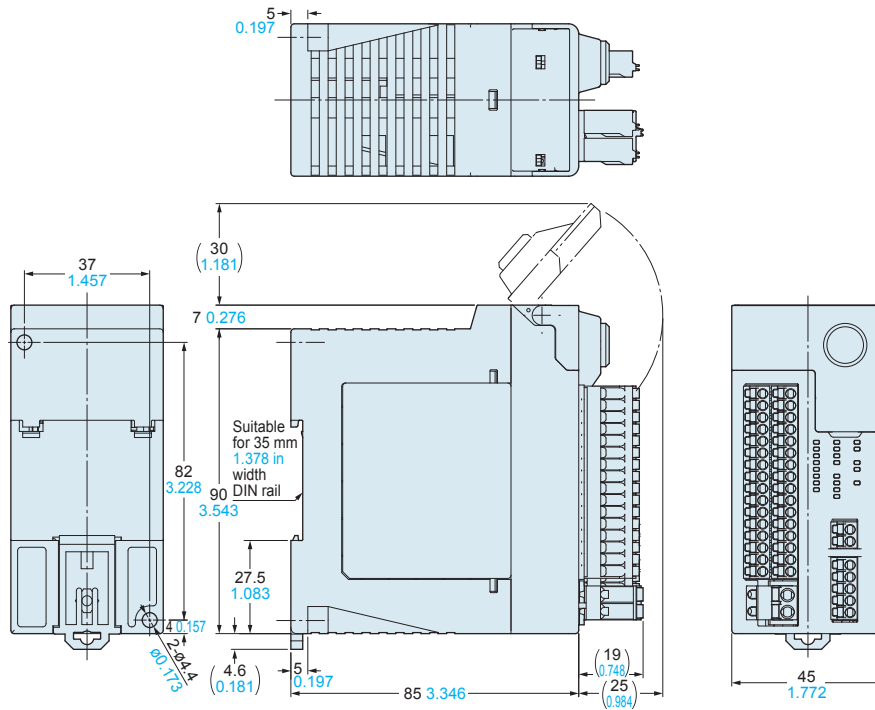

**SF-C11**

Control units (Optional)

**SF-C13**

Control units (Optional)

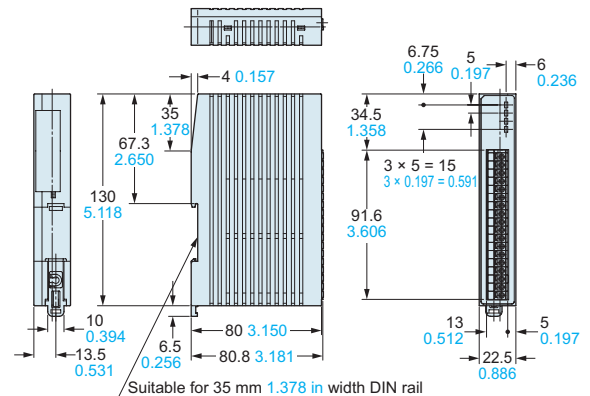
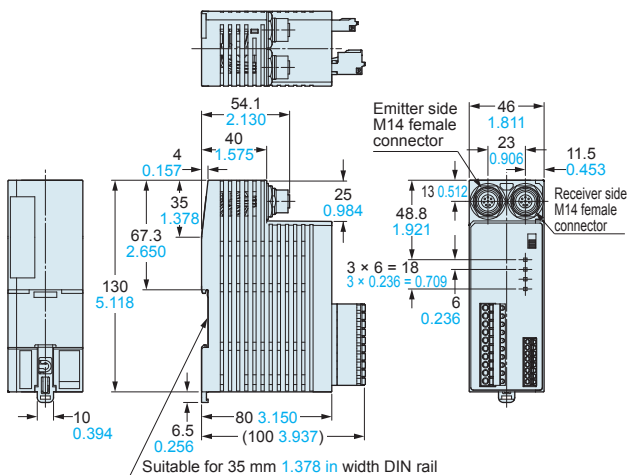



## Introduction to Panasonic sensors that can be used as muting sensors

### Compact Photoelectric Sensor CX-400 SERIES Ver.2

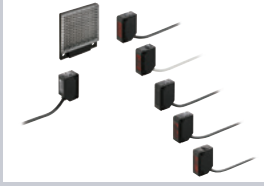

- World standard size
- Wide variation

### Ultra-slim Photoelectric Sensor EX-10 SERIES Ver.2



- 3.5 mm **0.138 in** thickness
- Long sensing range: 1 m **3.281 ft** (thru-beam type: **EX-19**)
- \* The **EX-20** series that is compatible with M3 mounting screws is also available.

### U-shaped Micro Photoelectric Sensor PM-25/45/65 SERIES

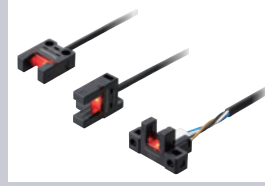

- Three protection circuits standard on all models
- Ample beam emitting / receiving distance of 6 mm **0.236 in**
- Easy to mount with M3 screws

### Rectangular-shaped Inductive Proximity Sensor GX-F/H SERIES



- Industry longest in stable sensing range
- 10 times the durability (Compared to previous models)
- IP68G rating

## Non-Contact Safety Door Switch

Large and Bright Indicators Show the **Open/Close** Conditions of All Equipment Doors.

Non-Contact Safety Door Switch

### SG-P SERIES

Compatible with Up to Control Category 4, PL<sub>e</sub> and SIL3  
\* Control category varies depending on external circuit configurations and wirings.

For frame-less doors  
Compact type  
SG-P1010-□ / SG-P2010-□



For framed doors  
Visible type  
SG-P1020-□ / SG-P2020-□



#### Flashing Function

If any one of the safety switches connected in series is not detected, the indicator lights of the other safety switches will blink green to notify the operator.

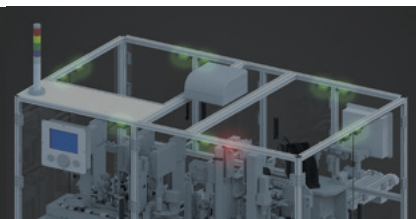

#### Serial Connection of Up to 30 Units

There is no need to purchase a dedicated controller. The presently used safety controller / circuit can be connected directly. Up to 30 units can be connected, thus contributing to wire-saving.

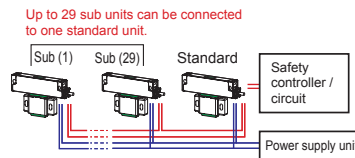

#### Helps Prevent Intentional Deactivation of Safety Function

The SG-P series products are available with two different coding levels: High-code models and Low-code models. The High-code models are compatible with ISO 14119: 2013 coding level (**high level coded actuators**) and prevent intentional deactivation of their safety function.

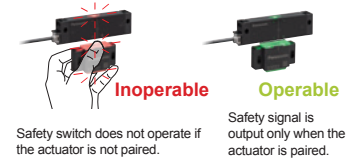

## Disclaimer

The applications described in the catalog are all intended for examples only. The purchase of our products described in the catalog shall not be regarded as granting of a license to use our products in the described applications. We do NOT warrant that we have obtained some intellectual properties, such as patent rights, with respect to such applications, or that the described applications may not infringe any intellectual property rights, such as patent rights, of a third party.

**Panasonic**  
INDUSTRY

**Panasonic Industry Co., Ltd.**

Industrial Device Business Division  
7-1-1, Morofuku, Daito-shi, Osaka 574-0044, Japan  
industry.panasonic.com