

Type 4 Compatible with Up to Control Category 4, PLe and SIL3

Flameproof Type Safety Light Curtain BSF4-AH80



BSF4-AH80



Compliant up to Control Category 4, PL_e, SIL3

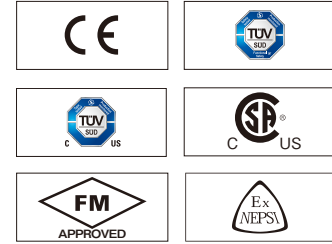

* Please contact us about the type approval No. in China.

The control category differs depending on the configuration and wiring of the external circuit.

Globally-compliant flameproof structure

Complies with worldwide flameproof standards

The safety light curtain is built into a highly flameproof enclosure conforming to the IEC 61496 (Type 4). The safety light curtain can be safely used in any workplace throughout the world where flameproof performance is required.

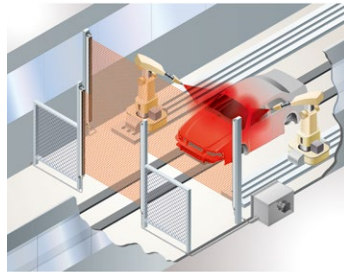

Ample protective height 1,595 mm 62.795 in

A single safety light curtain is sufficient for production lines with high working heights such as vehicle body .



Europe

Complies with flameproof structures (Ex db [op is] II B T6 Gb) specified by EN IEC 60079-0, EN 60079-1, EN 60079-28 and ATEX Directives (2014/34/EU).

United States

Complies with flameproof structures (Class I, Zone 1, AEx d II B T6) specified by FM Class 3600, (ANSI/ISA-12.22.01)

Canada

Complies with flameproof structures (Ex d II B T6) specified by CAN/CSA-E60079-0.

China

Complies with flameproof structures (Ex d II B T6 Gb) specified by GB 3836.1-2010 (GB 3836.2-2010)

Japan

Complies with flameproof structures (Ex d II B T6) according to technical standards conforming to international standards.

Hazardous locations: Zone 1 location, Zone 2 location
Classification of gas or vapor, and Temperature classification: II B T6

Mounting bracket enables easy beam-axis alignment

The beam-axis alignment is easy since angle adjustment is possible with the enclosed rear mounting bracket.

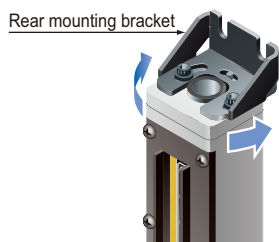

Less operating errors from extraneous light interference

A double-scanning method and retry processing are some unique new technology that help to avoid momentary interference from extraneous light coming from nearby equipment. A reduction in operating errors resulting from extraneous light interference can mean less frequent machinery stoppages and reduces the amount of time that a production line is not running.

Mutual interference is reduced without the need for interference prevention lines

No interference prevention lines are required between different items of equipment, so that safety light curtains can be installed with greater flexibility.

ORDER GUIDE

Safety light curtain

Type	Operating range (Note)	Model No. (Part No.)	Number of beam channels	Protective height (mm in)
20 mm 0.787 in beam pitch	0.3 to 6 m 0.984 to 19.685 ft	BSF4-AH80 (UBSF4AH80V2)	80	1,595 62.795

Note: The operating range is the possible setting distance between the emitter and the receiver.

Control unit

Designation	Appearance	Model No. (Part No.)	Description
Slim type control unit		SF-C13 (USFC13)	For PNP/NPN equivalent output type safety light curtain. Compatible with Control Category 4. Use in a safe location.

SPECIFICATIONSRefer to web site for details of the specifications for **SF-C13**.

Model No.	BSF4-AH80	
Item		
Applicable flameproof standards	Europe: EN IEC 60079-0, EN60079-1, EN 60079-28 USA: FM 3600 (ANSI/ISA 12.22.01) Canada: CAN/CSA-E60079 China: GB 3836.1-2010 (GB 3836.2-2010) Japan: Technical standard conforming to international standards	
CE marking directive compliance	ATEX Directive, Machinery Directive, EMC Directive, RoHS Directive	
Flameproof capability	Europe: Ex db [op is] IIB T6 Gb USA: Class I, Zone 1 AEx d IIB T6 Canada / Japan: Ex d IIB T6 China: Ex d IIB T6 Gb	
Setup location	Hazardous locations such as Zone 1 or Zone 2 where "IIB T6" gases or vapors may be present (Note 2)	
Applicable standards	ISO 13849-1:2015 (Category 4, PL _e), EN ISO 13849-1:2015 (Category 4, PL _e), IEC 61508-1 to 4 (SIL 3), EN 50178, EN 55011, EN 61000-6-2, EN 61496-1 (Type 4), IEC 61496-1/2 (Type 4), UL 61496-1/2 (Type 4), CAN/CSA-C22.2 No. 14	
Protective height	1,595 mm 62.795 in	
Beam pitch / Operating range	20 mm 0.787 in / 0.3 to 6 m 0.984 to 19.686 ft	
Min. sensing object	ø30 mm ø1.181 in opaque object	
Effective aperture angle	±2.5° or less [for an operating range exceeding 3 m 9.843 ft (conforming to IEC 61496-2 / UL 61496-2)]	
Supply voltage	24 V DC ±10 % Ripple P-P 10 % or less	
Current consumption	Emitter: 130 mA or less, Receiver: 125 mA or less	
Control outputs (OSSD1, OSSD2)	Semiconductor output (PNP output equivalent) 2 outputs <ul style="list-style-type: none"> • Maximum source current: 200 mA • Applied voltage: Same as supply voltage (between control output and +V) • Residual voltage: 3.0 V or less (at 200 mA source current) 	
Operation mode / Protection circuit	ON when all beam channels are received, OFF when one or more beam channels are interrupted (OFF also in case of any malfunction in the safety light curtain or the synchronization signal) / Incorporated	
Response time	OFF response 11 ms or less, ON response 70 ms or less	
Auxiliary output (Non-safety output)	PNP open-collector transistor <ul style="list-style-type: none"> • Maximum source current: 60 mA • Applied voltage: Same as supply voltage (between auxiliary output and +V) • Residual voltage: 2.5 V or less (at 60 mA source current) 	
Operation mode / Protection circuit	OFF when control outputs are ON, ON when control outputs are OFF / Incorporated	
Indicators	Emitter <p>Top beam-axis alignment indicator: 2-color (Red / Blue) LED (lights up in blue when control outputs are ON, lights up in red when the topmost beam channel receives light, lights off when the topmost beam channel is interrupted) Bottom beam-axis alignment indicator: 2-color (Red / Blue) LED (lights up in blue when control outputs are ON, lights up in red when the bottommost beam channel receives light, lights off when the bottom most beam channel is interrupted) Emission control indicator: Orange LED (lights up in orange during emission halt, lights off during normal operation) Operation indicator: 2-color (Red / Green) LED (lights up in red when control outputs are OFF, lights up in green when control outputs are ON) Fault indicator: Yellow LED (lights up or blinks if a fault occurs in the safety light curtain)</p>	
	Receiver <p>Top beam-axis alignment indicator: 2-color (Red / Blue) LED (lights up in blue when control outputs are ON, lights up in red when the topmost beam channel receives light, lights off when the topmost beam channel is interrupted) Bottom beam-axis alignment indicator: 2-color (Red / Blue) LED (lights up in blue when control outputs are ON, lights up in red when the bottommost beam channel receives light, lights off when the bottom most beam channel is interrupted) Stable light indicator : 2-color (Green / Orange) LED (lights up in green when stable light state, lights up in orange when unstable light state, lights off when beam channels are interrupted) OSSD indicator: 2-color (Red / Green) LED (lights up in red when control outputs are OFF, lights up in green when control outputs are ON) Fault indicator: Yellow LED (lights up or blinks if a fault occurs in the safety light curtain)</p>	
Test input (emission halt) function	Incorporated	
Test input (emission halt input)	Emission: Vs-2.5 V to Vs (sink current: 5 mA or less) (Note 3), Emission halt: Open, or 0 to +1.5 V	
Environmental resistance	Degree of protection	IP65 (IEC)
	Ambient temperature / Ambient humidity	-10 to +40 °C +14 to +104 °F (No dew condensation or icing allowed), Storage: -20 to +55 °C -4 to +131 °F / 45 to 85 % RH, Storage: 45 to 85 % RH
	Ambient illuminance	Incandescent light: 5,000 lx or less at the light-receiving face
	Dielectric strength voltage	1,000 V AC for one min. between all supply terminals connected together and safety light curtain grounding terminal (Note 4)
	Insulation resistance	20 MΩ, or more, with 500 V DC megger between all supply terminals connected together and safety light curtain grounding terminal (Note 4)
	Vibration resistance	10 to 55 Hz frequency, 0.35 mm 0.014 in double amplitude in X, Y and Z directions for 20 times each
	Shock resistance	100 m/s ² acceleration (10 G approx.) with pulse width 16 ms in X, Y and Z directions 1,000 times each
Altitude (Atmospheric pressure)	2,000 m 6561 ft or less (800 to 1,100 hPa)	
Emitting element	Infrared LED (Peak emission wavelength: 850 nm 0.033 mil)	
Material	Flameproof enclosure: Aluminum, Lid: Aluminum die-cast, Clear window: Glass, Window frame: Steel plate (Black chromate) Window packing: Chloroprene, Safety light curtain mounting bracket: Steel plate (Black chromate), Cable: Oil-resistant PVC, Cable Gland: Brass (Nickel plated)	
Cable	6-core (0.3 mm ² × 4-core, 0.2 mm ² × 2-core) shielded cable, 20 m 65.617 ft long	
Weight (Total of emitter and receiver)	Net weight: 44 kg approx.	
Accessories	Rear sensor mounting bracket: 1 set for emitter and receiver, Test rod: 1 pc. Gland adapter (Internal thread G 1/2): 2 pcs.	

Notes: 1) Where measurement conditions have not been specified precisely, the conditions used were an ambient temperature of +20 °C **+68 °F**.

2) Install the product in a location where it is less likely to suffer mechanical damage.

3) Vs is the same value as the voltage of the used power supply to be used.

4) It shows the specifications of the built-in safety light curtain.

I/O CIRCUIT AND WIRING DIAGRAMS

I/O circuit diagram

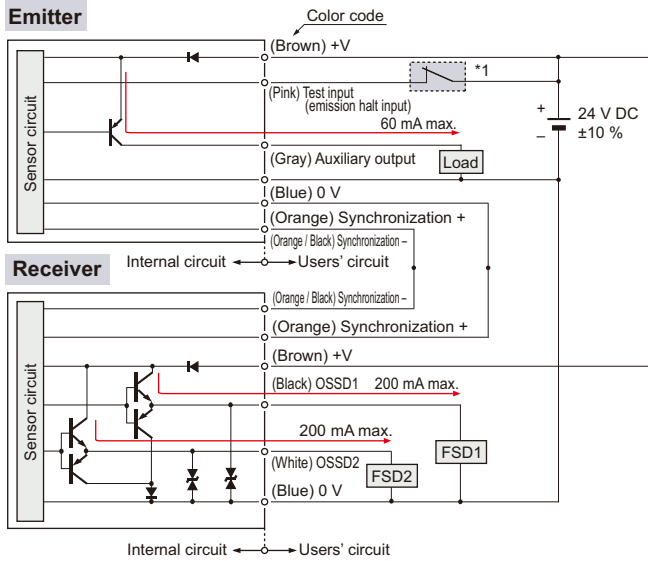

- Use a safety relay unit or an equivalent safety control circuit for FSD.
- Ground the cable of shield without fail.

* 1

Non-voltage contact or PNP open-collector transistor

- Test input (emission halt input)
Low (open, or 0 to +1.5 V): Emission halt
High (Vs-2.5V to Vs) : Emission (sink current: 5 mA or less)
(Note)

Note: Vs is same voltage as the voltage of the power supply to be used.

Wiring diagram of the SF-C13 (Control category 4)

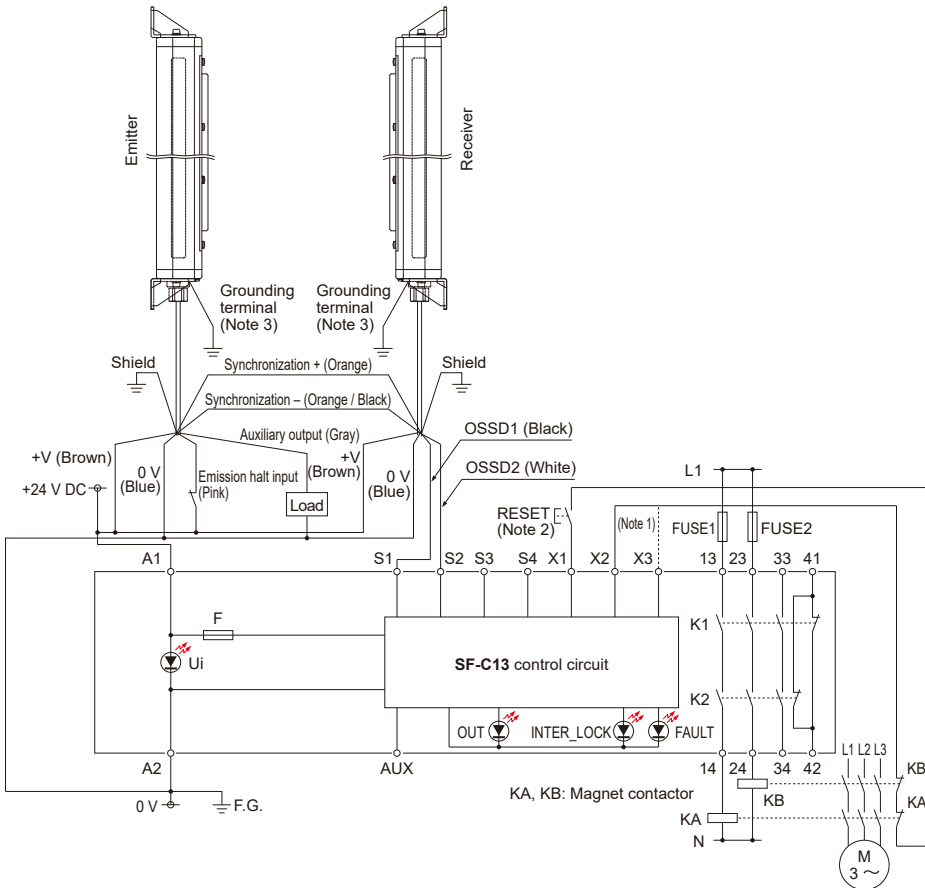

SF-C13 Terminal arrangement diagram

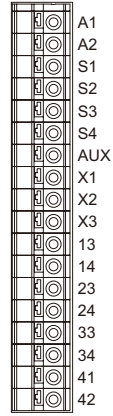

- Notes: 1) The above diagram is when using manual reset.
 If automatic reset is used, disconnect the read from X2 and connect it to X3.
 In this case, a reset (RESET) button is not needed.
 2) Use a momentary-type switch for the reset (RESET) button.
 3) Ground the grounding terminal of **BSF4-AH80** without fail.

PRECAUTIONS FOR PROPER USE



- Do not utilize this safety light curtain in “PSDI Mode”, in which the safety light curtain is utilized as an activator for machinery.
- To use this product in the U.S.A., refer to OSHA 1910. 212 and OSHA 1910. 217 for installation, and in Europe, refer to EN ISO 13855 as well. Observe your national and local requirements before installing this product.

- This catalog is a guide to select a suitable product. Be sure to read the instruction manual prior to its use.

Cautions for explosion-protection



This device has a flameproof structure and explosionproof performance that can only be ensured when the product meets all of the specified conditions and specifications. Failure to observe any of them will result in the loss of the explosionproof performance.

- Use flameproof electric appliances that are compatible with hazardous locations (locations where an explosive atmosphere of gas or vapor may exist).
- Make sure that the power supply is off while wiring. Otherwise, electric shock may result.
- Never modify or repair the product yourself. Failure to follow this instruction may result in an explosion or ignition.
- Protect the cables, or external conductors, against possible external damage by passing them through a sufficiently strong metallic tube or by other means.
- Ground the grounding terminal without fail. Failure to follow this instruction may result in an explosion or ignition.
- Do not open the lid of the flameproof enclosure, and do not remove the window frame fixtures of the enclosure. Failure to follow this instruction may result in an explosion or ignition.
- The product can be used in the areas where flameproof appliances of “Groups IIA and IIB” and temperature classification “T1 to T6” can be used, and where explosive gases may exist.
Japan: Zone 1 and Zone 2
Europe: Zone 1 and Zone 2 (Category 2G: ATEX)
USA: Class I, Zone 1 and Class I, Zone 2 (US NEC 505)
Canada: Zone 1 and Zone 2
China: Zone 1 and Zone 2
Russia: Zone 1 and Zone 2

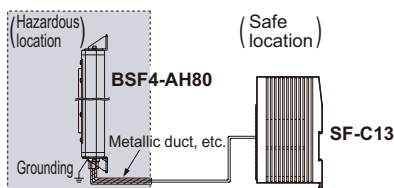

- Install the product in a location where it is less likely to suffer mechanical damage.

Mounting

- When mounting the safety light curtain, secure it in place using four M10 bolts.
- The cable lead-in port is threaded for wiring protective tube or conduit (NPT 1/2). Using a steel wire tube etc., if necessary, screw a tube into the port at least five complete threads.
- After beam alignment, tighten the hexagon-socket-head bolts for adjusting mounting angle for fixing. The recommended tightening torque is 1.5 to 1.7 N·m. (The hexagon-socket-head bolts for adjusting mounting angle are on top and bottom surfaces of the emitter and receiver.)

Grounding

- Ground the external grounding terminal on the flameproof enclosure to keep the grounding resistance at or below 100 Ω.
- For grounding, use an electric wire with equivalent or higher insulation performance to a 600 V polyvinyl-insulated electric wire, and of a thickness ensuring safe carrying of the expected maximum ground current.

Others

- This device has been developed / produced for industrial use only.
- Use the device according to the specifications of this product. Failure to follow this instruction may result in electric shock, injuries, or damage to the product.
- Unpack the product with the right side facing up. If you do not follow this instruction, you may get injured.
- Do not touch any terminals when measuring the insulation resistance. Failure to follow this instruction may result in electric shock.
- If there is something abnormal with the product, immediately turn OFF the product. Otherwise, electric shock, injuries, or a fire may result.
- Before measuring the insulation resistance, confirm that there is no explosive atmosphere of gases or vapor around. Failure to follow this instruction may result in an explosion or ignition.
- Do not place anything in front of the nameplate.
- Do not remove the nameplate.

Disclaimer

The applications described in the catalog are all intended for examples only. The purchase of our products described in the catalog shall not be regarded as granting of a license to use our products in the described applications. We do NOT warrant that we have obtained some intellectual properties, such as patent rights, with respect to such applications, or that the described applications may not infringe any intellectual property rights, such as patent rights, of a third party.

Panasonic
INDUSTRY

Panasonic Industry Co., Ltd.

Industrial Device Business Division
7-1-1, Morofuku, Daito-shi, Osaka 574-0044, Japan
industry.panasonic.com