

For detection: Non Seal Type Switches

AV3/AVM3/AVT3/AVL3 (FS/FS-T) Switches

Product Catalog

**IN Your
Future**

AV3 / AVM3 / AVT3 / AVL3 (FS / FS-T) Switches

Subminiature Size Switches with Excellent Operating Position Accuracy

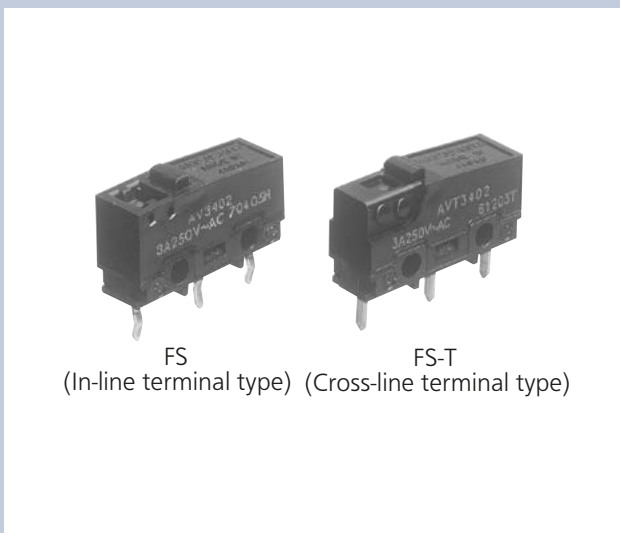

FEATURES

- Excellent operating position accuracy
- Flux-resistant construction with integrally molded terminals
- Added to former in-line terminal (AV3 / AVM3), range now includes (AVT3 / AVL3) type with cross-line terminals
- Self-standing terminal structure (AV3 / AVM3 type) with temporarily secured switch
- Series of low-level circuit type switches added to range
- Protection grade: IP40

PRODUCT TYPES TABLE

■ Combination of Operating Force (OF) and Applicable current range

Expected life	Contact	Applicable current range				Operating Force (OF)			
		1 mA	100 mA	3 A	5 A	0.25 N	0.49 N	0.98 N	1.47 N
Standard version	AgNi alloy contact			▬			Available	Available	
	CuNi alloy +AgNi alloy +Au-clad triple layer contact type (End of part No.: 61)	▬				Available	Available	Available	
	CuNi alloy +Au-clad double layer contact For low-level circuit (End of part No.: 64)	▬				Available	Available	Available	
Long life version	AgNi alloy contact			▬					Available
	CuNi alloy +AgNi alloy +Au-clad triple layer contact type (End of part No.: 61)	▬							Available
	CuNi alloy +Au-clad double layer contact For low-level circuit (End of part No.: 64)	▬							Available

ORDERING INFORMATION (PART NO.)

FS switches (In-line terminal type)

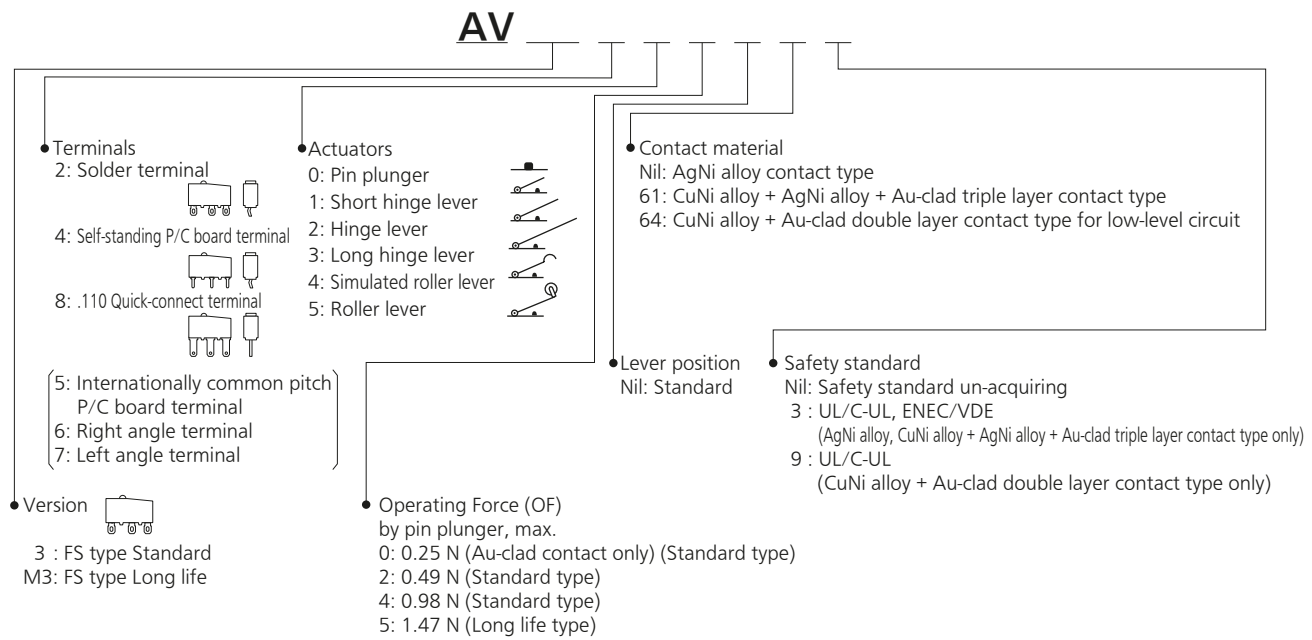

Note) 1: Since the switches of terminal of an asterisk [*] will be manufactured after an order receipt, please contact our sales representative.
 2: When ordering, please add "A" at the end of the part number.

FS-T switches (Cross-line terminal type)

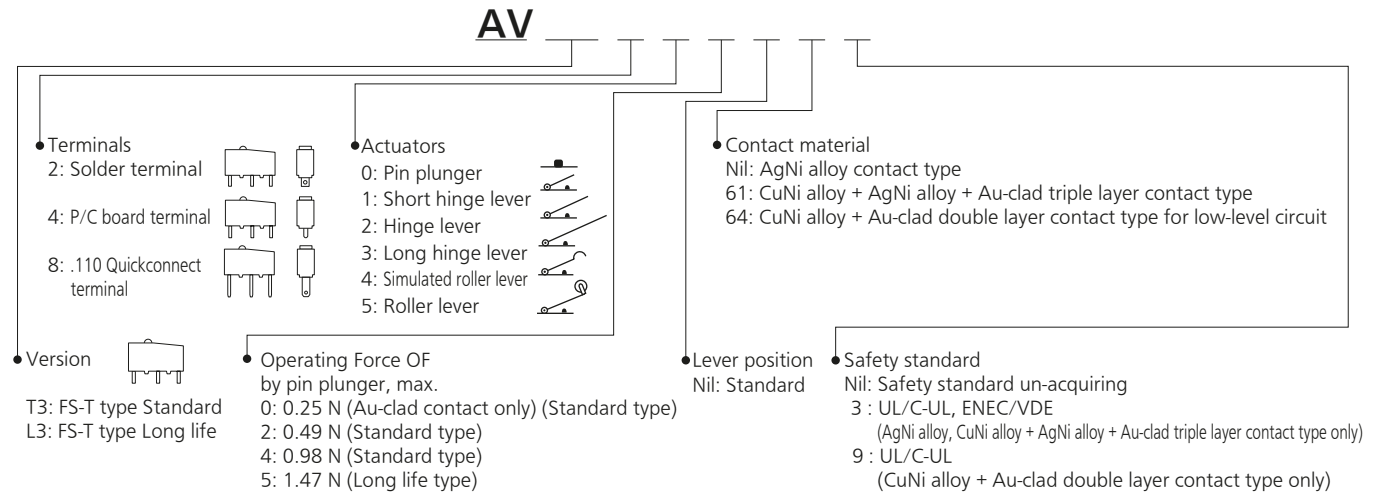

Note) When ordering, please add "A" at the end of the part number.

TYPES

■ FS type, Standard version (In-line terminal type)

1) AgNi alloy contact type

Actuator	Operating Force (OF) Max.	Part No.		
		Solder terminal	Self-standing P/C board terminal	.110 Quick-connect
Pin plunger	0.49 N	AV3202	AV3402	AV3802
	0.98 N	AV3204	AV3404	AV3804
Short hinge lever	0.20 N	AV3212	AV3412	AV3812
	0.39 N	AV3214	AV3414	AV3814
Hinge lever	0.16 N	AV3222	AV3422	AV3822
	0.34 N	AV3224	AV3424	AV3824
Long hinge lever	0.12 N	AV3232	AV3432	AV3832
	0.25 N	AV3234	AV3434	AV3834
Simulated roller lever	0.16 N	AV3242	AV3442	AV3842
	0.34 N	AV3244	AV3444	AV3844
Roller lever	0.20 N	AV3252	AV3452	AV3852
	0.39 N	AV3254	AV3454	AV3854

Note) Color of plunger is black

2) CuNi alloy +AgNi alloy +Au-clad triple layer contact type

Actuator	Operating Force (OF) Max.	Part No.		
		Solder terminal	Self-standing P/C board terminal	.110 Quick-connect
Pin plunger	0.25 N	AV320061	AV340061	AV380061
	0.49 N	AV320261	AV340261	AV380261
	0.98 N	AV320461	AV340461	AV380461
Short hinge lever	0.098 N	AV321061	AV341061	AV381061
	0.20 N	AV321261	AV341261	AV381261
	0.39 N	AV321461	AV341461	AV381461
Hinge lever	0.078 N	AV322061	AV342061	AV382061
	0.16 N	AV322261	AV342261	AV382261
	0.34 N	AV322461	AV342461	AV382461
Long hinge lever	0.12 N	AV323261	AV343261	AV383261
	0.25 N	AV323461	AV343461	AV383461
Simulated roller lever	0.16 N	AV324261	AV344261	AV384261
	0.34 N	AV324461	AV344461	AV384461
Roller lever	0.20 N	AV325261	AV345261	AV385261
	0.39 N	AV325461	AV345461	AV385461

Note) Color of plunger is red

3) CuNi alloy +Au-clad contact type, for low-level load

Actuator	Operating Force (OF) Max.	Part No.		
		Solder terminal	Self-standing P/C board terminal	.110 Quick-connect
Pin plunger	0.25 N	AV320064	AV340064	AV380064
	0.49 N	AV320264	AV340264	AV380264
	0.98 N	AV320464	AV340464	AV380464
Short hinge lever	0.098 N	AV321064	AV341064	AV381064
	0.20 N	AV321264	AV341264	AV381264
	0.39 N	AV321464	AV341464	AV381464
Hinge lever	0.078 N	AV322064	AV342064	AV382064
	0.16 N	AV322264	AV342264	AV382264
	0.34 N	AV322464	AV342464	AV382464
Long hinge lever	0.12 N	AV323264	AV343264	AV383264
	0.25 N	AV323464	AV343464	AV383464
Simulated roller lever	0.16 N	AV324264	AV344264	AV384264
	0.34 N	AV324464	AV344464	AV384464
Roller lever	0.20 N	AV325264	AV345264	AV385264
	0.39 N	AV325464	AV345464	AV385464

Notes) 1: Other types of terminals are also available. When ordering, please refer to " ORDERING INFORMATION " .

2: Color of plunger is green

For detection: Non Seal Type Switches AV3 / AVM3 / AVT3 / AVL3 (FS / FS-T) Switches

■ FS-T type Standard version (Cross-line terminal type)

1) AgNi alloy contact type

Actuator	Operating Force (OF) Max.	Part No.		
		Solder terminal	P/C board terminal	.110 Quick-connect
Pin plunger	0.49 N	AVT3202	AVT3402	AVT3802
	0.98 N	AVT3204	AVT3404	AVT3804
Short hinge lever	0.20 N	AVT3212	AVT3412	AVT3812
	0.39 N	AVT3214	AVT3414	AVT3814
Hinge lever	0.16 N	AVT3222	AVT3422	AVT3822
	0.34 N	AVT3224	AVT3424	AVT3824
Long hinge lever	0.12 N	AVT3232	AVT3432	AVT3832
	0.25 N	AVT3234	AVT3434	AVT3834
Simulated roller lever	0.16 N	AVT3242	AVT3442	AVT3842
	0.34 N	AVT3244	AVT3444	AVT3844
Roller lever	0.20 N	AVT3252	AVT3452	AVT3852
	0.39 N	AVT3254	AVT3454	AVT3854

Note) Color of plunger is black

2) CuNi alloy +AgNi alloy +Au-clad triple layer contact type

Actuator	Operating Force (OF) Max.	Part No.		
		Solder terminal	P/C board terminal	.110 Quick-connect
Pin plunger	0.25 N	AVT320061	AVT340061	AVT380061
	0.49 N	AVT320261	AVT340261	AVT380261
	0.98 N	AVT320461	AVT340461	AVT380461
Short hinge lever	0.098 N	AVT321061	AVT341061	AVT381061
	0.20 N	AVT321261	AVT341261	AVT381261
	0.39 N	AVT321461	AVT341461	AVT381461
Hinge lever	0.078 N	AVT322061	AVT342061	AVT382061
	0.16 N	AVT322261	AVT342261	AVT382261
	0.34 N	AVT322461	AVT342461	AVT382461
Long hinge lever	0.12 N	AVT323261	AVT343261	AVT383261
	0.25 N	AVT323461	AVT343461	AVT383461
Simulated roller lever	0.16 N	AVT324261	AVT344261	AVT384261
	0.34 N	AVT324461	AVT344461	AVT384461
Roller lever	0.20 N	AVT325261	AVT345261	AVT385261
	0.39 N	AVT325461	AVT345461	AVT385461

Note) Color of plunger is red

3) CuNi alloy +Au-clad double layer contact type, for low-level load

Actuator	Operating Force (OF) Max.	Part No.		
		Solder terminal	P/C board terminal	.110 Quick-connect
Pin plunger	0.25 N	AVT320064	AVT340064	AVT380064
	0.49 N	AVT320264	AVT340264	AVT380264
	0.98 N	AVT320464	AVT340464	AVT380464
Short hinge lever	0.098 N	AVT321064	AVT341064	AVT381064
	0.20 N	AVT321264	AVT341264	AVT381264
	0.39 N	AVT321464	AVT341464	AVT381464
Hinge lever	0.078 N	AVT322064	AVT342064	AVT382064
	0.16 N	AVT322264	AVT342264	AVT382264
	0.34 N	AVT322464	AVT342464	AVT382464
Long hinge lever	0.12 N	AVT323264	AVT343264	AVT383264
	0.25 N	AVT323464	AVT343464	AVT383464
Simulated roller lever	0.16 N	AVT324264	AVT344264	AVT384264
	0.34 N	AVT324464	AVT344464	AVT384464
Roller lever	0.20 N	AVT325264	AVT345264	AVT385264
	0.39 N	AVT325464	AVT345464	AVT385464

Note) Color of plunger is green

For detection: Non Seal Type Switches AV3 / AVM3 / AVT3 / AVL3 (FS / FS-T) Switches

■ FS type, Long life version (In-line terminal type)

1) AgNi alloy contact type

Actuator	Operating Force (OF) Max.	Part No.		
		Solder terminal	Self-standing P/C board terminal	.110 Quick-connect
Pin plunger	1.47 N	AVM3205	AVM3405	AVM3805
Short hinge lever	0.59 N	AVM3215	AVM3415	AVM3815
Hinge lever	0.54 N	AVM3225	AVM3425	AVM3825
Long hinge lever	0.44 N	AVM3235	AVM3435	AVM3835
Simulated roller lever	0.54 N	AVM3245	AVM3445	AVM3845
Roller lever	0.59 N	AVM3255	AVM3455	AVM3855

Note) Color of plunger is black

2) CuNi alloy +AgNi alloy +Au-clad triple layer contact type

Actuator	Operating Force (OF) Max.	Part No.		
		Solder terminal	Self-standing P/C board terminal	.110 Quick-connect
Pin plunger	1.47 N	AVM320561	AVM340561	AVM380561
Short hinge lever	0.59 N	AVM321561	AVM341561	AVM381561
Hinge lever	0.54 N	AVM322561	AVM342561	AVM382561
Long hinge lever	0.44 N	AVM323561	AVM343561	AVM383561
Simulated roller lever	0.54 N	AVM324561	AVM344561	AVM384561
Roller lever	0.59 N	AVM325561	AVM345561	AVM385561

Note) Color of plunger is red

3) CuNi alloy +Au-clad double layer contact type, for low-level load

Actuator	Operating Force (OF) Max.	Part No.		
		Solder terminal	Self-standing P/C board terminal	.110 Quick-connect
Pin plunger	1.47 N	AVM320564	AVM340564	AVM380564
Short hinge lever	0.59 N	AVM321564	AVM341564	AVM381564
Hinge lever	0.54 N	AVM322564	AVM342564	AVM382564
Long hinge lever	0.44 N	AVM323564	AVM343564	AVM383564
Simulated roller lever	0.54 N	AVM324564	AVM344564	AVM384564
Roller lever	0.59 N	AVM325564	AVM345564	AVM385564

Notes) 1: Other types of terminals are also available. When ordering, please refer to " ORDERING INFORMATION " .

2: Color of plunger is green

■ FS-T Long life version (Cross-line terminal type)

1) AgNi alloy contact type

Actuator	Operating Force (OF) Max.	Part No.		
		Solder terminal	P/C board terminal	.110 Quick-connect
Pin plunger	1.47 N	AVL3205	AVL3405	AVL3805
Short hinge lever	0.59 N	AVL3215	AVL3415	AVL3815
Hinge lever	0.54 N	AVL3225	AVL3425	AVL3825
Long hinge lever	0.44 N	AVL3235	AVL3435	AVL3835
Simulated roller lever	0.54 N	AVL3245	AVL3445	AVL3845
Roller lever	0.59 N	AVL3255	AVL3455	AVL3855

Note) Color of plunger is black

2) CuNi alloy +AgNi alloy +Au-clad triple layer contact type

Actuator	Operating Force (OF) Max.	Part No.		
		Solder terminal	P/C board terminal	.110 Quick-connect
Pin plunger	1.47 N	AVL320561	AVL340561	AVL380561
Short hinge lever	0.59 N	AVL321561	AVL341561	AVL381561
Hinge lever	0.54 N	AVL322561	AVL342561	AVL382561
Long hinge lever	0.44 N	AVL323561	AVL343561	AVL383561
Simulated roller lever	0.54 N	AVL324561	AVL344561	AVL384561
Roller lever	0.59 N	AVL325561	AVL345561	AVL385561

Note) Color of plunger is red

For detection: Non Seal Type Switches AV3 / AVM3 / AVT3 / AVL3 (FS / FS-T) Switches

3) CuNi alloy +Au-clad double layer contact type, for low-level load

Actuator	Operating Force (OF) Max.	Part No.		
		Solder terminal	P/C board terminal	.110 Quick-connect
Pin plunger	1.47 N	AVL320564	AVL340564	AVL380564
Short hinge lever	0.59 N	AVL321564	AVL341564	AVL381564
Hinge lever	0.54 N	AVL322564	AVL342564	AVL382564
Long hinge lever	0.44 N	AVL323564	AVL343564	AVL383564
Simulated roller lever	0.54 N	AVL324564	AVL344564	AVL384564
Roller lever	0.59 N	AVL325564	AVL345564	AVL385564

Note) Color of plunger is green

RATING

Contact rating

Type	Standard version				Long life version			
	AgNi alloy contact type		Au-clad contact type		AgNi alloy contact type		Au-clad contact type	
Contact specification			Triple layer contact type	Double layer contact type for low-level load			Triple layer contact type	Double layer contact type for low-level load
Type of load	Resistive load ($\cos\phi \approx 1$)	Inductive load ($\cos\phi \approx 0.6$ to 0.7)	Resistive load ($\cos\phi \approx 1$)	Inductive load ($\cos\phi \approx 1$)	Resistive load ($\cos\phi \approx 1$)	Inductive load ($\cos\phi \approx 0.6$ to 0.7)	Resistive load ($\cos\phi \approx 1$)	Inductive load ($\cos\phi \approx 1$)
125 V AC	3 A	2 A	0.1 A	—	5 A	3 A	0.1 A	—
250 V AC	3 A	2 A	0.1 A	—	5 A	3 A	0.1 A	—
30 V DC	3 A	2 A	0.1 A	0.1 A	5 A	3 A	0.1 A	0.1 A
125 V DC	0.4 A	0.05 A	—	—	0.4 A	0.05 A	—	—

Note) Time constant shall be less than 7 ms. for DC inductive loads.

Low-level circuit rating (Au-clad contact type)

Rated voltage	Resistive load
6 V DC	5 mA
12 V DC	2 mA
24 V DC	1 mA

Specifications

Item	Standard version		Long life version		Test condition	
	AgNi alloy contact type	Au-clad contact type	AgNi alloy contact type	Au-clad contact type		
Expected life	Mechanical life		Min. 5×10^5 (OT max.)		at 60 cpm	
	Electrical life		Min. 5×10^4	Min. 2×10^5		
Insulation resistance		Min. 100 M Ω			at 500 V DC	
Dielectric strength	Between non-continuous terminals		1,000 Vrms			
	Between each terminal and other exposed metal parts		1,500 Vrms			
	Between each terminal and ground		1,500 Vrms			
Contact resistance (Initial)		Max. 50 m Ω	Max. 100 m Ω	Max. 50 m Ω	Max. 100 m Ω	Ag alloy contact type: by voltage drop 1 A, 6 to 8 V DC Au-clad contact type: by voltage drop 0.1 A, 6 to 8 V DC
Vibration resistance (Pin plunger type)		10 to 55 Hz at single amplitude of 0.75 mm			Contact opening: Max. 1 ms	
Shock resistance (Pin plunger type)		294 m/s ² min (OF 0.98 N type) 147 m/s ² min (OF 0.49 N type)	294 m/s ² min (OF 0.98 N type) 147 m/s ² min (OF 0.49 N type) 49 m/s ² min (OF 0.25 N type)	Min. 294 m/s ²	Min. 294 m/s ²	Contact opening: Max. 1 ms
Allowable operating speed (no load)		0.1 to 1,000 mm/s				
Max. operating cycle rate (no load)		300 cpm				
Ambient temperature		-25 to +85°C			no freezing and condensing	
Unit weight		Approx. 2 g				
Protection grade		IP40				

Note) Test conditions and judgement are complying with " NECA C 4505 " .

For detection: Non Seal Type Switches AV3 / AVM3 / AVT3 / AVL3 (FS / FS-T) Switches

■ Operating characteristics

1) Pin plunger

4th digit number of Part No.	Operating Force (OF) Max.	Release Force (RF) Min.	Pretravel (PT) Max.	Movement Differential (MD) Max.	Overtravel (OT) Min.	Operating Position (OP)
0	0.25 N	0.020 N	0.6 mm	0.1 mm	0.4 mm	Distance from mounting holes: 8.4±0.3 mm Distance from stand-off: FS 11.8±0.4 mm FS-T 11.7±0.4 mm
2	0.49 N	0.074 N				
4	0.98 N	0.15 N				
5	1.47 N	0.20 N				

2) Short hinge lever

4th digit number of Part No.	Operating Force (OF) Max.	Release Force (RF) Min.	Pretravel (PT) Max.	Movement Differential (MD) Max.	Overtravel (OT) Min.	Operating Position (OP)
0	0.098 N	0.004 N	2.5 mm	0.5 mm	0.8 mm	Distance from mounting holes: 8.8±0.8 mm Distance from stand-off: FS 12.2±0.9 mm FS-T 12.1±0.9 mm
2	0.20 N	0.017 N				
4	0.39 N	0.034 N				
5	0.59 N	0.039 N				

3) Hinge lever

4th digit number of Part No.	Operating Force (OF) Max.	Release Force (RF) Min.	Pretravel (PT) Max.	Movement Differential (MD) Max.	Overtravel (OT) Min.	Operating Position (OP)
0	0.078 N	0.003 N	2.8 mm	0.8 mm	1.2 mm	Distance from mounting holes: 8.8±0.8 mm Distance from stand-off: FS 12.2±0.9 mm FS-T 12.1±0.9 mm
2	0.16 N	0.015 N				
4	0.34 N	0.029 N				
5	0.54 N	0.034 N				

4) Long hinge lever

4th digit number of Part No.	Operating Force (OF) Max.	Release Force (RF) Min.	Pretravel (PT) Max.	Movement Differential (MD) Max.	Overtravel (OT) Min.	Operating Position (OP)
0	—	—	3.5 mm	1.0 mm	1.6 mm	Distance from mounting holes: 8.8±1.2 mm Distance from stand-off: FS 12.2±1.3 mm FS-T 12.1±1.3 mm
2	0.12 N	0.012 N				
4	0.25 N	0.025 N				
5	0.44 N	0.029 N				

5) Simulated roller lever

4th digit number of Part No.	Operating Force (OF) Max.	Release Force (RF) Min.	Pretravel (PT) Max.	Movement Differential (MD) Max.	Overtravel (OT) Min.	Operating Position (OP)
0	—	—	2.8 mm	0.8 mm	1.2 mm	Distance from mounting holes: 11.65±0.8 mm Distance from stand-off: FS 15.05±0.9 mm FS-T 14.95±0.9 mm
2	0.16 N	0.015 N				
4	0.34 N	0.029 N				
5	0.54 N	0.034 N				

6) Roller lever

4th digit number of Part No.	Operating Force (OF) Max.	Release Force (RF) Min.	Pretravel (PT) Max.	Movement Differential (MD) Max.	Overtravel (OT) Min.	Operating Position (OP)
0	—	—	2.5 mm	0.5 mm	0.8 mm	Distance from mounting holes: 14.5±0.8 mm Distance from stand-off: FS 17.9±0.9 mm FS-T 17.8±0.9 mm
2	0.20 N	0.017 N				
4	0.39 N	0.034 N				
5	0.59 N	0.039 N				

DATA

Contact material reference chart classified by load voltage and current

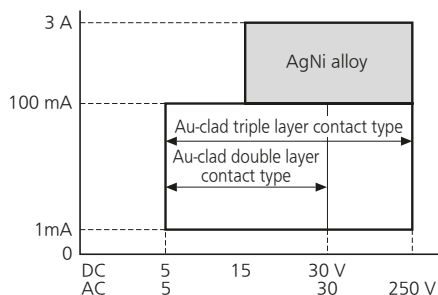

Note) If the contact is being used in the constant low-level circuit load range, the Au-clad double layer contact type is recommended. If there is a danger of the current being less than 0.5 A, for instance if the contact is being turned on and off, the Au-clad triple layer contact type is recommended.
The diagram above is intended as a reference. Please use the product within the rated voltage and current.

CONSTRUCTION

■ Standard version (FS type)

- As for FS-T switches, the terminals are the different shape.

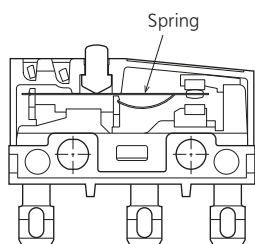

■ Long life version (FS type)

- As for FS-T switches, the terminals are the different shape.

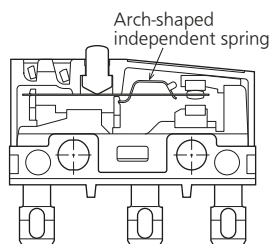

CONTACT FORM

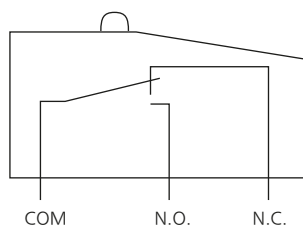

For detection: Non Seal Type Switches AV3 / AVM3 / AVT3 / AVL3 (FS / FS-T) Switches

DIMENSIONS (Unit: mm)

CAD The CAD data of the products with a " CAD " mark can be downloaded from our Website.

FS switches (In-line terminal type)

CAD

- Self-standing P/C board terminal
- Pin plunger



External dimensions

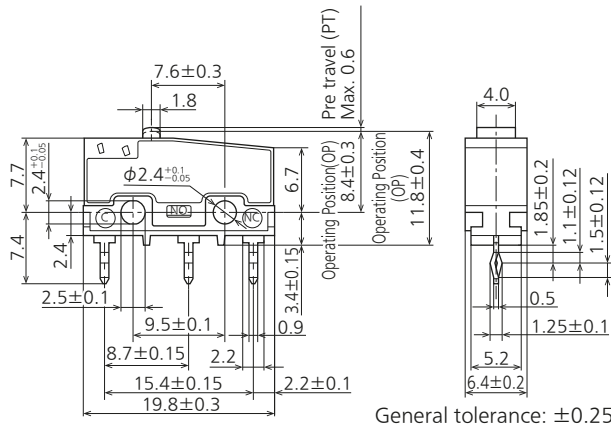

General tolerance: ±0.25

P/C board pattern

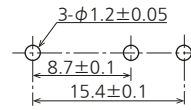

Pretravel (PT) Max.	0.6 mm	
Movement Differential (MD) Max.	0.1 mm	
Overtravel (OT) Min.	0.4 mm	
Operating Position (OP)	Distance from mounting hole	8.4±0.3 mm
	Distance from stand-off	11.8±0.4 mm

- Short hinge lever



External dimensions

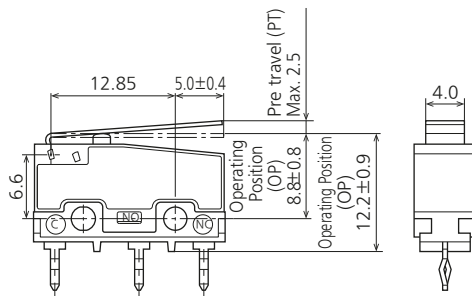

General tolerance: ±0.25

Pretravel (PT) Max.	2.5 mm	
Movement Differential (MD) Max.	0.5 mm	
Overtravel (OT) Min.	0.8 mm	
Operating Position (OP)	Distance from mounting hole	8.8±0.8 mm
	Distance from stand-off	12.2±0.9 mm

- Hinge lever



External dimensions

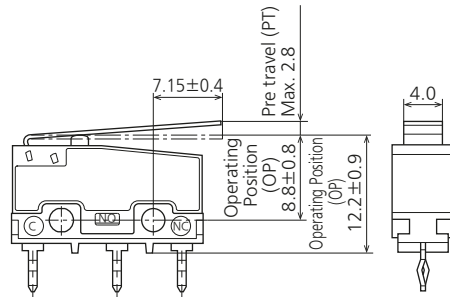

General tolerance: ±0.25

Pretravel (PT) Max.	2.8 mm	
Movement Differential (MD) Max.	0.8 mm	
Overtravel (OT) Min.	1.2 mm	
Operating Position (OP)	Distance from mounting hole	8.8±0.8 mm
	Distance from stand-off	12.2±0.9 mm

- Long hinge lever



External dimensions

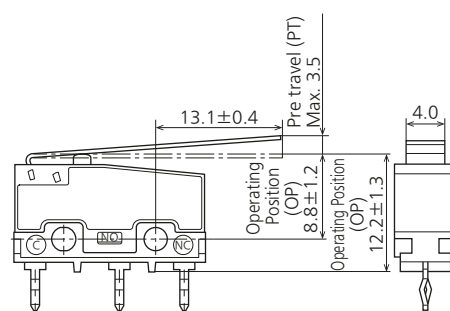

General tolerance: ±0.25

Pretravel (PT) Max.	3.5 mm	
Movement Differential (MD) Max.	1.0 mm	
Overtravel (OT) Min.	1.6 mm	
Operating Position (OP)	Distance from mounting hole	8.8±1.2 mm
	Distance from stand-off	12.2±1.3 mm

For detection: Non Seal Type Switches AV3 / AVM3 / AVT3 / AVL3 (FS / FS-T) Switches

● Simulated roller lever

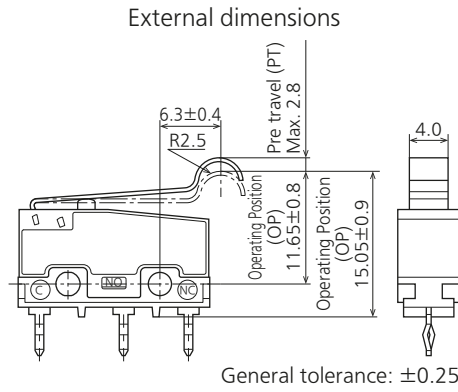
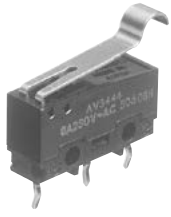

Pretravel (PT) Max.	2.8 mm	
Movement Differential (MD) Max.	0.8 mm	
Overtravel (OT) Min.	1.2 mm	
Operating Position (OP)	Distance from mounting hole	11.65 ± 0.8 mm
	Distance from stand-off	15.05 ± 0.9 mm

● Roller lever

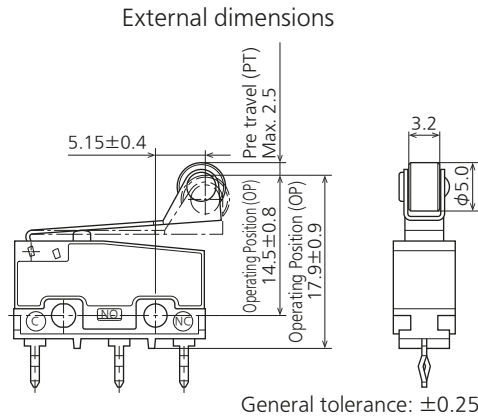

Pretravel (PT) Max.	2.5 mm	
Movement Differential (MD) Max.	0.5 mm	
Overtravel (OT) Min.	0.8 mm	
Operating Position (OP)	Distance from mounting hole	14.5 ± 0.8 mm
	Distance from stand-off	17.9 ± 0.9 mm

● Solder terminal

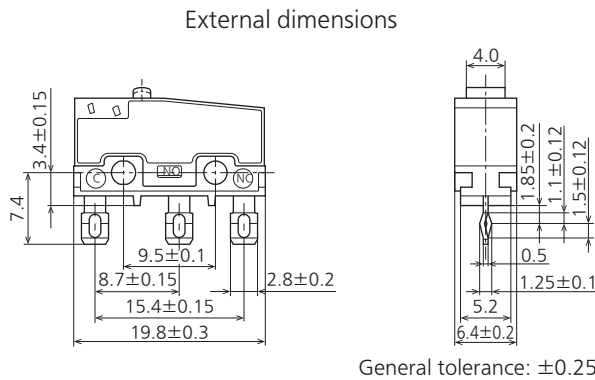

Note) Dimensions other than drawn above is same as self-standing P/C board terminal.

● .110 Quick-connect terminal

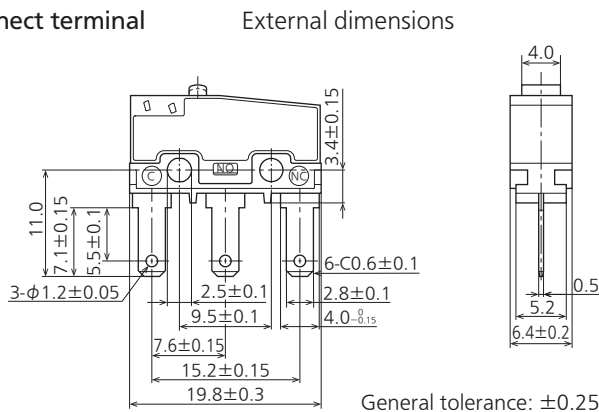

Note) Dimensions other than drawn above is same as self-standing P/C board terminal.

For detection: Non Seal Type Switches AV3 / AVM3 / AVT3 / AVL3 (FS / FS-T) Switches

FS-T switches (Cross-line terminal type)

CAD

- P/C board terminal
- Pin plunger

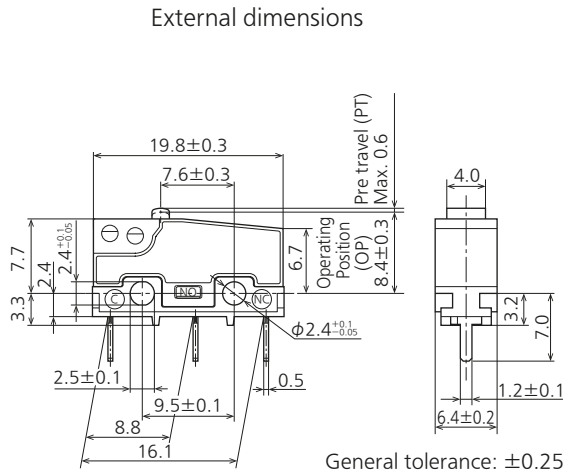

P/C board pattern

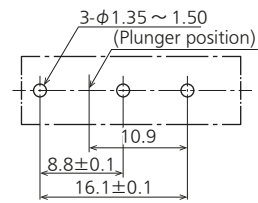

Pretravel (PT) Max.	0.6 mm	
Movement Differential (MD) Max.	0.1 mm	
Overtravel (OT) Min.	0.4 mm	
Operating Position (OP)	Distance from mounting hole	8.4 ± 0.3 mm
	Distance from stand-off	11.7 ± 0.4 mm

● Short hinge lever

External dimensions

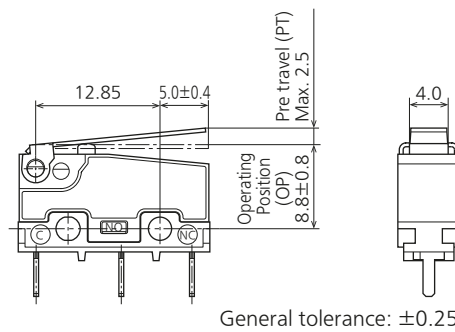
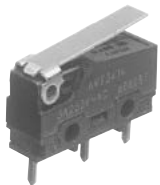

Pretravel (PT) Max.	2.5 mm	
Movement Differential (MD) Max.	0.5 mm	
Overtravel (OT) Min.	0.8 mm	
Operating Position (OP)	Distance from mounting hole	8.8 ± 0.8 mm
	Distance from stand-off	12.1 ± 0.9 mm

● Hinge lever

External dimensions

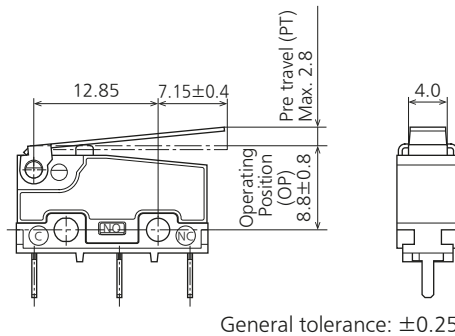

Pretravel (PT) Max.	2.8 mm	
Movement Differential (MD) Max.	0.8 mm	
Overtravel (OT) Min.	1.2 mm	
Operating Position (OP)	Distance from mounting hole	8.8 ± 0.8 mm
	Distance from stand-off	12.1 ± 0.9 mm

● Long hinge lever

External dimensions

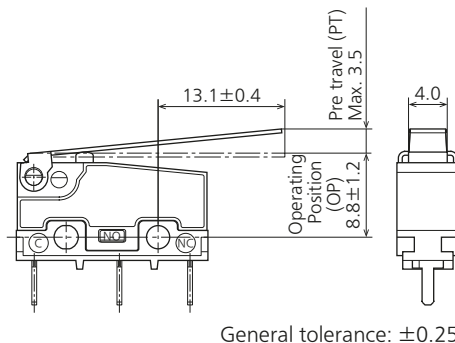
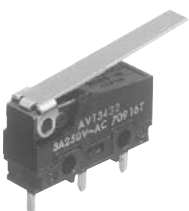

Pretravel (PT) Max.	3.5 mm	
Movement Differential (MD) Max.	1.0 mm	
Overtravel (OT) Min.	1.6 mm	
Operating Position (OP)	Distance from mounting hole	8.8 ± 1.2 mm
	Distance from stand-off	12.1 ± 1.3 mm

For detection: Non Seal Type Switches AV3 / AVM3 / AVT3 / AVL3 (FS / FS-T) Switches

● Simulated roller lever



External dimensions

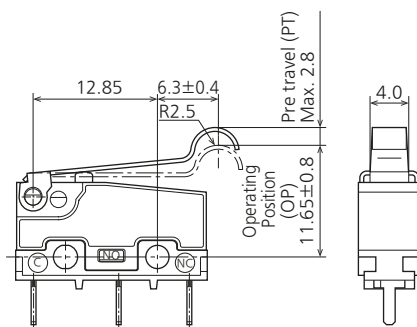

General tolerance: ±0.25

Pretravel (PT) Max.	2.8 mm	
Movement Differential (MD) Max.	0.8 mm	
Overtravel (OT) Min.	1.2 mm	
Operating Position (OP)	Distance from mounting hole	11.65±0.8 mm
	Distance from stand-off	14.95±0.9 mm

● Roller lever

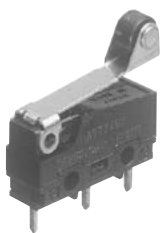

External dimensions

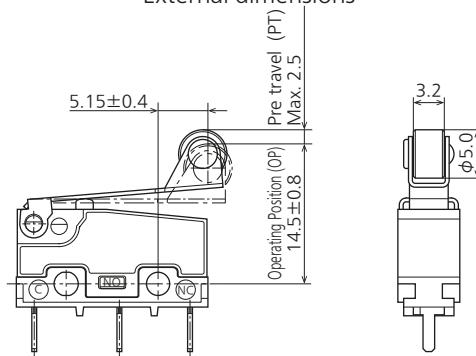

General tolerance: ±0.25

Pretravel (PT) Max.	2.5 mm	
Movement Differential (MD) Max.	0.5 mm	
Overtravel (OT) Min.	0.8 mm	
Operating Position (OP)	Distance from mounting hole	14.5±0.8 mm
	Distance from stand-off	17.8±0.9 mm

● Solder terminal



External dimensions

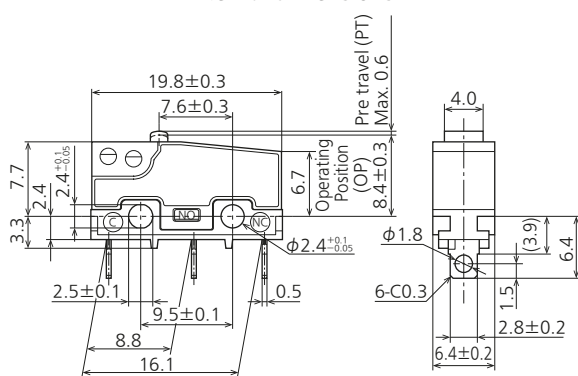

General tolerance: ±0.25

Note) As for the dimensions of lever types, dimensions other than terminals are same as P/C board terminal.

● .110 Quick-connect terminal



External dimensions

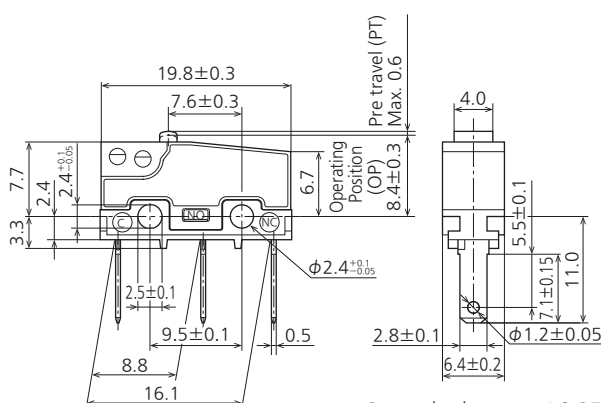

General tolerance: ±0.25

Note) As for the dimensions of lever types, dimensions other than terminals are same as P/C board terminal.

GUIDELINES FOR USAGE

Common for FS type and FS-T type

■ Regarding fastening of switch body

- 1) To secure the switch, please use an M2.3 small screw on a flat surface and tighten using a maximum torque of 0.29 N·m. Also, we recommend the use of spring washers in order to prevent loosening of the installation screws.
- 2) When the operation object is in the free position, force should not be applied directly to the actuator or pin plunger. Also force should be applied to the pin plunger from vertical direction to the switch.
- 3) In setting the movement after operation, the Overtravel OT should be set not less than 70 % as a standard.
Setting the movement at less than 70 % of OT may cause troubles such as mis-contact and welding due to small contact force of the switch.

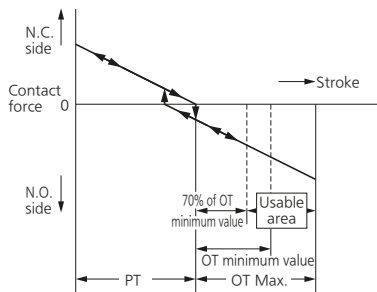

In addition, even if FS type switch actuator is pushed to full limit of operating position, it does not affect product life. However, heavy impact and excessive loading should not be applied.

■ Soldering operation

Perform soldering in less than 3 seconds with maximum 350 °C iron. Care should be taken not to apply force to the terminals during soldering. We recommend a soldering iron with temperature adjustment in order to prevent poor quality soldering.
Please consult us if you intend to use a soldering iron of 60 W or higher.

■ Environment

Locations where corrosive gases having a bad influence on contacts are present, and locations where there is an excessive amount of siliceous or other abrasive dust should be avoided.

■ Regarding connector connections (.110 quick connect terminals)

For making connections, a dedicated receptacle for 110 quick connect terminals should be used, and the terminals should be inserted parallel to the receptacle. Consideration should be given to mounting so that no tensile load is applied to the lead wires.

■ In making the switch selection

Consideration should be given to provide for no interference up to +20 % variation of the standard characteristics values.

3P CONNECTOR

(Both AV3/AVM3 subminiature switches and ABS turquoise switches)

The .110 Quick-connect terminal type of S type turquoise switches and FS type subminiature switches fit direct contact 3P connectors (Nippon Tanshi Co., Ltd.)

Reverse insertion prevention

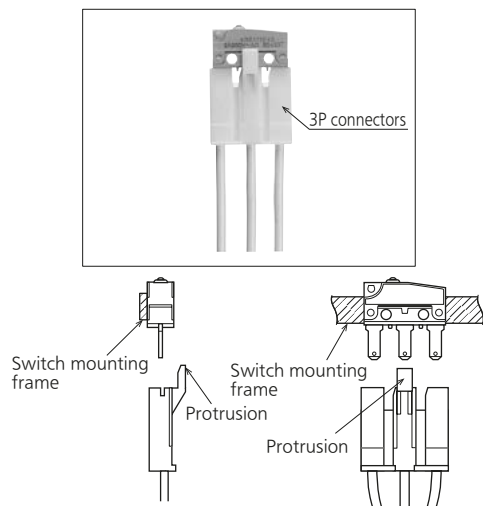

As shown in the diagram, the protrusion on the 3P connector can only be inserted on the corresponding side of the mounting frame. That is, using the plunger as a reference, the subminiature switches can only be inserted in the direction shown in the diagram: it is not possible to mount it the wrong way round.

● If you have any questions, please directly contact: Nippon Tanshi Co., Ltd.

● Product name and Product number
Product name: 3P connectors for 7.6 mm pitch subminiature switches

Product number

Name	Product number	Remark (Suitable wire)
Housing	9880-4203	—
Receptacle	171587-M2	0.3 to 0.75 mm ²

Note) Please note that Panasonic does not sell this connector.

Please refer to "the latest product specifications" when designing your product.

• Requests to customers:
<https://industrial.panasonic.com/ac/e/salespolicies/>

Technical Terminology & Cautions for Use (Detection Switches)

TECHNICAL TERMINOLOGY

■ Detection Switches

A compact switch equipped with an enclosed micro-gap snap-action contact mechanism that makes a specified motion with a specified force to open/close a circuit, and an actuator outside the enclosure (hereinafter referred to as the switch)

■ Actuator

A part of the switch that transmits the received external force to an internal spring mechanism to move the movable contact so that the switch can be opened and closed

■ Actuator stopper

A part of the switch to limit the actuator movement in the switch operation direction

■ Rated values

Values indicating the characteristics and performance guarantee standards of the snap-action switches. The rated current and rated voltage, for instance, assume specific conditions (type of load, current, voltage, frequency, etc.) .

■ Mechanical life



The service life when operated at a preset operating frequency without passing electricity through the contacts. (The life test is performed at a switching frequency of 60 times/minute and operating speed of 100 mm/second at the regular cam.)

■ Electrical life

The service life when the rated load is connected to the contact and switching operations are performed. (The life test is performed at a switching frequency of 20 times/minute and operating speed of 100 mm/second at the regular cam.)

■ Contact form

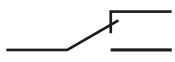
This refers to the components determining the type of application which make up the electrical input/output circuits in the contact.

SPDT	
SPST-N.C.	
SPST-N.O.	

■ Insulation resistance

Resistance between non-continuous terminals, each terminal and other exposed metal parts and between each terminal and ground.

■ Dielectric

Threshold limit value that a high voltage can be applied to a predetermined measuring location for one minute without causing damage to the insulation.

■ Contact resistance

This indicates the electrical resistance at the contact part. Generally, this resistance includes the conductor resistance of the spring and terminal portions.

■ Vibration resistance

Malfunction vibration ... Vibration range where a closed contact does not open for longer than a specified time due to vibrations during use of the snap-action switches.

■ Shock resistance

Shock durability ... Shock range where the mechanical shocks received during snap-action switches transport and installation do not damage the parts or harm the operating characteristics.

Malfunction shock ... Shock range where a closed contact does not open for longer than a specified time due to shocks during use of the snap-action switches.

Technical Terminology & Cautions for Use (Detection Switches)

TECHNICAL TERMINOLOGY

■ Definition of operating characteristic

The main terminological illustrations and meanings which are used with snap-action switches are as follows.

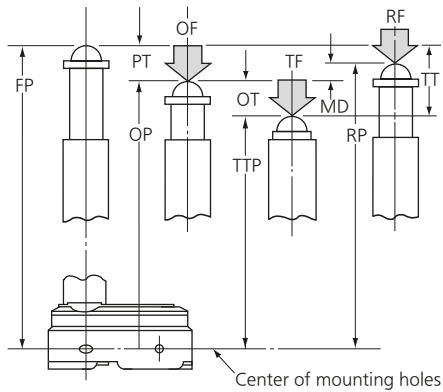

Classification	Terminology	Symbol	Unit	Varying display method	Starting current
Force	Operating Force	OF	N	Max.	The force required to cause contact snap-action. It is expressed terms of force applied to the actuator.
	Release Force	RF	N	Min.	The force to be applied to the actuator at the moment contact snaps back from operated position to total travel position.
	Total travel Force	TF	N		Force applied to an actuator required to move from an operating position to a total travel position
Movement	Pretravel	PT	mm, degree	Max.	Distance or degree of the actuator movement from free position to operating position.
	Over travel	OT	mm, degree	Min.	The distance or degree which the actuator is permitted to travel after actuation without any damage to the switching mechanism.
	Movement Differential	MD	mm, degree	Max.	The distance or degree from operating position to release position of the actuator.
	Total travel	TT	mm, degree		The migration length or the move angle from the free position to total travel position of actuator
Position	Free Position	FP	mm, degree		Position of the actuator when no force is applied to.
	Operating Position	OP	mm, degree	±	The position of the actuator when the traveling contacts snaps with the fixed contact.
	Release Position	RP	mm, degree		The position of the actuator when the traveling contacts snaps back from operating position to its original position.
	Total travel Position	TTP	mm, degree		The stopping position of the actuator after total travel.

TECHNICAL NOTES ON MECHANICAL CHARACTERISTICS

■ Actuation Force and Stroke

Adequate stroke setting is the key to high reliability. It is also important that adequate contact force be maintained to ensure high reliability. For a normally closed (N.C.) circuit, the driving mechanism should be set so that the actuator is normally in the free position. For a normally open (N.O.) circuit, the actuator should be pressed to 70 % to 100 % of the specified stroke to absorb possible errors. If the stroke is set too close to the operating point (OP), this may cause unstable contact, and in the worst case may cause actuator damage due to inertia of the drive mechanism. It is advisable that the stroke be adjusted with the mounting plate or driving mechanism.

The figure at right shows a typical example of activation and contact forces varying with stroke. In the vicinity of the OP and RP, the contact force is diminished, causing chatter and contact bounce immediately before or after reversal. For this reason, use the switch while giving due consideration to this. This also causes the snap action switch to be sensitive to vibration or shock.

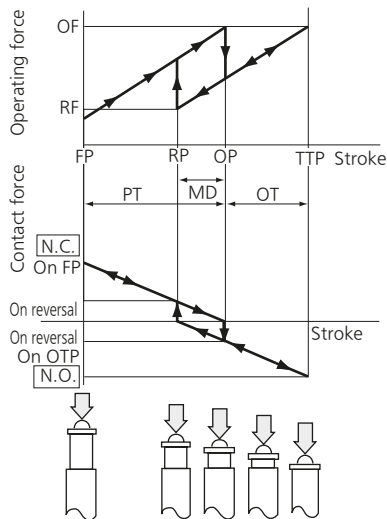

■ Changes in Operating Characteristics

Exercise design care so that malfunctions will not occur if the operating characteristics vary by as much as 20 % from, rated values.

< Example >

In the OF Max. 0.98 N specification for FS snap-action switches,
 the allowable Max. is $0.98 \text{ N} (100 \% + 20 \%) = 1.18 \text{ N}$
 In the RF Min. 0.15 N Min. specification,
 the allowable Min. is $0.15 \text{ N} (100 \% - 20 \%) = 0.12 \text{ N}$

■ Mechanical Conditions for Type Selection

Actuator type should be selected according to activation method, activation speed, activation rate, and activation frequency.

- 1) An extremely slow activation speed may cause unstable contact transfer, possibly resulting in contact failures or contact fusion.
- 2) An extremely high activation speed may cause damage to contacts or contact response failure.

■ Driving Mechanism

Use of a driving mechanism which will cause physical impact to the actuator should be avoided.

< Example >

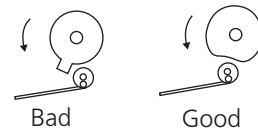

TECHNICAL NOTES ON ELECTRICAL CHARACTERISTICS

- 1) The snap-action switch is designed for AC operations. While it has small contact gaps and no arc absorber, it may be used for low-capacity DC operations. Please refer to the rating of each product
- 2) For applications with very small switching voltage or current, choose the low-level load type (Au contact) .

Small current and voltage application range (Au contact)

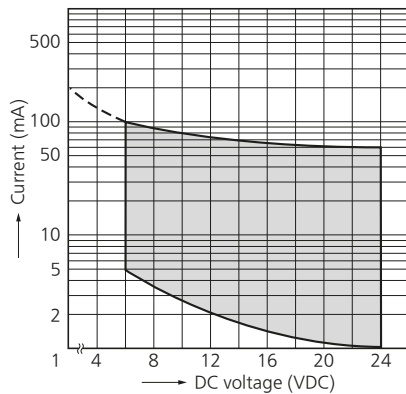

- 3) When selecting a contact type of a snap-action switch to be used for low-level load switching, the following should be noted.
 - Silver contacts' surfaces are prone to be oxidized and form a sulfide film. The switch operates with no problems at the beginning of use. However, as the contact surfaces develop films with time, the film may not be broken by the switching operation, causing a conduction failure. Therefore, please choose the Au contact type for switching a load of 0.1 A or below.
- 4) Application to Electronic Circuits
 - The snap-action switch contacts can sustain bounce or chatter when closed. Bounce or chatter can cause noise or pulse count errors when the snap action switch is used in electronic circuits.
 - If contact bounce or chatter poses problems in the vicinity of the OP and RP, use a suitable absorption network, such as a C/R network.
- 5) Check the surge current, normal current and surge duration.
- 6) Contact resistance given in performance specifications is measured with a voltage drop method using 6 to 8 V DC, 1 A (except for low-level load type). Contact resistance across COM and N.C. terminals is measured in the free position, while contact resistance across COM and N.O. terminals is measured in the total travel position.
- 7) To prevent contact welding failure, be sure to use a serial resistance for each capacitive load.
- 8) If snap-action switch operation is synchronized with the AC supply phase, this may cause: shortened electrical life, contact fusion failure, contact transfer, or other reliability problems.

Technical Terminology & Cautions for Use (Detection Switches)

CAUTIONS IN A CIRCUIT

1) Contact protection is recommended when snap-action switches are used in an inductive load circuit.

Circuit diagram	Cautions for use
<p>Contact for snap-action switch</p>	<p>(1) $r =$ more than 10Ω (2) In an AC circuit Impedance of R is to be slightly smaller than impedance of r and c.</p>
<p>Contact for snap-action switch</p>	<p>Can be used for both AC and DC. Impedance of r is nearly equal to impedance of R. C: $0.1 \mu\text{F}$</p>
<p>Contact for snap-action switch</p>	<p>(1) For DC circuits only.</p>
<p>Contact for snap-action switch</p>	<p>Can be used for both AC and DC.</p>

2) Do not connect the contacts on individual switches to different type or different poles of the power supply. Examples of power supply connections (connection to different poles)

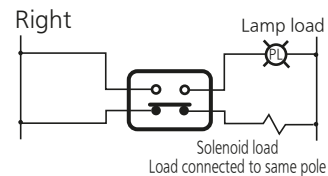
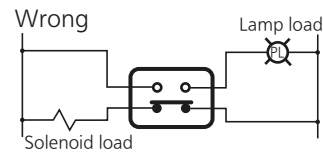

Example of wrong power supply connection (connection to different poles of power supply)
 This may lead to mixed DC and AC.

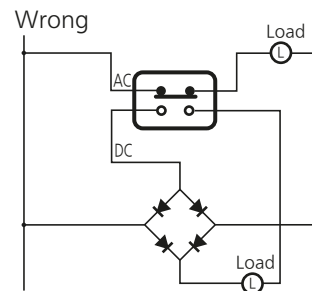

3) Avoid circuits which apply voltage between contacts. (This may lead to mixed deposition.)

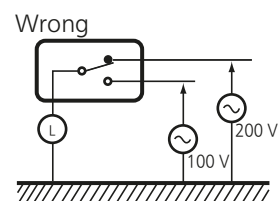

Technical Terminology & Cautions for Use (Detection Switches)

MOUNTING STATE AND ENVIRONMENT

■ Checking the insulation distance

After mounting and wiring, check the insulation distance between terminals and the ground. If the insulation distance is inadequate, mount insulating material between as required.

■ Fastening the snap-action switch body

See the Section " CAUTIONS FOR USE " for the individual switch.

■ Position adjustment with effector

- 1) The effector should be positioned so that direct force is not applied to the plunger or actuator in its free position. The operating force to the plunger should only be applied in a perpendicular direction.
- 2) Note that the use of the switch as a stopper may cause an operational problem.

■ Switch installation position

- Basically, the switch should be installed so that the object to press the switch's plunger or lever can press it down to 70 to 100 % of OT of the switch. When determining the position, the tolerance of OP (Operating Position) and other factors should be taken into account. The following describes the case where the strictest tolerance conditions are adopted.
- Example: Hinge lever type FS switch
Reference values: OP = 8.8 ± 0.8 mm
PT = Max. 2.8 mm
OT = Min. 1.2 mm

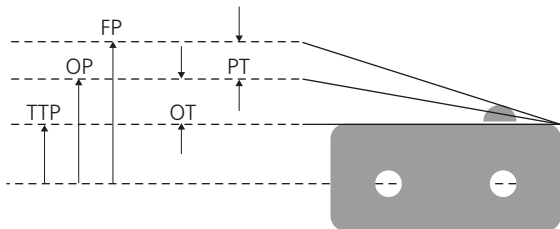

- ① When the switch is not pressed
The object to press the lever should not be in contact with the lever.
For this purpose, the object should be at a distance from the switch fater than the maximum FP (Free Position) value.
 $FP \text{ Max} = OP \text{ Max} + PT \text{ Max} = 9.6 + 2.8 = 12.4 \text{ mm Max}$
The object should be at a distance of 12.4 mm or more from the mounting hole.
- ② Depressed position
The plunger/lever should be pressed down to 70 % or more of OT (Over Travel). Therefore, the depressed position should be calculated based on the minimum value of OP (Operating Position) and the 70 and 100 % of the OT value.
 $OP \text{ Min} - 70 \% \text{ of OT} = 8.0 - 0.84 = 7.16 \text{ mm}$
 $OP \text{ Min} - 100 \% \text{ of OT} = 8.0 - 1.2 = 6.80 \text{ mm}$
The plunger/lever should be pressed down to the position of 6.80 to 7.16 mm from the mounting hole.

■ Soldering precautions

For manual soldering, lay the terminals flat (horizontal with the ground) and quickly perform the soldering operation using a soldering iron with the appropriate heat capacity and the proper amount of solder. Take care that the flux does not flow into the switch interior by using a ventilation fan to discharge flux gas and to prevent contact of the switch body with the soldering iron tip.
Be careful not to apply force to the lead wires or the terminal portions immediately after soldering.
The temperature setting and time conditions vary depending on the product.
See the section " CAUTIONS FOR USE " for each product.

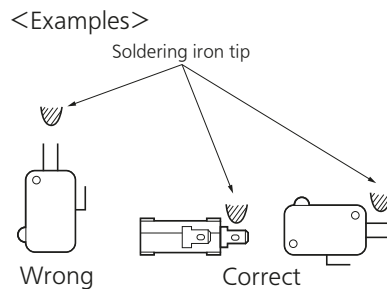

■ Avoid using in a silicon atmosphere*

Avoid using organic silicon rubber, adhesives, sealing compounds, oil, grease, and wires in a silicon atmosphere.

■ Please consult us when using under the following conditions*

- 1) Environments where hydrogen sulfide or other corrosive gases are present.
- 2) Environments where gasoline, thinner or other flammable, explosive gases are present.
- 3) Dusty environments (for non-seal type snap action switches).
- 4) The perpendicular operating speed exceeds the allowable operating speed.
- 5) Switching between different poles.
- 6) Use in environments not in the prescribed temperature or humidity range.

* Select contact sulfurization (clipping) prevention products (FS and Au-clad double layer contacts) for use with extremely small loads or an environment-resistant Turquoise switch.

■ Storage precautions

To prevent discoloration due to sulfurization of the terminals (silver-plated), store the switches in a polyethylene bag or other suitable airtight container.

Technical Terminology & Cautions for Use (Detection Switches)

■ Usage, storage, and transport conditions (except turquoise switches)

During usage, storage, or transportation, avoid locations subject to direct sunlight and maintain normal temperature, humidity, and pressure conditions.

The allowable specifications for environments suitable for usage, storage, and transportation are given below.

- 1) Temperature: The allowable temperature range differs for each switch, so refer to the switch's individual specifications. In addition, when transporting or storing switches while they are tube packaged, there are cases when the temperature may differ from the allowable range. In this situation, be sure to consult the individual specifications.
- 2) Humidity: The allowable humidity range differs for each switch, so refer to the switch's individual specifications.
- 3) Pressure: 86 to 106 kPa
The humidity range varies with the temperature. Use within the range indicated in the graph below.

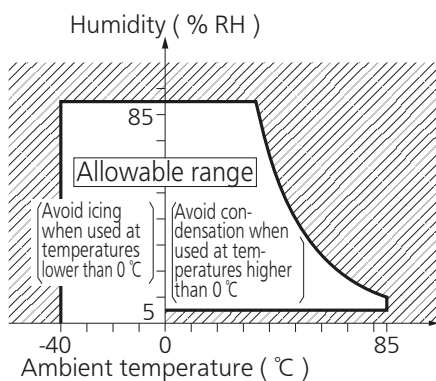

(The allowable temperature depends on the switch.)

- Condensation will occur inside the switch if there is a sudden change in ambient temperature when used in an atmosphere of high temperature and high humidity. This is particularly likely to happen when being transported by ship, so please be careful of the atmosphere when shipping. Condensation is the phenomenon whereby steam condenses to cause water droplets that adhere to the switch when an atmosphere of high temperature and humidity rapidly changes from a high to low temperature or when the switch is quickly moved from a low humidity location to one of high temperature and humidity. Please be careful because condensation can cause adverse conditions such as deterioration of insulation, coil cutoff, and rust.
- Condensation or other moisture may freeze on the switch when the temperature is lower than 0 °C 32 °F. This causes problems such as sticking of movable parts or operational time lags.
- The plastic becomes brittle if the switch is exposed to a low temperature, low humidity environment for long periods of time.
- Storage for extended periods of time (including transportation periods) at high temperatures or high humidity levels or in atmospheres with organic gases or sulfide gases may cause a sulfide film or oxide film to form on the surfaces of the contacts and/ or it may interfere with the functions. Check out the atmosphere in which the units are to be stored and transported.
- In terms of the packing format used, make every effort to keep the effects of moisture, organic gases and sulfide gases to the absolute minimum.

■ We reserve the right to modify without notice the materials, internal components, and other parts to improve product quality.





■ Handling precautions

When handling the switches, be careful not to drop them on the floor since this may damage them.

■ Others

- 1) Failure modes of switches include short-circuiting, open circuiting and temperature rises. If this switch is to be used in equipment where safety is a prime consideration, examine the possible effects of these failures on the equipment concerned, and ensure safety by providing protection circuits or protection devices. In terms of the systems involved, make provision for redundancy in the design and take steps to achieve safety design.
- 2) The ambient operating temperature (and humidity) range quoted is the range in which the switch can be operated on a continuous basis: it does not mean that using the switch within the rating guarantees the durability performance and environment withstanding performance of the switch. For details on the performance guarantee, check the specifications of each product concerned.

Technical Terminology & Cautions for Use (Detection Switches)

Shape	Classification	Pretravel (PT)	Overtravel (OT)	Operating Force (OF)	Vibration Shock	Features
	Pin plunger	Small	Small	Large	Outstanding	Appropriate for linear short-stroke action. Pin plunger acts directly on snap action mechanism, enabling high-precision positioning. Amount of movement after operation is smallest among all of the actuators, however, so reliable stopper is required.
	Hinge lever	Large	Medium	Small	Possible	Little force required for operation. Appropriate for use with low-speed cams and dogs; has large stroke. Lever available in various shapes to fit operating unit.
	Simulated roller lever	Large	Medium	Small	Possible	Tip of hinge lever is bent into a semi-circle, enabling use as a simple roller type.
	Leaf lever	Large	Large	Small	Excellent	Play in lever is used to assure maximum stroke. Construction provides for space where lever is attached, for outstanding resistance to freezing.
	Hinge roller lever	Large	Medium	Small	Possible	This is a hinge lever with a roller, and can be used with high-speed cams and dogs. The force required for pin plunger action is lighter than that of the lever, and the stroke is longer.

■ Global Sales Network Information: industrial.panasonic.com/ac/e/salesnetwork

Panasonic
INDUSTRY

Panasonic Industry Co., Ltd.

Electromechanical Control Business Division

■ 1006, Oaza Kadoma, Kadoma-shi, Osaka 571-8506, Japan
industrial.panasonic.com/ac/e/