

PAN1762

Bluetooth Low Energy Module

Product Specification

Rev. 1.2

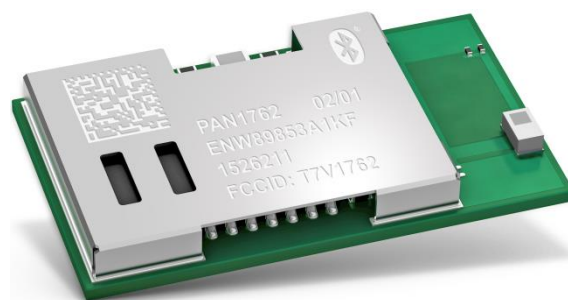

Overview

The PAN1762 is a Panasonic Bluetooth® 5.0 Low Energy (LE) module based on the Toshiba TC35680 single-chip controller.

Features

- Small SMD module: 15.6 mm x 8.7 mm x 1.9 mm
- Same form factor and pinout as PAN1026A and PAN1760A
- Bluetooth LE 5.0 compliant
- Bluetooth stack in ROM
- 128 kB flash memory available for application
- Max. 51 kB RAM for application code and ROM patches
- Host mode and stand-alone mode operation, AT command mode (soon)
- Standard SIG Bluetooth LE profiles as well as SPP over Bluetooth LE profile
- 18 General Purpose I/Os, which are shared by 2 SPI, 2 I²C, 2 UART, 4 PWM, 5 ADC, and Wake-Up inputs
- Toshiba TC35680 featuring ARM® Cortex®-M0 with SWD interface

Bluetooth

- 2 Mbps high-speed PHY, LE long range coded PHY
- LE advertising extensions (advertising on 40 channels)
- Channel selection algorithm #2
- LE secure connections
- Advertising function without CPU Wake-Up and interaction

Characteristics

- Typical sensitivity -95 dBm @ 1 Mb/s and -105 dBm @ 125 kb/s
- Output power max. 8 dBm
- Typical current consumption of 11 mA in TX (@ 8 dBm) and 5.1 mA in RX mode
- Voltage range: 1.9 V to 3.6 V
- Temperature range: -40 °C to 85 °C

Block Diagram

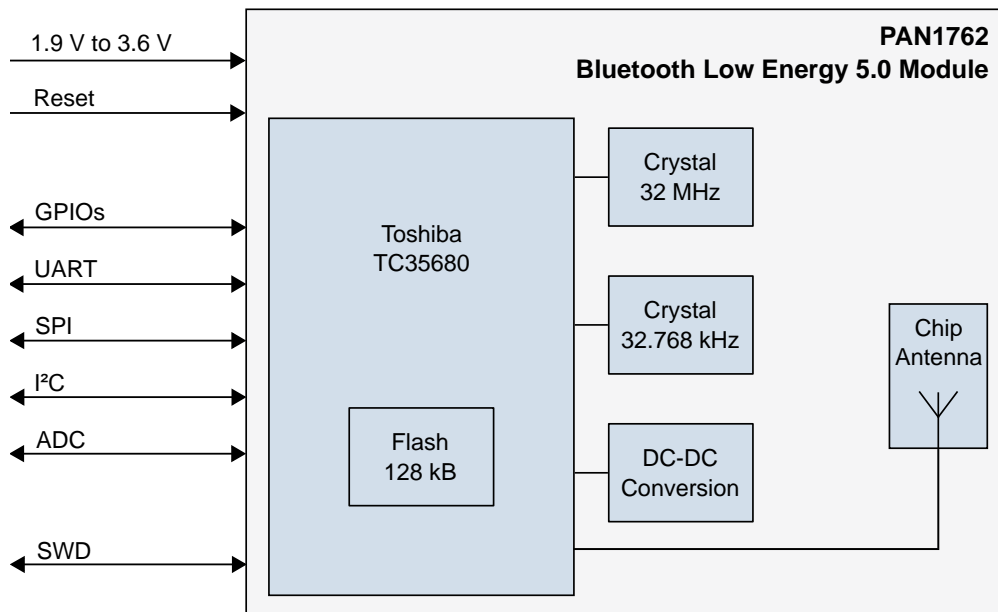

By purchase of any of the products described in this document the customer accepts the document's validity and declares their agreement and understanding of its contents and recommendations. Panasonic reserves the right to make changes as required at any time without notification. Please consult the most recently issued Product Specification before initiating or completing a design.

© Panasonic Industrial Devices Europe GmbH 2019.

This specification sheet is copyrighted. Reproduction of this document is permissible only if reproduction is without alteration and is accompanied by all associated warranties, conditions, limitations, and notices. Do not disclose it to a third party.

All rights reserved.

This Product Specification does not lodge the claim to be complete and free of mistakes.

Engineering Samples (ES)

If Engineering Samples are delivered to the customer, these samples have the status "Engineering Samples". This means that the design of this product is not yet concluded. Engineering Samples may be partially or fully functional, and they may differ from the published Product Specification.

Engineering Samples are not qualified and they are not to be used for reliability testing or series production.

Disclaimer

The customer acknowledges that samples may deviate from the Product Specification and may bear defects due to their status of development and the lack of qualification mentioned above.

Panasonic rejects any liability or product warranty for Engineering Samples. In particular, Panasonic disclaims liability for damages caused by:

- The use of the Engineering Sample other than for evaluation purposes, particularly the installation or integration in another product to be sold by the customer,
- Deviation or lapse in function of the Engineering Sample,
- Improper use of the Engineering Sample.

Panasonic Industrial Devices Europe GmbH disclaims any liability for consequential and incidental damages. In case of any queries regarding the Engineering Samples, please contact your local sales partner or the related product manager.

Table of Contents

1	About This Document	5
1.1	Purpose and Audience	5
1.2	Revision History.....	5
1.3	Use of Symbols	5
1.4	Related Documents	5
2	Overview	6
2.1	Block Diagram	7
2.2	Pin Configuration	8
2.3	UART Interface.....	10
2.4	Bluetooth Features	11
3	Detailed Description	12
3.1	Dimensions.....	12
3.2	Footprint	13
3.3	Packaging.....	14
3.4	Case Marking	17
4	Specification	18
4.1	Default Test Conditions	18
4.2	Absolute Maximum Ratings.....	18
4.3	Recommended Operating Conditions.....	19
4.4	Current Consumption.....	19
4.5	Bluetooth	20
4.6	Reliability Tests	20
4.7	Recommended Soldering Profile	21
5	Cautions	22
5.1	Design Notes	22
5.2	Installation Notes	22
5.3	Usage Condition Notes.....	23
5.4	Storage Notes.....	23
5.5	Safety Cautions	23
5.6	Other Cautions	24
5.7	Restricted Use	25
6	Regulatory and Certification Information	26
6.1	Federal Communications Commission (FCC) for US	26
6.2	Innovation, Science, and Economic Development (ISED) for Canada	28
6.3	Japanese Radio Law Compliance	30
6.4	European Conformity According to RED (2014/53/EU)	31
6.5	Bluetooth	31
6.6	RoHS and REACH Declaration	32
7	Appendix	33
7.1	Ordering Information.....	33
7.2	Contact Details	34

1 About This Document

1.1 Purpose and Audience

This Product Specification provides details on the functional, operational, and electrical characteristics of the Panasonic module PAN1762.



It is intended for hardware design, application, and Original Equipment Manufacturers (OEM) engineers.

The product is referred to as “the PAN1762” or “the module” within this document.

1.2 Revision History

Revision	Date	Modifications/Remarks
1.0	2018-11-20	Initial release
1.1	2019-05-28	Added certification and qualification information.
1.2	2019-06-03	Removed “Bluetooth SIG certified Mesh stack (soon)”

1.3 Use of Symbols

Symbol	Description
	Note Indicates important information for the proper use of the product. Non-observance can lead to errors.
	Attention Indicates important notes that, if not observed, can put the product's functionality at risk.
⇒ [chapter number] [chapter title]	Cross reference Indicates cross references within the document. Example: Description of the symbols used in this document ⇒ 1.3 Use of Symbols .

1.4 Related Documents

Please refer to the Panasonic website for related documents ⇒ [7.2.2 Product Information](#).

2 Overview

The PAN1762 is a Panasonic Bluetooth 5.0 Low Energy module based on the Toshiba TC35680 single-chip controller.

The new Bluetooth 5.0 features enable a higher symbol rate of 2 Mbps using the high-speed 2 M PHY or a significantly longer range using the Low Energy coded PHY at 500 kb/s or 125 kb/s. The new channel selection algorithm improves the performance in environments which are busy at 2.4 GHz. Furthermore, the new LE advertising extensions allow for much larger amounts of data to be broadcast in connectionless scenarios and are therefore favorable for beacon applications.

A high output power of up to 8 dBm and the industry leading sensitivity of the TC35680 in combination with the Low Energy coded PHY make the module very attractive in applications where a long range is required.

The ultra-low current consumption of the PAN1762 makes the module an ideal choice for battery powered devices. Various sleep modes can be used to minimize power consumption and prolong battery life time.

To provide maximum flexibility, the module can be operated in hosted as well as standalone mode.

In standalone mode no external processor is necessary, which saves complexity, space, and cost. The built-in 128 kB flash memory is completely free for application use.

PAN1762 shares the same small form factor and footprint as PAN1026A and PAN1760A. When migrating from PAN1760A or PAN1760 only minor code changes are required. Previously developed software, such as Bluetooth Low Energy profiles and applications, can be easily migrated with a minimal effort.

FCC, IC, MIC, and CE approval are available.

Please refer to the Panasonic website for related documents ⇒ [7.2.2 Product Information](#).

Further information on the variants and versions ⇒ [7.1 Ordering Information](#).

2.1 Block Diagram

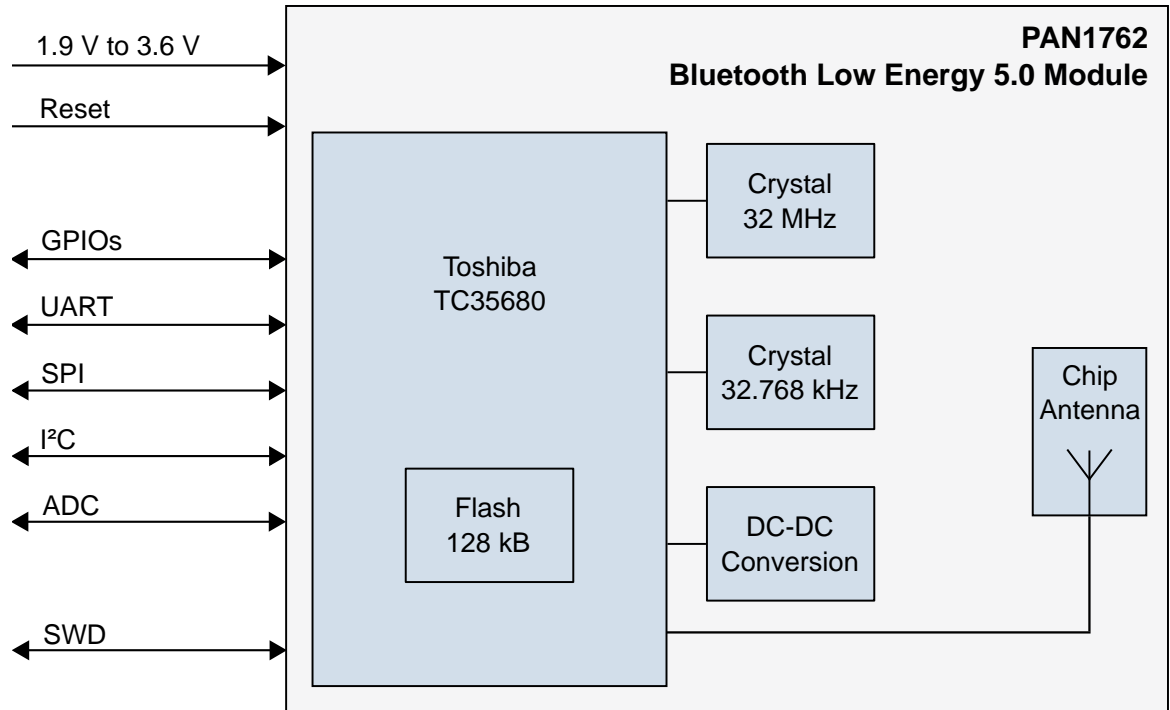

2.2 Pin Configuration

Pin Assignment

 All dimensions are in millimeters.

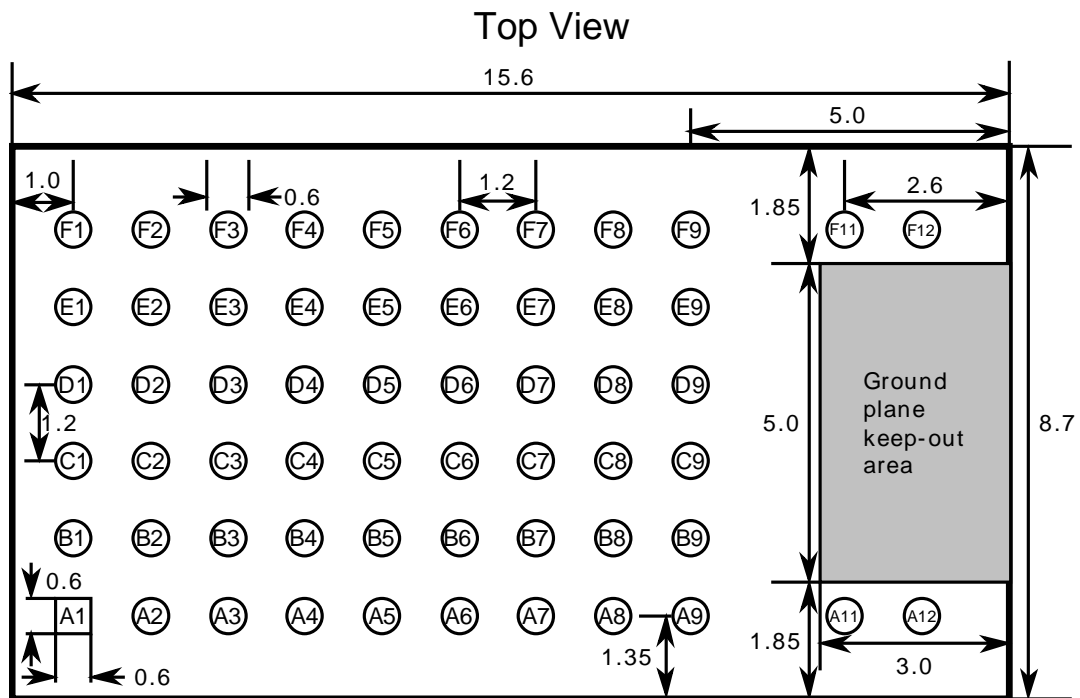

Pin Functions

No	Pin Name	Pin Type	Description
A1	GND	Ground Pin	Connect to ground
A2	GPIO3	Digital I/O	
A3	RESET	Digital Input	Reset, active low
A4	NC	NC	Not connected
A5	VCC	Power	Analog/digital power supply connection
A6	VCC	Power	Analog/digital power supply connection
A7	GND	Ground Pin	Connect to ground
A8	GPIO16	Digital I/O	
A9	GND	Ground Pin	Connect to ground
A11	GND	Ground Pin	Connect to ground

No	Pin Name	Pin Type	Description
A12	GND	Ground Pin	Connect to ground
B1	GPIO9	Digital I/O	
B2	GPIO4	Digital I/O	
B3	NC	NC	Not connected, leave open
B4	NC	NC	Not connected, leave open
B5	GPIO7/UART RTS	Digital I/O	UART RTS
B6	GPIO8/UART CTS	Digital I/O	UART CTS
B7	GPIO17	Digital I/O	
B8	NC	NC	Not connected, leave open
B9	GND	Ground Pin	Connect to ground
C1	NC	NC	Not connected, leave open
C2	NC	NC	Not connected, leave open
C3	GPIO10	Digital I/O	
C4	SWDIO	SWD	
C5	SWDCLK	SWD	
C6	GPIO1	Digital I/O	
C7	NC	NC	Not connected, leave open
C8	GND	Ground Pin	Connect to ground
C9	GND	Ground Pin	Connect to ground
D1	NC	NC	Not connected, leave open
D2	NC	NC	Not connected, leave open
D3	NC	NC	Not connected, leave open
D4	GPIO0/WakeUp0	Digital I/O	
D5	NC	NC	Not connected, leave open
D6	GPIO15/WakeUp1	Digital I/O	
D7	GND	Ground Pin	Connect to ground
D8	GND	Ground Pin	Connect to ground
D9	ANT	RF-Signal	Antenna pin (not connected for standard module version)
E1	GPIO12/SDA	Digital I/O	I2C interface
E2	GPIO11/SCL	Digital I/O	I2C interface
E3	NC	NC	Not connected, leave open

No	Pin Name	Pin Type	Description
E4	NC	NC	Not connected, leave open
E5	NC	SLPXOIN	Not connected for standard version (32 kHz clock input)
E6	GPIO6/UARTRX	Digital Input	UART RX
E7	NC	NC	Not connected, leave open
E8	GND	Ground Pin	Connect to ground
E9	GND	Ground Pin	Connect to ground
F1	GND	Ground Pin	Connect to ground
F2	NC	NC	Not connected, leave open
F3	NC	NC	Not connected, leave open
F4	NC	NC	Not connected, leave open
F5	GPIO14	Digital Input	
F6	GPIO2	Digital I/O	
F7	GPIO5/UARTTX	Digital Output	UART TX
F8	GPIO13	Digital Output	
F9	GND	Ground Pin	Connect to ground
F11	GND	Ground Pin	Connect to ground
F12	GND	Ground Pin	Connect to ground

Minimal configuration:

- VCC
- GND
- UART Rx, Tx, no flow control

2.3 UART Interface

- Default baud rate: 115 200
- Data format: 8, Stop: 1, Parity: none, LSB first
- Rx, Tx, no flow control

2.4 Bluetooth Features

- 2 Mbps high-speed PHY, Low Energy long range coded PHY
- Low Energy advertising extensions (advertising on 40 channels total)
- Channel selection algorithm #2
- Low Energy secure connections
- Advertising function without CPU Wake-Up and interaction

3 Detailed Description

3.1 Dimensions



All dimensions are in millimeters.

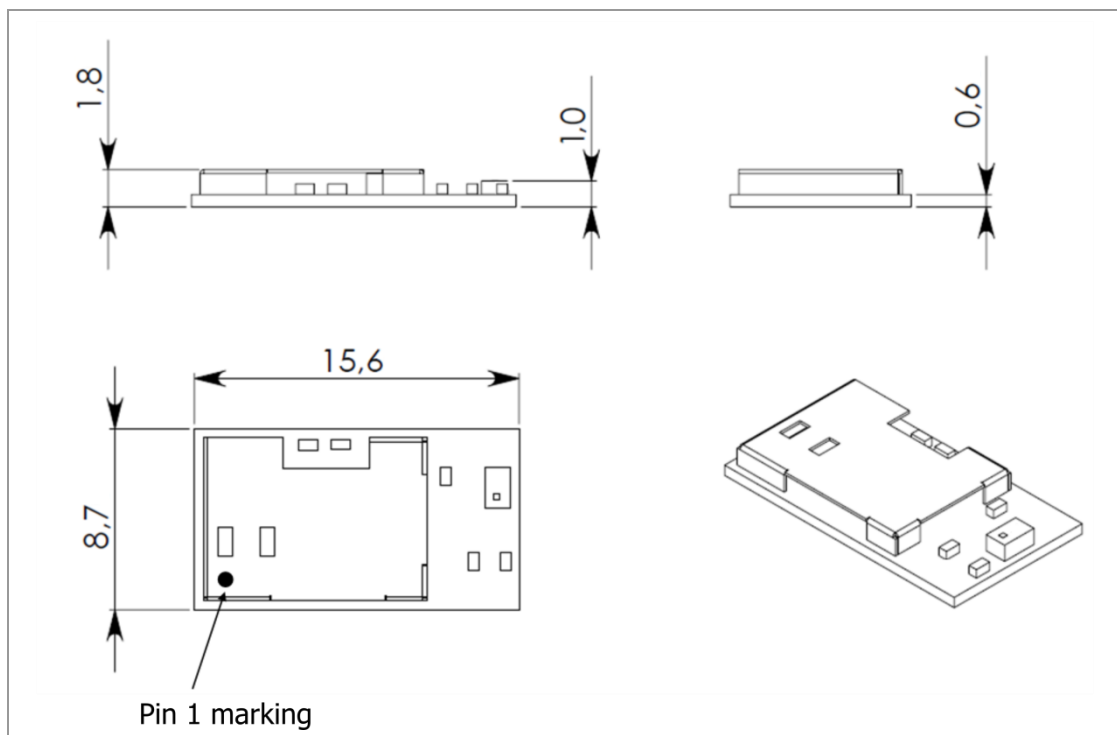

No.	Item	Dimension	Tolerance	Remark
1	Width	8.70	± 0.35	
2	Length	15.60	± 0.35	
3	Height	1.80	± 0.35	With case

3.2 Footprint



The outer dimensions have a tolerance of ± 0.35 mm.

All dimensions are in millimeters.

Top View

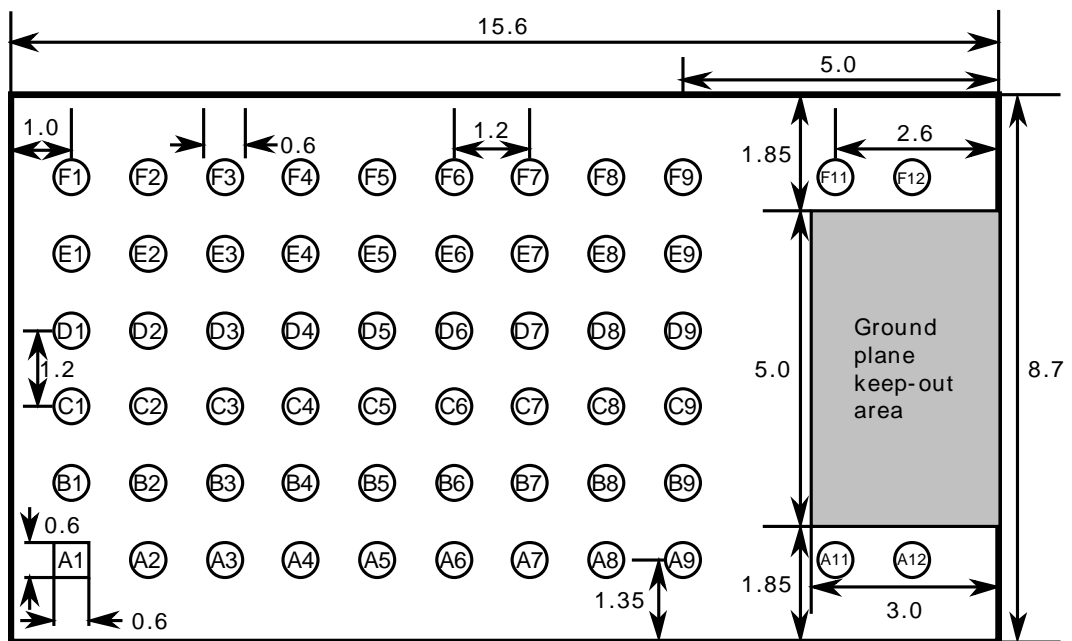

3.3 Packaging

The product is an ES status product and will be delivered in the package described below.

3.3.1 Tape Dimensions

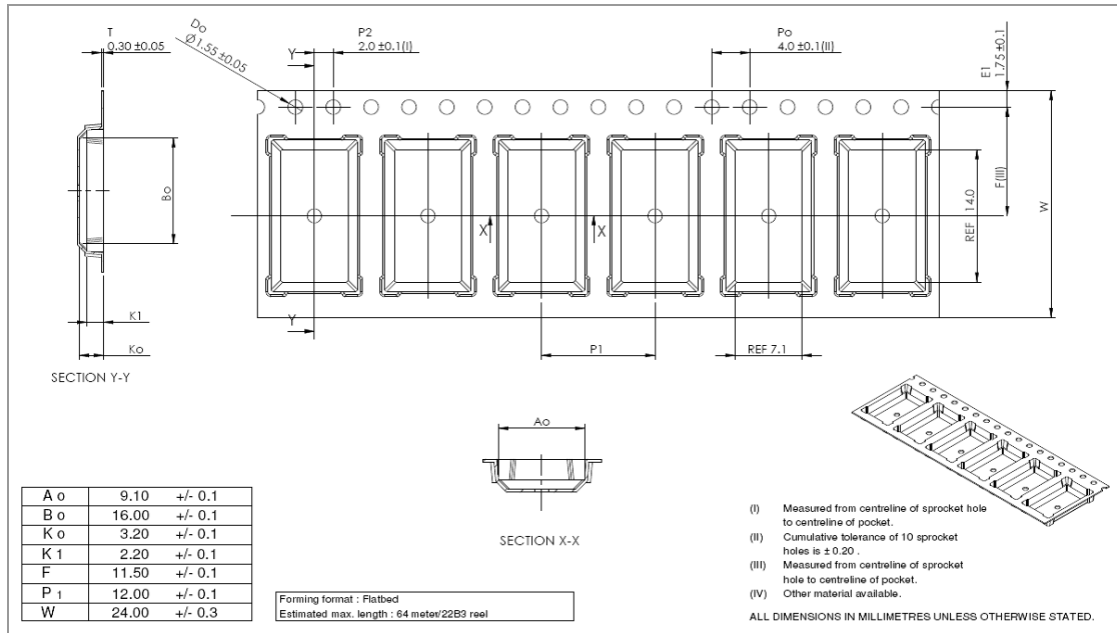

3.3.2 Packing in Tape

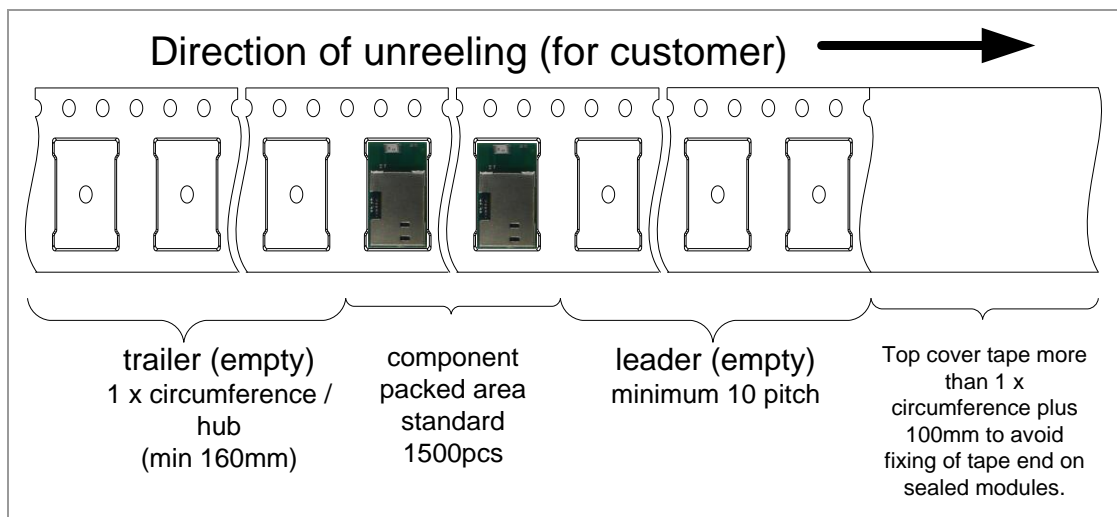

Empty spaces in the component packed area shall be less than two per reel and those spaces shall not be consecutive.

The top cover tape shall not be found on reel holes and it shall not stick out from the reel.

3.3.3 Component Direction

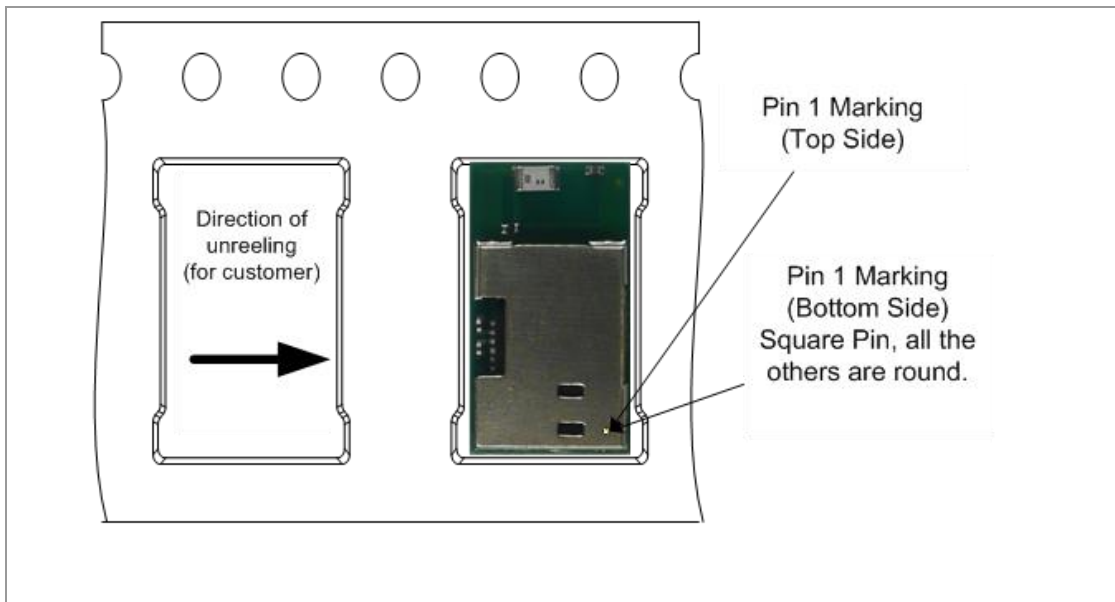

3.3.4 Reel Dimension

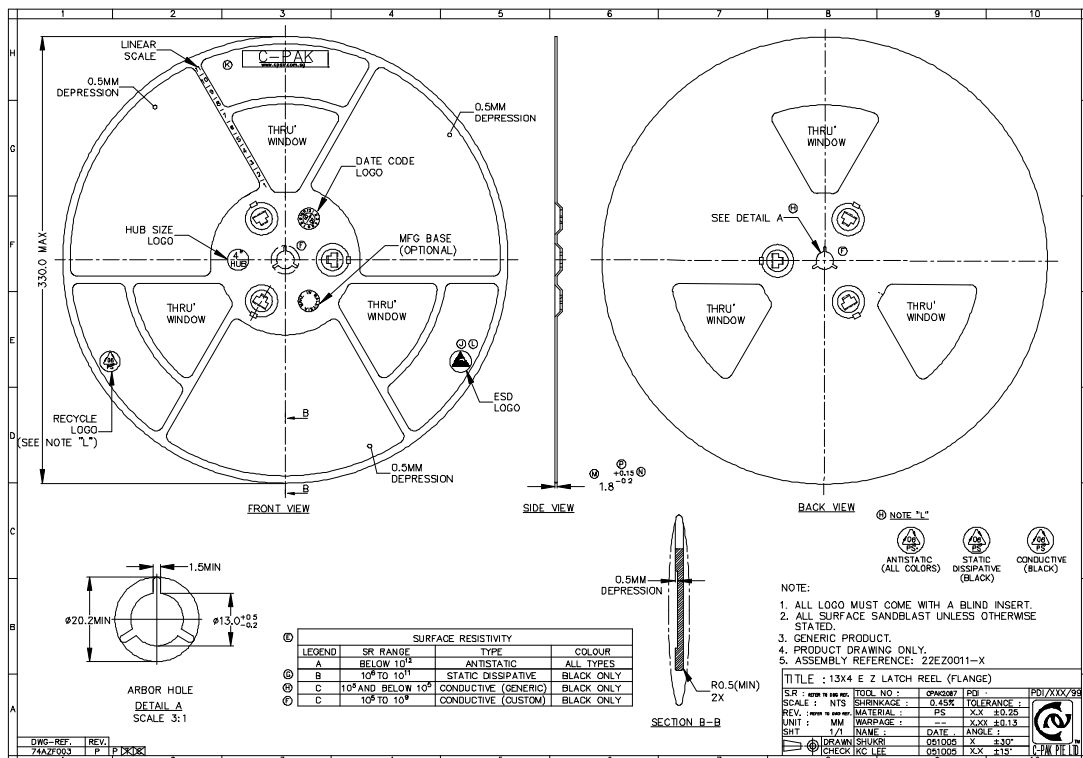

3.3.5 Package Label

Example

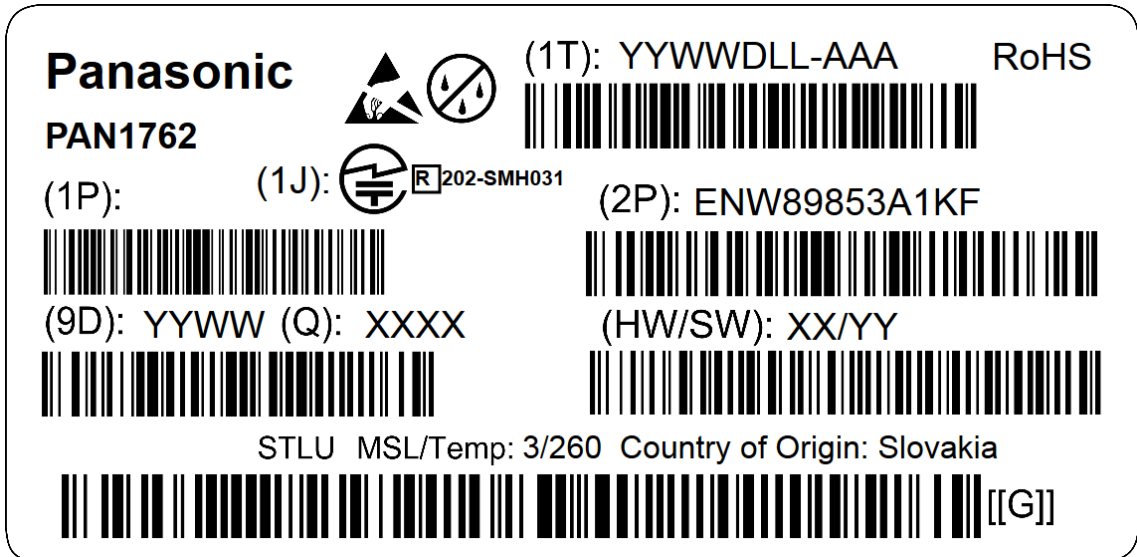

(1T)	Lot code
(1J)	MIC ID
(1P)	Customer order number, if applicable
(2P)	Order number
(9D)	Date code
(Q)	Quantity
(HW/SW)	Hardware/software version

3.3.6 Total Package

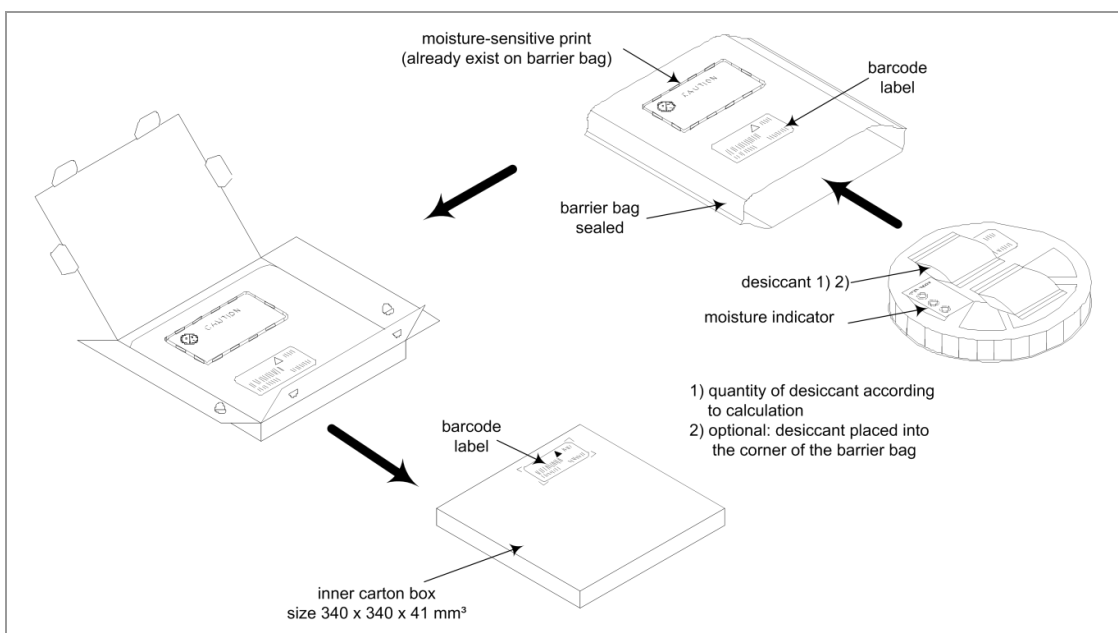

3.4 Case Marking

Example

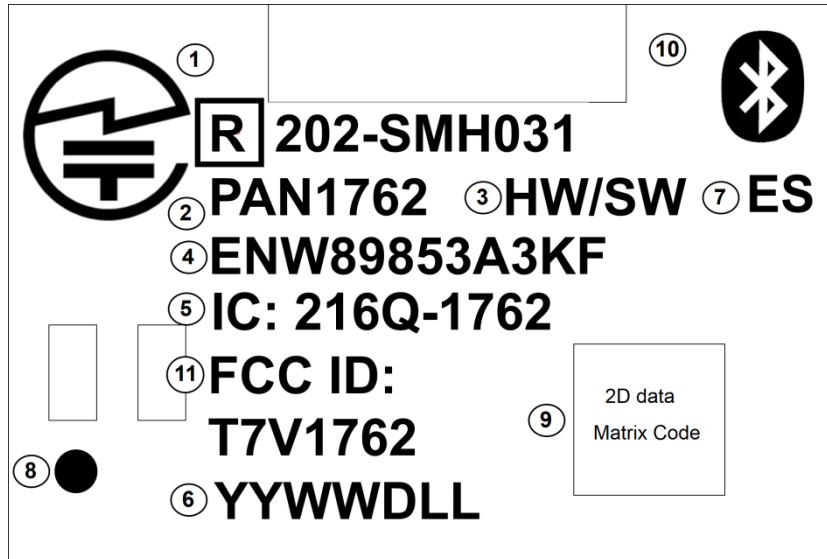

1	MIC ID
2	Brand name
3	Hardware/software version
4	Order number
5	IC ID
6	Lot code
7	Engineering Sample marking, if applicable
8	Marking for Pin 1
9	2D barcode, for internal usage only
10	Bluetooth logo
11	FCC ID

4 Specification



All specifications are over temperature and process, unless indicated otherwise.

4.1 Default Test Conditions



Temperature: 25 °C ± 10 °C
 Humidity: 40 % to 85 % RH
 Supply Voltage: 3.3 V

4.2 Absolute Maximum Ratings



The maximum ratings may not be exceeded under any circumstances, not even momentarily or individually, as permanent damage to the module may result.

Symbol	Parameter	Condition	Min.	Typ.	Max.	Units
T _{STOR}	Storage temperature		-40		85	°C
V _{DD}	Power supply		-0.3		3.9	mA
V _{ESD}	ESD robustness (Target value)	All pads, according to human body model (HBM), JEDEC STD 22, method A114			1 000	V
		According to charged device model (CDM), JEDEC STD 22, method C101			500	V
P _{RF}	RF input level				10	dBm
V _{DIG}	Voltage on any digital pins		-0.3		V _{DD} 0.3	V
I _{IN}	Input current for any digital pin		-10		10	mA

4.3 Recommended Operating Conditions



The maximum ratings may not be exceeded under any circumstances, not even momentarily or individually, as permanent damage to the module may result.

Symbol	Parameter	Condition	Min.	Typ.	Max.	Units
T _A	Ambient operating temperature range		-40		85	°C
V _{DD}	3V3 Supply voltage		1.8	3.3	3.6	V

4.4 Current Consumption



The current consumption depends on the user scenario, on the setup, and timing in the power modes.

Assume V_{DD} = 3.0 V, T_{amb} = 25 °C, if nothing else stated.

Parameter	Condition	Min.	Typ.	Max.	Units
Current Consumption Of The Digital Circuits At Operation	Bluetooth wireless: not used Built-in flash memory: not used		1.2		mA
Data Transmission Current Consumption	Target value, 1 Mbps, 0 dBm		5.2		mA
	Target value, 2 Mbps, 0 dBm		5.4		mA
	Target value, 1 Mbps, 8 dBm		11.3		mA
	Target value, 2 Mbps, 8 dBm		11.5		mA
Data Reception Current Consumption	Target value, 1 Mbps		5.1		mA
	Target value, 2 Mbps		5.6		mA
Current Consumption In Low Power Mode (Sleep Mode)	Power supply of CPU: on The oscillation of the sleep clock is operated. Whole of the data is retained.		2.5		μA
Current Consumption In Low Power Mode (Backup Mode)	Power supply of CPU: off The oscillation of the sleep clock is operated. Whole of the data is retained.		2.5		μA
Deep Sleep Mode	Power supply of CPU: off The oscillation of the sleep clock is stopped. No data is retained.		50		nA

4.5 Bluetooth

Parameter	Condition	Min.	Typ.	Max.	Units
Operation Frequency Range		2 402		2 480	MHz
Channel Spacing	Bluetooth LE		2		MHz
Output Power	Maximum setting, measured at module bottom pad		8		dBm
Sensitivity	1 Mbps, PER = 30.8 % at 1 500 packets with dirty Tx, 37 octets		-95		dBm
	2 Mbps, PER = 30.8 % at 1 500 packets with dirty Tx, 37 octets		-93		dBm
	500 kbps (S = 2), PER = 30.8 % at 1 500 packets with dirty Tx, 37 octets		-101		dBm
	125 kbps (S = 8), PER = 30.8 % at 1 500 packets with dirty Tx, 37 octets		-105		dBm

Symbol	Parameter	Condition	Min.	Typ.	Max.	Units
1	Spurious emissions	Conducted measurement at module RF bottom pad		<-30		dBm

4.6 Reliability Tests

The measurement should be done after the test device has been exposed to room temperature and humidity for one hour.

No.	Item	Limit	Condition
1	Variable Vibration Test	Electrical parameters should be within specification	Freq.: 20~2 000 Hz, Acc.: 17-50 G, Sweep: 8 min, 2 hours, For: XYZ axis
2	Shock Drop Test	Electrical parameters should be within specification	Drop parts on concrete from a height of 1 m for 3 times
3	Heat-Shock/ Temperature Cycling Test	Electrical parameters should be within specification	At -40 °C and 85 °C for 1 h/cycle Total = 300 cycles
4	Temperature Humidity Bias Test	Electrical parameters should be within specification	At 60 °C, 85 % r.H., 300 h
5	Low Temperature Storage Life Test	Electrical parameters should be within specification	At -40 °C, 300 h
6	High Temperature Storage Life Test	Electrical parameters should be within specification	At 85 °C, 300 h

4.7 Recommended Soldering Profile



- Reflow permissible cycles: 2
- Due to module weight, opposite side reflow is prohibited.
- More than 75 percent of the soldering area shall be coated by solder.
- The soldering profiles should be adhered to in order to prevent electrical or mechanical damage.
- Soldering profile assumes lead-free soldering.

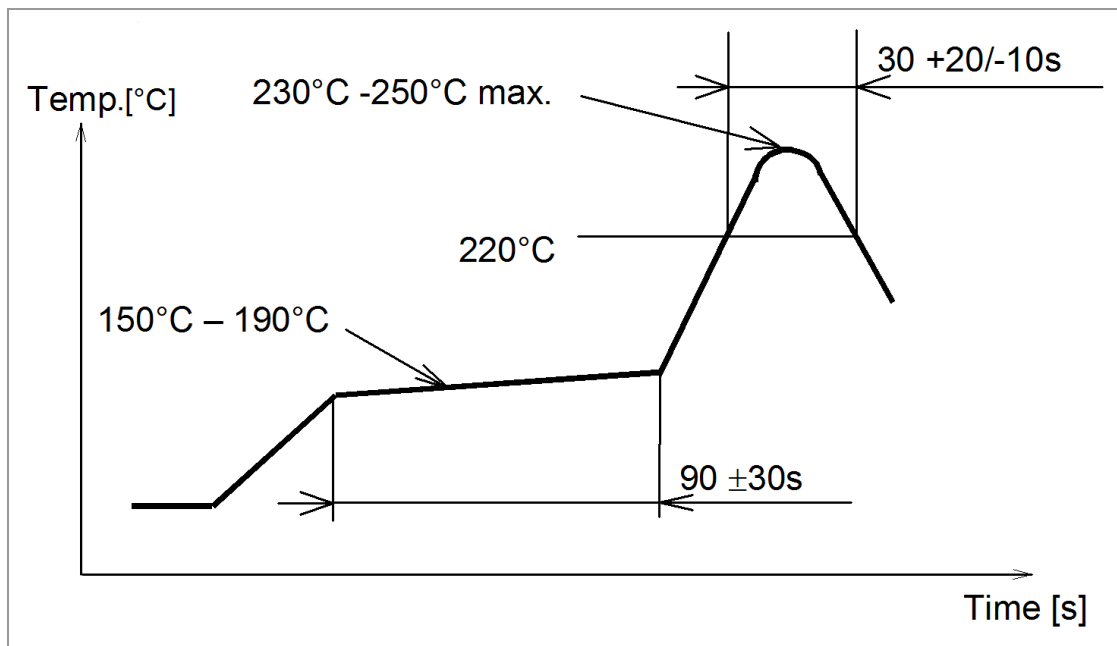

5 Cautions



Failure to follow the guidelines set forth in this document may result in degrading of the module functions and damage to the module.

5.1 Design Notes

1. Follow the conditions written in this specification, especially the control signals of this module.
2. The supply voltage should abide by the maximum ratings (⇒ [4.2 Absolute Maximum Ratings](#)).
3. The supply voltage must be free of AC ripple voltage (for example from a battery or a low noise regulator output). For noisy supply voltages, provide a decoupling circuit (for example a ferrite in series connection and a bypass capacitor to ground of at least 47 μ F directly at the module).
4. This module should not be mechanically stressed when installed.
5. Keep this module away from heat. Heat is the major cause of decreasing the life time of these modules.
6. Avoid assembly and use of the target equipment in conditions where the module temperature may exceed the maximum tolerance.
7. Keep this module away from other high frequency circuits.
8. Refer to the recommended pattern when designing a board.

5.2 Installation Notes

1. Reflow soldering is possible twice based on the conditions set forth in ⇒ [4.7 Recommended Soldering Profile](#). Set up the temperature at the soldering portion of this module according to this reflow profile.
2. Carefully position the module so that the heat will not burn into printed circuit boards or affect other components that are susceptible to heat.
3. Carefully locate the module, to avoid an increased temperature caused by heat generated by neighboring components.
4. If a vinyl-covered wire comes into contact with the module, the wire cover will melt and generate toxic gas, damaging the insulation. Never allow contact between a vinyl cover and these modules to occur.
5. This module should not be mechanically stressed or vibrated when reflowed.
6. To repair the board by hand soldering, follow the conditions set forth in this chapter.
7. Do not wash this product.
8. Pressing on parts of the metal cover or fastening objects to the metal will cause damage to the module.

5.3 Usage Condition Notes

1. Take measures to protect the module against static electricity.
If pulses or transient loads (a large load, which is suddenly applied) are applied to the modules, check and evaluate their operation before assembly of the final products.
2. Do not use dropped modules.
3. Do not touch, damage, or soil the pins.
4. Follow the recommended condition ratings about the power supply applied to this module.
5. Electrode peeling strength: Do not apply a force of more than 4.9 N in any direction on the soldered module.
6. Pressing on parts of the metal cover or fastening objects to the metal cover will cause damage.
7. These modules are intended for general purpose and standard use in general electronic equipment, such as home appliances, office equipment, information, and communication equipment.

5.4 Storage Notes

1. The module should not be stressed mechanically during storage.
2. Do not store these modules in the following conditions or the performance characteristics of the module, such as RF performance will be adversely affected:
 - Storage in salty air or in an environment with a high concentration of corrosive gas, such as Cl₂, H₂S, NH₃, SO₂, or NO_x,
 - Storage in direct sunlight,
 - Storage in an environment where the temperature may be outside the range of 5 °C to 35 °C, or where the humidity may be outside the 45 % to 85 % range,
 - Storage of the modules for more than one year after the date of delivery storage period: Please check the adhesive strength of the embossed tape and soldering after 6 months of storage.
3. Keep this module away from water, poisonous gas, and corrosive gas.
4. This module should not be stressed or shocked when transported.
5. Follow the specification when stacking packed crates (max. 10).

5.5 Safety Cautions

These specifications are intended to preserve the quality assurance of products and individual components.

Before use, check and evaluate the operation when mounted on your products. Abide by these specifications without deviation when using the products. These products may short-circuit. If electrical shocks, smoke, fire, and/or accidents involving human life are anticipated when a short circuit occurs, provide the following failsafe functions as a minimum:

1. Ensure the safety of the whole system by installing a protection circuit and a protection device.
2. Ensure the safety of the whole system by installing a redundant circuit or another system to prevent a single fault causing an unsafe status.

5.6 Other Cautions

1. Do not use the module for other purposes than those listed in section ⇒ [5.3 Usage Condition Notes](#).
2. Be sure to provide an appropriate fail-safe function on your product to prevent any additional damage that may be caused by the abnormal function or the failure of the module.
3. This module has been manufactured without any ozone chemical controlled under the Montreal Protocol.
4. These modules are not intended for use under the special conditions shown below. Before using these modules under such special conditions, carefully check their performance and reliability under the said special conditions to determine whether or not they can be used in such a manner:
 - In liquid, such as water, salt water, oil, alkali, or organic solvent, or in places where liquid may splash,
 - In direct sunlight, outdoors, or in a dusty environment,
 - In an environment where condensation occurs,
 - In an environment with a high concentration of harmful gas (e. g. salty air, HCl, Cl₂, SO₂, H₂S, NH₃, and NO_x).
5. If an abnormal voltage is applied due to a problem occurring in other components or circuits, replace these modules with new modules, because they may not be able to provide normal performance even if their electronic characteristics and appearances appear satisfactory.



Please refer to the Panasonic website for for further information
⇒ [7.2.2 Product Information](#).

5.7 Restricted Use

5.7.1 Life Support Policy

This Panasonic Industrial Devices Europe GmbH product is not designed for use in life support appliances, devices, or systems where malfunction can reasonably be expected to result in a significant personal injury to the user, or as a critical component in any life support device or system whose failure to perform can be reasonably expected to cause the failure of the life support device or system, or to affect its safety or effectiveness.

Panasonic customers using or selling these products for use in such applications do so at their own risk and agree to fully indemnify Panasonic Industrial Devices Europe GmbH for any damages resulting.

5.7.2 Restricted End Use

This Panasonic Industrial Devices Europe GmbH product is not designed for any restricted activity that supports the development, production, handling usage, maintenance, storage, inventory or proliferation of any weapons or military use.

Transfer, export, re-export, usage or reselling of this product to any destination, end user or any end use prohibited by the European Union, United States or any other applicable law is strictly prohibited.

6 Regulatory and Certification Information

6.1 Federal Communications Commission (FCC) for US

6.1.1 FCC Notice



The PAN1762 including the antennas, which are listed in [⇒ 6.1.5 Approved Antenna List](#), complies with Part 15 of the FCC Rules.

The device meets the requirements for modular transmitter approval as detailed in FCC public Notice DA00-1407. The transmitter operation is subject to the following two conditions:

1. This device may not cause harmful interference, and
2. This device must accept any interference received, including interference that may cause undesired operation.

6.1.2 Caution



The FCC requires the user to be notified that any changes or modifications made to this device that are not expressly approved by Panasonic Industrial Devices Europe GmbH may void the user's authority to operate the equipment.



This equipment has been tested and found to comply with the limits for a Class B digital device, pursuant to Part 15 of the FCC Rules.

These limits are designed to provide reasonable protection against harmful interference in a residential installation. This equipment generates uses and can radiate radio frequency energy and, if not installed and used in accordance with the instructions, may cause harmful interference to radio communications.

However, there is no guarantee that interference will not occur in a particular installation. If this equipment does cause harmful interference to radio or television reception, which can be determined by turning the equipment off and on, the user is encouraged to try to correct the interference by one or more of the following measures:

- Reorient or relocate the receiving antenna,
- Increase the separation between the equipment and receiver,
- Connect the equipment into an outlet on a circuit different from that to which the receiver is connected,
- Consult the dealer or an experienced radio/TV technician for help.

6.1.3 Label Requirements



The OEM must ensure that FCC labelling requirements are met. This includes a clearly visible label on the outside of the OEM enclosure specifying the appropriate Panasonic FCC identifier for this product as well as the FCC Notice above.

The FCC identifier is **FCC ID: T7V1762**.

This FCC identifier is valid for the PAN1762. The end product must in any case be labelled on the exterior with:

"Contains FCC ID: T7V1762"

6.1.4 Antenna Warning

This antenna warning refers to the test device with the model number PAN1762

⇒ [7.1 Ordering Information](#)

The device is tested with a standard SMA connector and with the antenna listed below. When integrated into the OEM's product, these fixed antennas require installation preventing end users from replacing them with non-approved antennas. Any antenna not in the following table must be tested to comply with FCC Section 15.203 for unique antenna connectors and with Section 15.247 for emissions. The FCC identifier for the device with the antenna listed in ⇒ [6.1.5 Approved Antenna List](#) is the same (**FCC ID: T7V1762**).

6.1.5 Approved Antenna List

Item	Part Number	Manufacturer	Frequency Band	Type	Max. Gain (dBi)
1	ANT016008LCS2442MA1	TDK	2.4 GHz	Chip antenna	1.6

6.1.6 RF Exposure



To comply with FCC RF Exposure requirements, the OEM must ensure that only antennas from the Approved Antenna List are installed ⇒ [6.1.5 Approved Antenna List](#).

The preceding statement must be included as a CAUTION statement in manuals for products operating with the approved antennas in the previous table to alert users on FCC RF Exposure compliance.

Any notification to the end user of installation or removal instructions about the integrated radio module is not allowed.

The radiated output power of the PAN1762 with a mounted ceramic antenna (**FCC ID: T7V1762**) is below the FCC radio frequency exposure limits. Nevertheless, the PAN1762 shall be used in such a manner that the potential for human contact during normal operation is minimized.

End users may not be provided with the module installation instructions. OEM integrators and end users must be provided with transmitter operating conditions for satisfying RF exposure compliance.

6.2 Innovation, Science, and Economic Development (ISED) for Canada

English

The PAN1762 is licensed to meet the regulatory requirements of ISED.

License ID: **IC: 216Q-1762**

Manufacturers of mobile, fixed or portable devices incorporating this module are advised to clarify any regulatory questions and ensure compliance for SAR and/or RF exposure limits. Users can obtain Canadian information on RF exposure and compliance from www.ic.gc.ca.

This device has been designed to operate with the antennas listed in ⇒ [6.1.5 Approved Antenna List](#), having a maximum gain of +1.6 dBi. Antennas not included in this list or having a gain greater than +1.6 dBi are strictly prohibited for use with this device. The required antenna impedance is 50 ohms. The antenna used for this transmitter must not be co-located or operating in conjunction with any other antenna or transmitter.

Due to the model size, the IC identifier is displayed in the installation instruction only and it cannot be displayed on the module's label due to the limited size.

French

PAN1762 est garanti conforme aux dispositions réglementaires d'Industry Canada (ISED).

License: **IC: 216Q-1762**

Il est recommandé aux fabricants d'appareils fixes, mobiles ou portables de consulter la réglementation en vigueur et de vérifier la conformité de leurs produits relativement aux limites d'exposition aux rayonnements radiofréquence ainsi qu'au débit d'absorption spécifique maximum autorisé.

Des informations pour les utilisateurs sur la réglementation Canadienne concernant l'exposition aux rayonnements RF sont disponibles sur le site www.ic.gc.ca.

Ce produit a été développé pour fonctionner spécifiquement avec les antennes listées dans le tableau ⇒ [6.1.5 Approved Antenna List](#), présentant un gain maximum de 1.6 dBi. Des antennes autres que celles listées ici, ou présentant un gain supérieur à 1.6 dBi ne doivent en aucune circonstance être utilisées en combinaison avec ce produit. L'impédance des antennes compatibles est 50 Ohm. L'antenne utilisée avec ce produit ne doit ni être située à proximité d'une autre antenne ou d'un autre émetteur, ni être utilisée conjointement avec une autre antenne ou un autre émetteur.

En raison de la taille du produit, l'identifiant IC est fourni dans le manuel d'installation.

6.2.1 IC Notice

English



The device PAN1762 (⇒ [7.1 Ordering Information](#)), including the antennas (⇒ [6.1.5 Approved Antenna List](#)), complies with Canada RSS-GEN Rules. The device meets the requirements for modular transmitter approval as detailed in RSS-Gen.

Operation is subject to the following two conditions:

1. This device may not cause harmful interference, and
2. This device must accept any interference received, including interference that may cause undesired operation.

French



Le présent appareil PAN1762 (⇒ [7.1 Ordering Information](#)), les antennes y compris (⇒ [6.1.5 Approved Antenna List](#)), est conforme aux CNR-Gen d'Industrie Canada applicables aux appareils radio exempts de licence.

L'exploitation est autorisée aux deux conditions suivantes:

1. L'appareil ne doit pas produire de brouillage, et
2. L'utilisateur de l'appareil doit accepter tout brouillage radioélectrique subi, même si le brouillage est susceptible d'en compromettre le fonctionnement.

6.2.2 Labeling Requirements

English



Labeling Requirements

The OEM must ensure that IC labelling requirements are met. This includes a clearly visible label on the outside of the OEM enclosure specifying the appropriate Panasonic IC identifier for this product as well as the IC Notice above.

The IC identifier is:

IC: 216Q-1762

This IC identifier is valid for all PAN1762 modules ⇒ [7.1 Ordering Information](#). In any case, the end product must be labelled on the exterior with:

"Contains IC: 216Q-1762"

French



Obligations d'étiquetage

Les fabricants d'équipements d'origine (FEO) – en anglais Original Equipment Manufacturer (OEM) – doivent s'assurer que les obligations d'étiquetage IC du produit final sont remplies. Ces obligations incluent une étiquette clairement visible à l'extérieur de l'emballage externe, comportant l'identifiant IC du module Panasonic inclus, ainsi que la notification ci-dessus.

L'identifiant IC est:

IC: 216Q-1762

Cet identifiant est valide pour tous les modules PAN1762 ⇒ [7.1 Ordering Information](#). Dans tous les cas les produits finaux doivent indiquer sur leur emballage externe la mention suivante:

"Contient IC: 216Q-1762"

6.3 Japanese Radio Law Compliance

This device is granted pursuant to the Japanese Radio Law (電波法).

This device should not be modified (otherwise the granted designation number will become invalid).

The MIC ID is: [R]202-SMH031

6.4 European Conformity According to RED (2014/53/EU)

All modules described in this Product Specification comply with the standards according to the following LVD (2014/35/EU), EMC-D (2014/30/EU) together with RED (2014/53/EU) articles:

- 3.1a Safety/Health: EN 62368-1:2014
EN 62311:2008
- 3.1b EMC: EN 301 489-1 V2.1.1:2017-02
EN 301 489-17 V3.1.1:2017-02
- 3.2 Radio: EN 300 328 V2.1.1:2016-11

As a result of the conformity assessment procedure described in 2014/53/EU Directive, the end customer equipment should be labelled as follows:



The end customer has to assure that the device has a distance of more than 20 cm from the human body under all circumstances.

The end customer equipment must meet the actual Safety/Health requirements according to RED.

PAN1762 and its model versions in the specified reference design can be used in all countries of the European Economic Area (Member States of the EU, European Free Trade Association States [Iceland, Liechtenstein, Norway]), Monaco, San Marino, Andorra, and Turkey.

6.5 Bluetooth

Bluetooth end products which integrate the PAN1762 need to receive the following IDs at creation:

Bluetooth 5.0	Declaration ID	QDID
Component (Tested)	D041739	118932
Component (Tested)	D039178	119076
End Product	D044293	121739

Bluetooth Marks

According to the Bluetooth SIG, the PAN1762 fulfills the criteria to label your product as a Bluetooth device:



For further information please refer to the Bluetooth website www.bluetooth.com.

6.6 RoHS and REACH Declaration

The latest declaration of environmental compatibility (Restriction of Hazardous Substances, RoHS and Registration, Evaluation, Authorisation and Restriction of Chemicals, REACH) for supplied products can be found on the Panasonic website in the section “Downloads” of the respective product ⇒ [7.2.2 Product Information](#).

7 Appendix

7.1 Ordering Information

Variants and Versions

Order Number	Brand Name	Description	MOQ ¹
ENW89853A1KF ²	PAN1762	Bluetooth Low Energy Module	1 500

¹ Abbreviation for Minimum Order Quantity (MOQ). The default MOQ for mass production is 1 500 pieces, fewer only on customer demand. Samples for evaluation can be delivered at any quantity via the distribution channels.

² Samples are available on customer demand.

7.2 Contact Details

7.2.1 Contact Us

Please contact your local Panasonic Sales office for details on additional product options and services:

For Panasonic Sales assistance in the **EU**, visit

<https://eu.industrial.panasonic.com/about-us/contact-us>

Email: wireless@eu.panasonic.com

For Panasonic Sales assistance in **North America**, visit the Panasonic “Sales & Support” website to find assistance near you at

<https://na.industrial.panasonic.com/distributors>

Please visit the **Panasonic Wireless Technical Forum** to submit a question at

<https://forum.na.industrial.panasonic.com>

7.2.2 Product Information

Please refer to the Panasonic Wireless Connectivity website for further information on our products and related documents:

For complete Panasonic product details in the **EU**, visit

<http://pideu.panasonic.de/products/wireless-modules.html>

For complete Panasonic product details in **North America**, visit

<http://www.panasonic.com/rfmodules>