

PAN1026A

Bluetooth® Basic Data Rate and Low Energy Module
Product Specification

Rev. 1.6

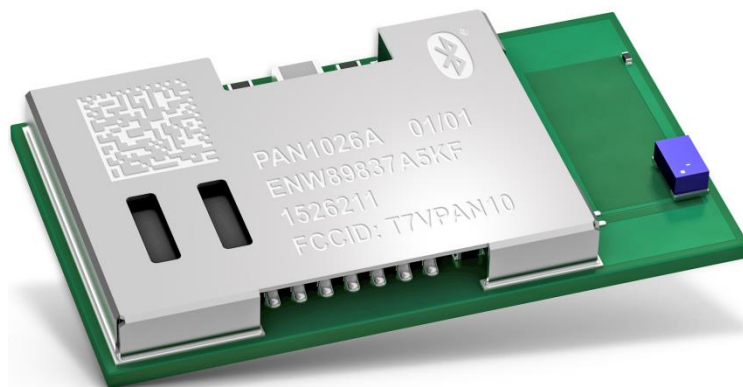

Overview

The PAN1026A is a Class 2 Bluetooth 4.2 Basic Data Rate and Low Energy module based on the Toshiba® TC35661 single-chip controller.

Features

- Small SMD module: 15.6 mm x 8.7 mm x 1.9 mm
- Same form factor as PAN1760A and PAN1762
- Bluetooth 4.2 Basic Data Rate and Low Energy compliant
- Bluetooth stack in ROM
- Embedded Basic Data Rate Serial Port Profile (SPP) profile
- Embedded Low Energy GATT profile
- Supported by Toshiba Bluetooth SDK
- UART, 10 General Purpose I/Os, wake up control pins

Bluetooth

- Basic Data Rate SPP profile
- Low Energy Peripheral and Broadcast support
- Low Energy GATT server and GATT client support
- Low Energy Central and Observer not supported

Basic Rate Features

- Faster SPP classic connection and disconnection times
- Support for interlaced inquiry and page scan
- Support for extended inquiry response

Low Energy Features

- Increased LE MTU size of 160 bytes
- Increased number of supported GATT services
- Increased number of supported GATT characteristics
- Support for TX power control
- Support for LE Secure Connections
- Improved peak error rate (PER)

Characteristics

- Typical sensitivity: -88 dBm
- Output power: max. 4 dBm
- Typical TX power consumption: 46 mA
- Voltage range: 2.7 V to 3.6 V (+/-10 %)
- Temperature range: -40 °C to +85 °C

Block Diagram

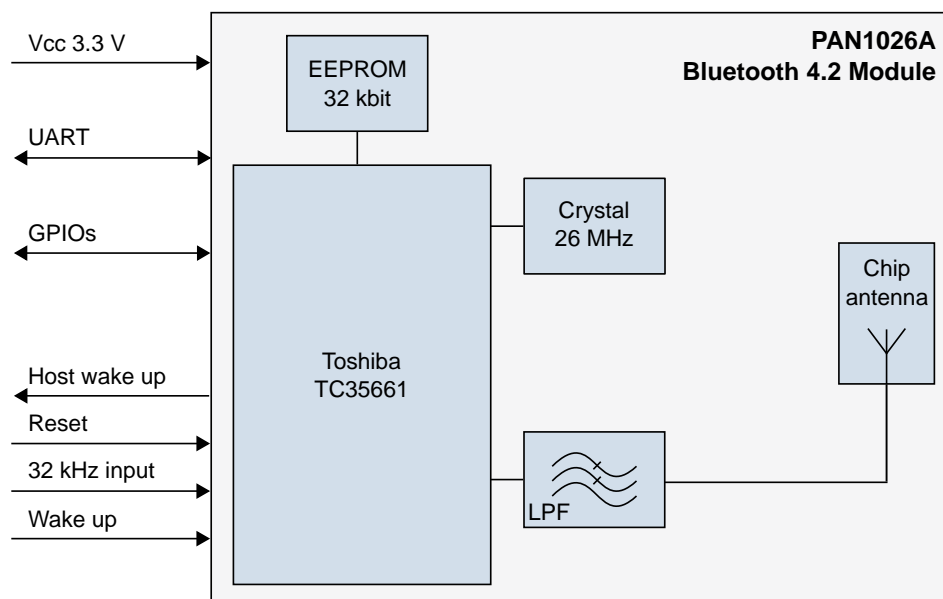

By purchase of any of the products described in this document the customer accepts the document's validity and declares their agreement and understanding of its contents and recommendations. Panasonic reserves the right to make changes as required at any time without notification. Please consult the most recently issued Product Specification before initiating or completing a design.

© Panasonic Industrial Devices Europe GmbH 2019.

This specification sheet is copyrighted. Reproduction of this document is permissible only if reproduction is without alteration and is accompanied by all associated warranties, conditions, limitations, and notices. Do not disclose it to a third party.

All rights reserved.

This Product Specification does not lodge the claim to be complete and free of mistakes.

Engineering Samples (ES)

If Engineering Samples are delivered to the customer, these samples have the status "Engineering Samples". This means that the design of this product is not yet concluded. Engineering Samples may be partially or fully functional, and they may differ from the published Product Specification.

Engineering Samples are not qualified and they are not to be used for reliability testing or series production.

Disclaimer

The customer acknowledges that samples may deviate from the Product Specification and may bear defects due to their status of development and the lack of qualification mentioned above.

Panasonic rejects any liability or product warranty for Engineering Samples. In particular, Panasonic disclaims liability for damages caused by:

The use of the Engineering Sample other than for evaluation purposes, particularly the installation or integration in another product to be sold by the customer,

Deviation or lapse in function of the Engineering Sample,

Improper use of the Engineering Sample.

Panasonic Industrial Devices Europe GmbH disclaims any liability for consequential and incidental damages. In case of any queries regarding the Engineering Samples, please contact your local sales partner or the related product manager.

Table of Contents

1	About This Document	5
1.1	Purpose and Audience	5
1.2	Revision History	5
1.3	Use of Symbols	5
1.4	Related Documents	5
2	Overview	6
2.1	Block Diagram	7
2.2	Pin Configuration	8
2.3	UART Interface.....	10
3	Detailed Description	11
3.1	Dimensions.....	11
3.2	Footprint	12
3.3	Packaging.....	13
3.4	Case Marking	16
4	Specification	17
4.1	Default Test Conditions	17
4.2	Absolute Maximum Ratings.....	17
4.3	Recommended Operating Conditions.....	18
4.4	Current Consumption.....	18
4.5	Bluetooth	19
4.6	Reliability Tests	19
4.7	Recommended Soldering Profile	20
5	Cautions	21
5.1	Design Notes	21
5.2	Installation Notes	21
5.3	Usage Condition Notes.....	22
5.4	Storage Notes.....	22
5.5	Safety Cautions	22
5.6	Other Cautions	23
5.7	Restricted Use	24
6	Regulatory and Certification Information	25
6.1	Federal Communications Commission (FCC) for US	25
6.2	Innovation, Science, and Economic Development (ISED) for Canada	27
6.3	Japanese Radio Law Compliance	29
6.4	European Conformity According to RED (2014/53/EU)	30
6.5	China (Label Requirements).....	31
6.6	Korea (Label Requirements).....	31
6.7	Bluetooth	32
6.8	RoHS and REACH Declaration	32
7	Appendix	33
7.1	Ordering Information.....	33
7.2	Contact Details	34

1 About This Document

1.1 Purpose and Audience

This Product Specification provides details on the functional, operational, and electrical characteristics of the Panasonic PAN1026A module.



It is intended for hardware design, application, and Original Equipment Manufacturers (OEM) engineers.

The product is referred to as “the PAN1026A” or “the module” within this document.

1.2 Revision History

Revision	Date	Modifications/Remarks
1.0	2017-08-08	1 st release version
1.1	2017-12-05	Added “MIC ID” to chapter “Regulatory and Certification Information”
1.2	2018-07-13	Added “QDIDs” to chapter “Regulatory and Certification Information”
1.3	2018-07-17	Overhauled chapter “Pin Configuration”
1.4	2019-02-12	Overhauled chapter “Pin Configuration”. Added chapter “China (Label Requirements)” and “Korea (Label Requirements)”.
1.5	2019-02-26	General editorial updates. Updated chapters “Block Diagram”, “Dimensions”, “Footprint”, “Cautions”. Updated formatting.
1.6	2019-03-25	Updated Bluetooth QDIDs.

1.3 Use of Symbols

Symbol	Description
	Note Indicates important information for the proper use of the product. Non-observance can lead to errors.
	Attention Indicates important notes that, if not observed, can put the product’s functionality at risk.
⇒ [chapter number] [chapter title]	Cross reference Indicates cross references within the document. Example: Description of the symbols used in this document ⇒ 1.3 Use of Symbols.

1.4 Related Documents

Please refer to the Panasonic website for related documents ⇒ [7.2.2 Product Information](#).

2 Overview

The PAN1026A is a Bluetooth 4.2 Basic Data Rate and Low Energy module based on the Toshiba TC35661 single-chip controller.

It has both a Bluetooth Basic Data Rate Serial Port Profile (SPP) and a Bluetooth Low Energy GATT profile stack integrated. Enhanced Data Rate (EDR) and GATT Central Mode are not supported.

Only one connection (either Bluetooth Basic Rate or Low Energy) at a time is supported, simultaneous operation of Bluetooth Basic Data Rate and Low Energy is not possible.

The integrated EEPROM is pre-programmed with a Bluetooth Device Address and can be used to store additional application information such as connection link keys.

Compared to the PAN1026, the PAN1026A is fully backwards compatible, but has additional support for increased MTU size, increased number of services and characteristics and now also supports LE Secure Connections.

The PAN1760A and PAN1762 modules have the same footprint.

Previously developed Bluetooth Low Energy profiles and applications can be easily migrated with a minimal effort.

Please refer to the Panasonic website for related documents ⇒ [7.2.2 Product Information](#).

Further information on the variants and versions ⇒ [7.1 Ordering Information](#).

2.1 Block Diagram

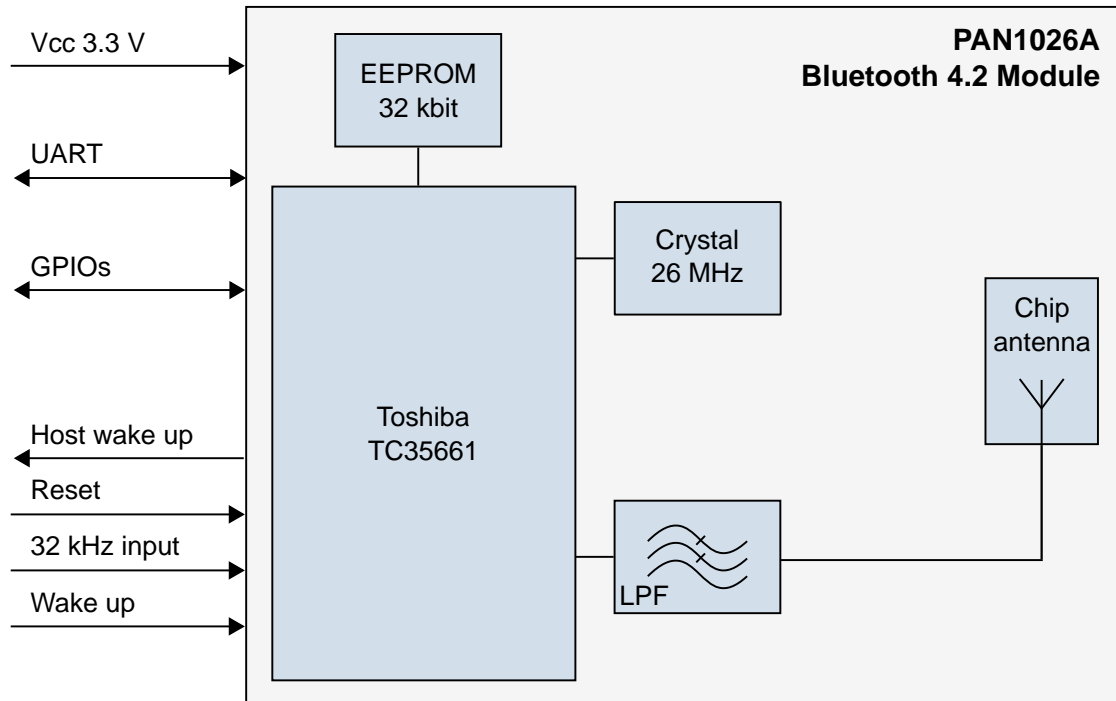

Total capacitor value: 6.7 μ F +/-10 %
 Total inductance: 2 nH +/-10 %
 Total resistance: 220 k Ω +/-10 %

2.2 Pin Configuration

Pin Assignment

Top View

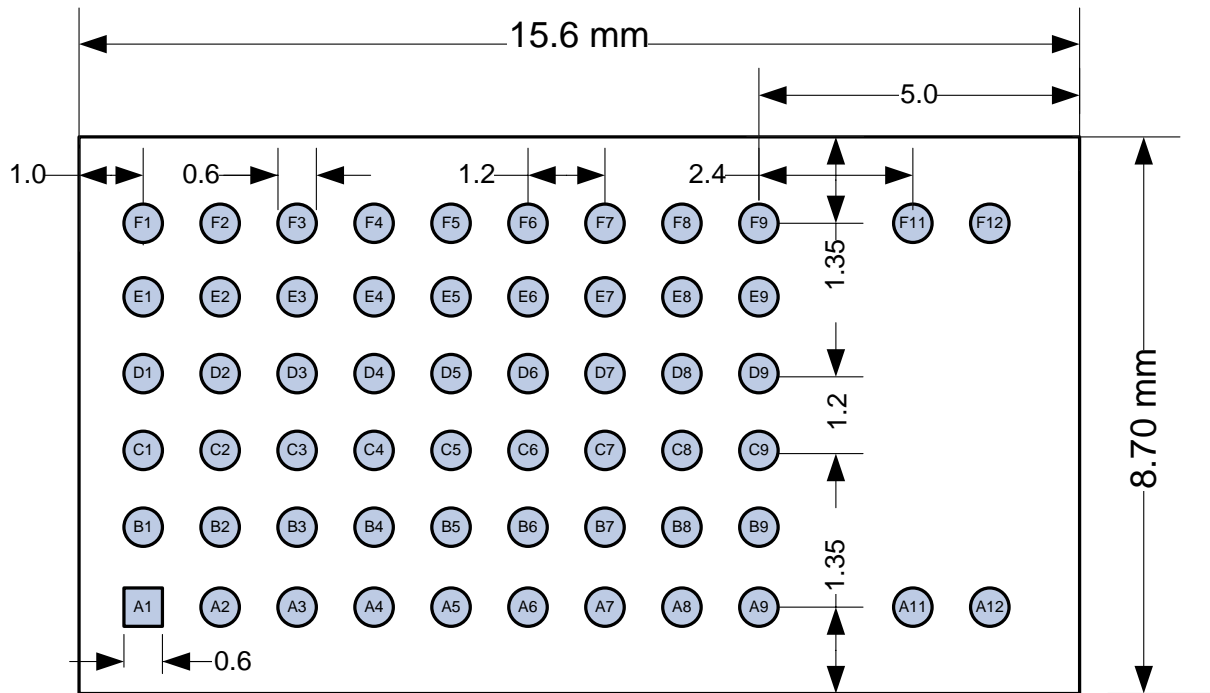

Pin Functions

No	Pin Name	Pin Type	Description
A1	GND	Ground Pin	Connect to ground
A2	NC	NC	Not connected, leave open
A3	Reset	Digital Input	Reset, active low
A4	VCC	Power	Analog/digital power supply connection
A5	VCC	Power	Analog/digital power supply connection
A6	VCC	Power	Analog/digital power supply connection
A7	GND	Ground Pin	Connect to ground
A8	NC	NC	Not connected
A9	GND	Ground Pin	Connect to ground
A11	GND	Ground Pin	Connect to ground
A12	GND	Ground Pin	Connect to ground

No	Pin Name	Pin Type	Description
B1	NC	NC	Not connected, leave open
B2	GPIO 11	Digital I/O	
B3	GPIO 10	Digital I/O	
B4	NC	NC	Not connected, leave open
B5	NC	NC	Not connected, leave open
B6	NC	NC	Not connected, leave open
B7	NC	NC	Not connected, leave open
B8	NC	NC	Not connected, leave open
B9	NC	NC	Not connected, leave open
C1	GPIO 17	Digital I/O	
C2	GPIO 13	Digital I/O	
C3	GPIO 12	Digital I/O	
C4	NC	NC	Not connected, leave open
C5	NC	NC	Not connected, leave open
C6	GPIO 04	Digital I/O	Commonly used for sleep mode "Host wake up" signal to host
C7	GPIO 05	Digital I/O	
C8	GND	Ground Pin	Connect to ground
C9	GND	Ground Pin	Connect to ground
D1	GPIO 18	Digital I/O	
D2	GPIO 16	Digital I/O	
D3	GPIO 01	Digital I/O	Commonly used for sleep mode "Status" signal to host
D4	GPIO 00	Digital I/O	Commonly used for sleep mode "Request wake up" signal from host
D5	NC	NC	Not connected, leave open
D6	GPIO 03	Digital I/O	
D7	GND	Ground Pin	Connect to ground
D8	GND	Ground Pin	Connect to ground
D9	ANT	RF-Signal	Antenna pin (not connected for standard version)
E1	SDA	Digital I/O	Internal I ² C interface, connect to test pin
E2	SCL	Digital I/O	Internal I ² C interface, connect to test pin
E3	GND	Ground Pin	Connect to ground
E4	NC	NC	Not connected, leave open
E5	CLKREQ	Digital Output	Active high once crystal frequency is stable
E6	UART RXD	Digital Input	UART RXD

No	Pin Name	Pin Type	Description
E7	GPIO 02	Digital I/O	
E8	GND	Ground Pin	Connect to ground
E9	GND	Ground Pin	Connect to ground
F1	GND	Ground Pin	Connect to ground
F2	EEPROM_WP	Digital Input	Internal EEPROM Write Protect (active high)
F3	GND	Ground Pin	Connect to ground
F4	GND	Ground Pin	Connect to ground
F5	UART CTS	Digital Input	UART CTS
F6	SLEEPCLK	Digital Input	Input clock for 32.768 KHz
F7	UARTTXD	Digital Output	UART TX
F8	UARTRTS	Digital Output	UART RTS
F9	GND	Ground Pin	Connect to ground
F11	GND	Ground Pin	Connect to ground
F12	GND	Ground Pin	Connect to ground

2.3 UART Interface

- Full-Duplex 4-wire data transfer: RX, TX, RTS, CTS
- Programmable baud rate: 2 400 bps to 4.33 Mbps
- Default baud rate: 115 200 bps
- Data format: 8N1, LSB first
- Error detection: Character timeout, Overrun error, Framing error

3 Detailed Description

3.1 Dimensions

 All dimensions are in millimeters.

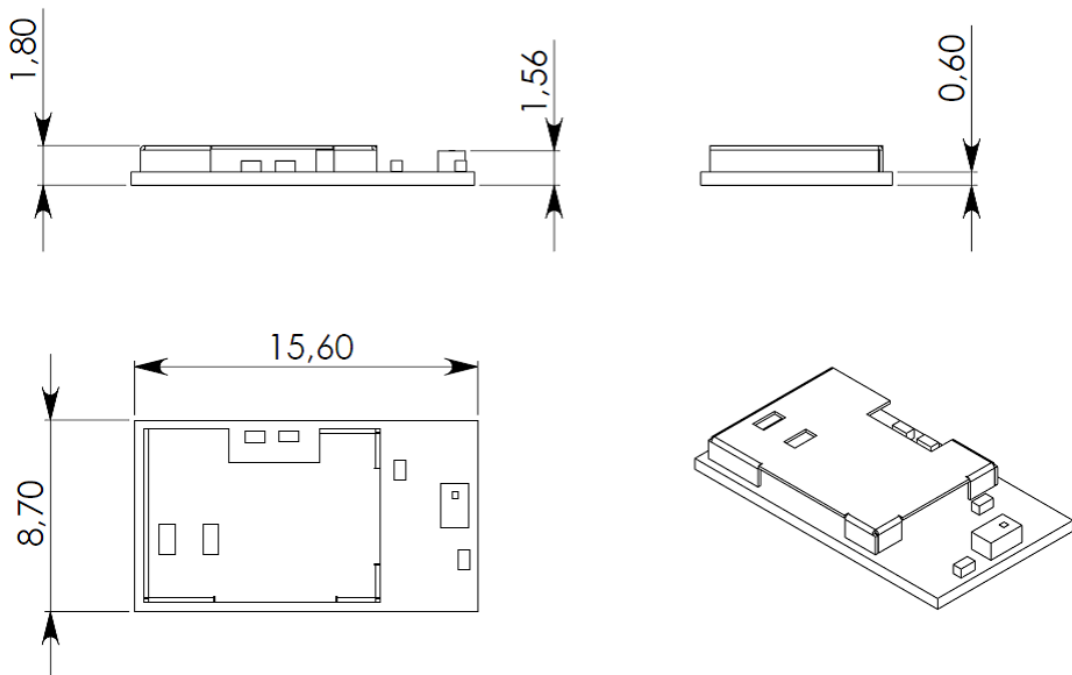

No.	Item	Dimension	Tolerance	Remark
1	Width	8.70	± 0.35	
2	Length	15.60	± 0.35	
3	Height	1.80	± 0.35	With case

3.2 Footprint

 The outer dimensions have a tolerance of ± 0.35 mm.

Top View

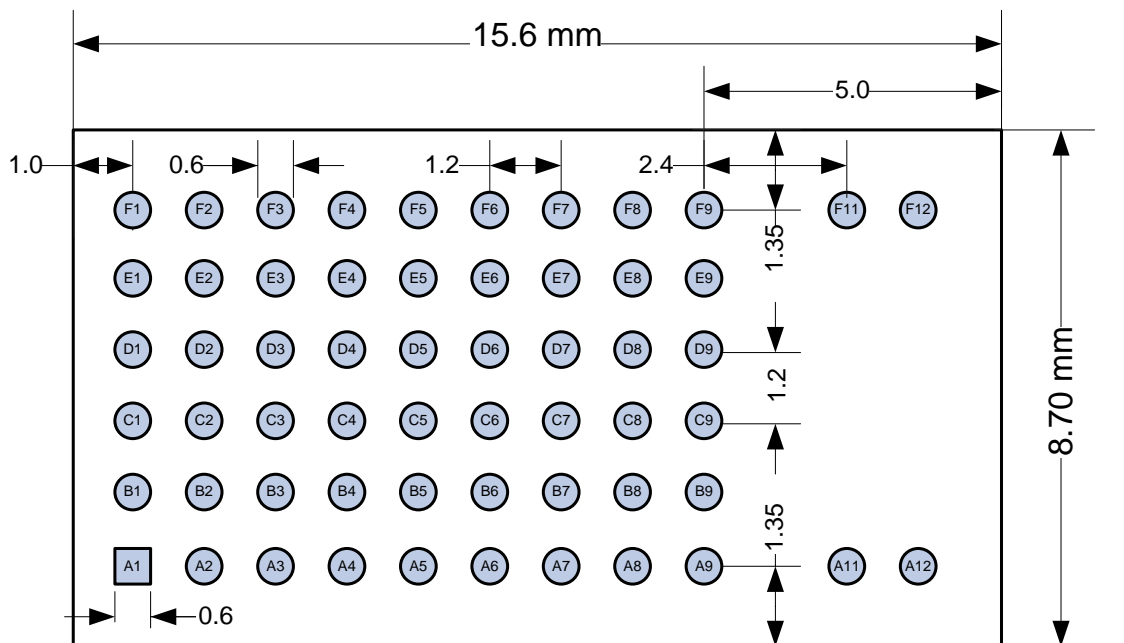

3.3 Packaging

The product is a mass production status product and will be delivered in the package described below.

3.3.1 Tape Dimensions

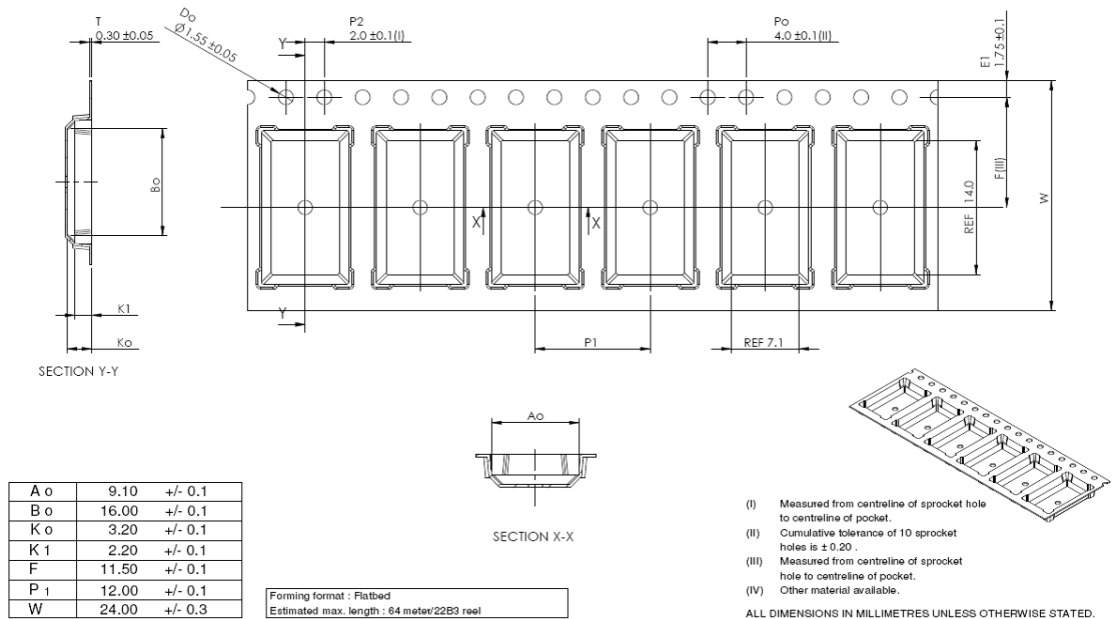

3.3.2 Packing in Tape

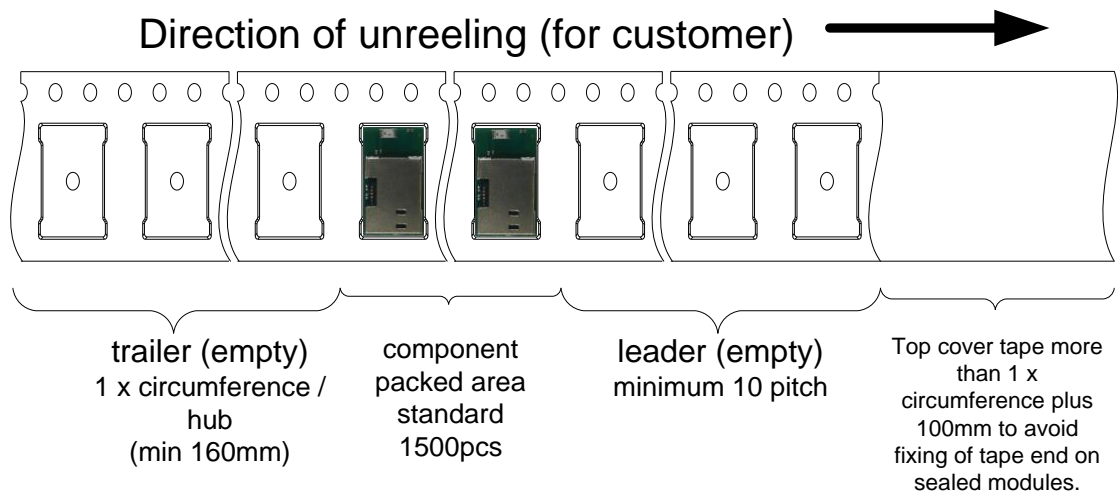

Empty spaces in the component packed area shall be less than two per reel and those spaces shall not be consecutive.

The top cover tape shall not be found on reel holes and it shall not stick out from the reel.

3.3.3 Component Direction

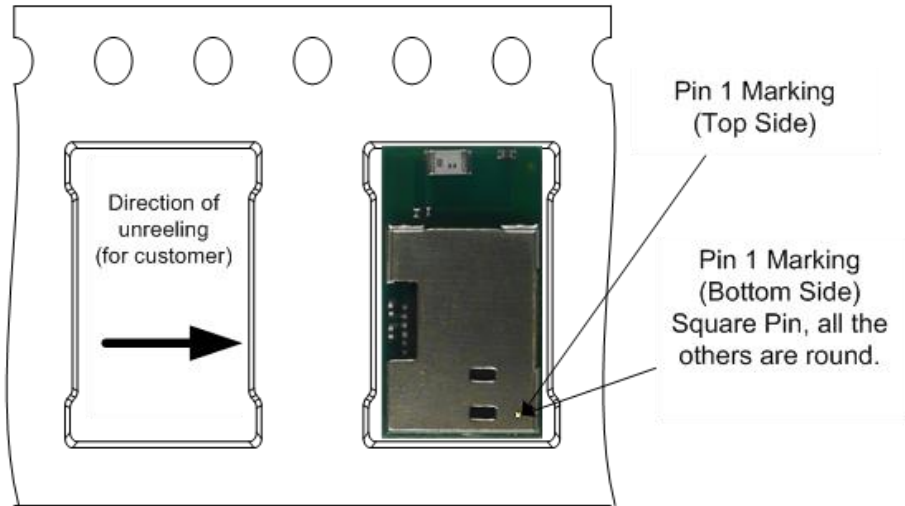

3.3.4 Reel Dimension

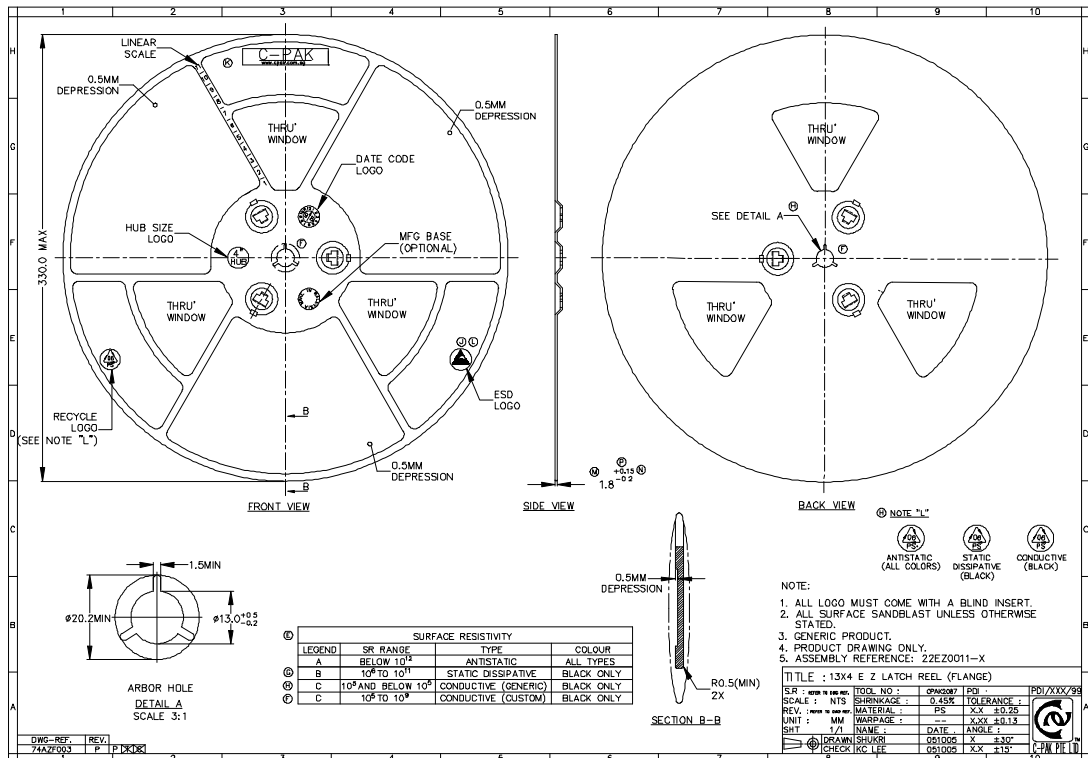

3.3.5 Package Label

Example

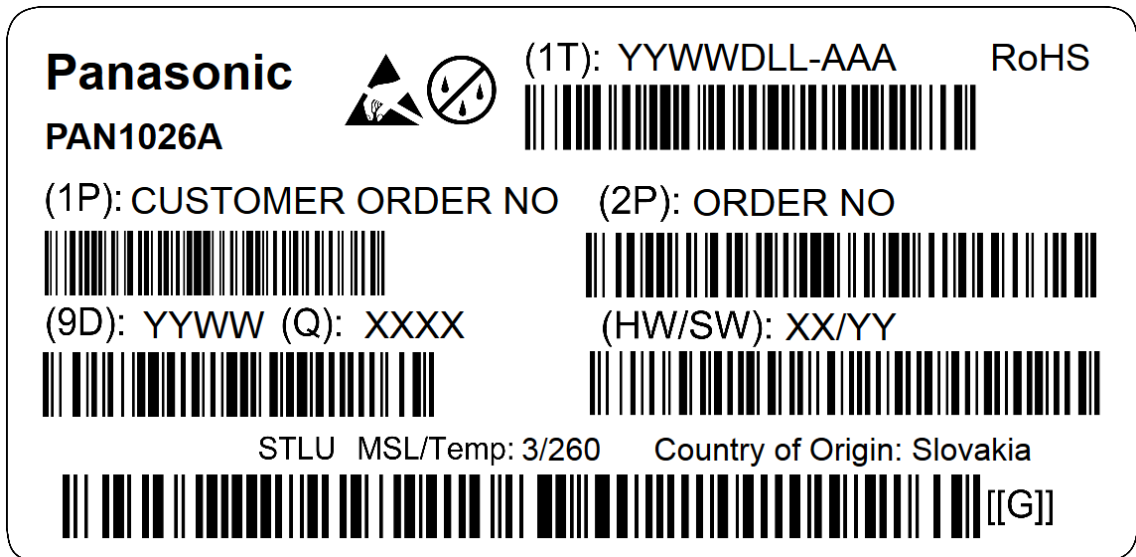

(1T)	Lot code
(1P)	Customer order number, if applicable
(2P)	Order number
(9D)	Date code
(Q)	Quantity
(HW/SW)	Hardware/software version

3.3.6 Total Package

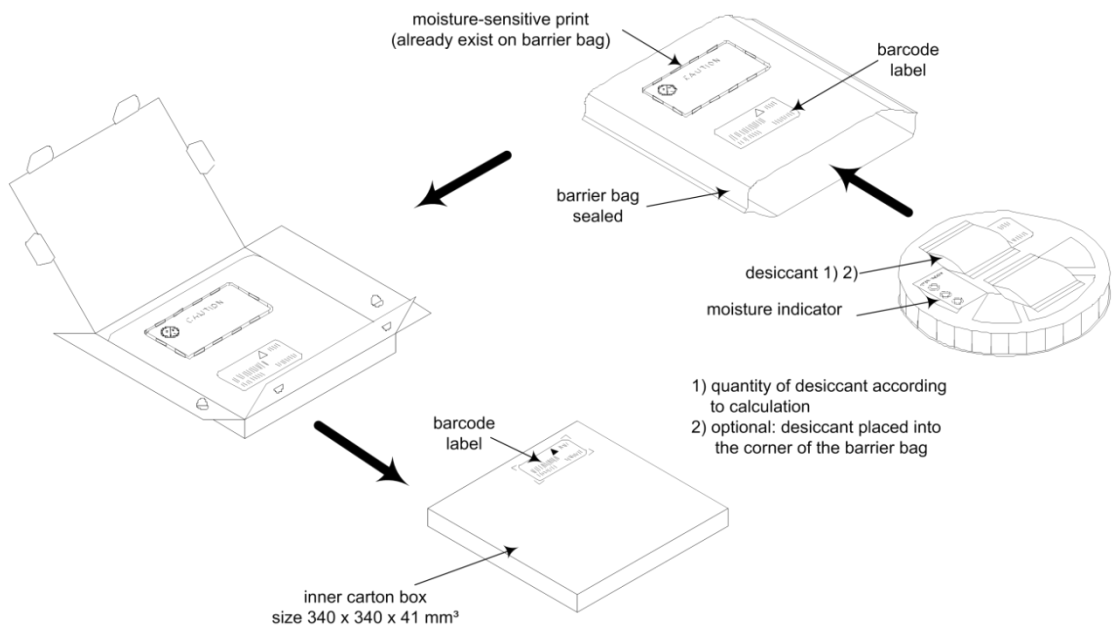

3.4 Case Marking

Example

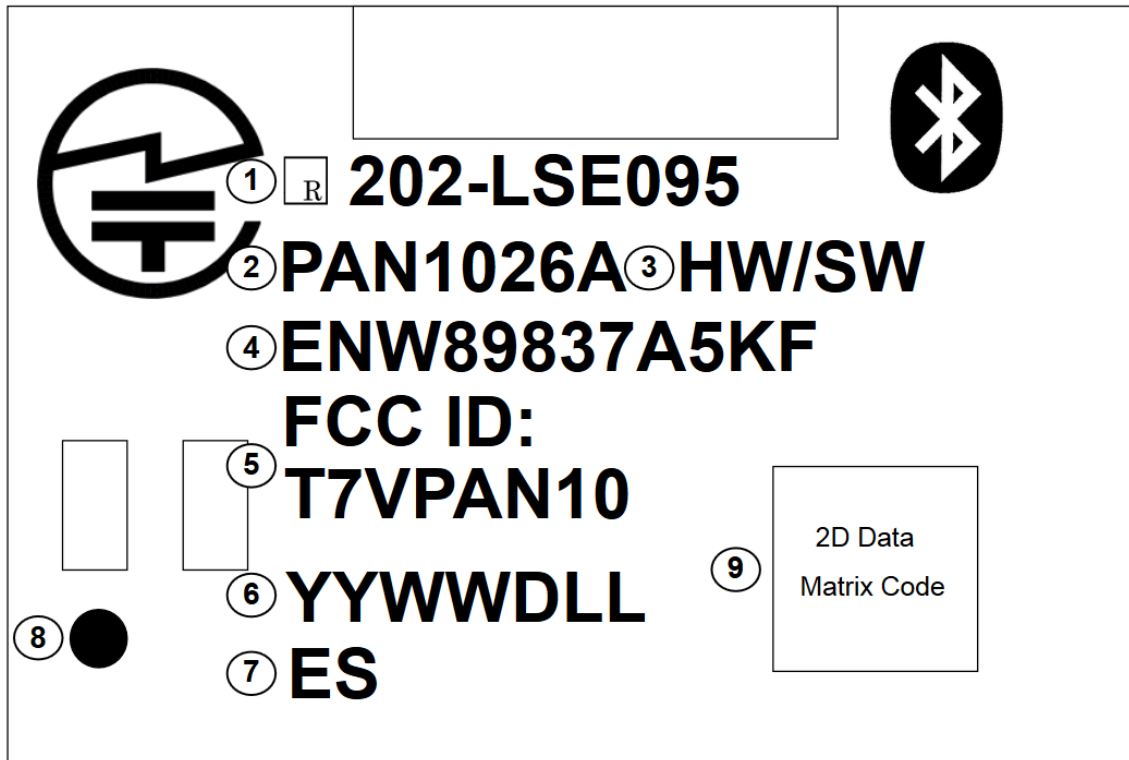

- 1 MIC ID
- 2 Brand name
- 3 Hardware/software version
- 4 Order number
- 5 FCC ID
- 6 Lot code
- 7 Engineering Sample marking, if applicable
- 8 Marking for Pin 1
- 9 2D barcode, for internal usage only

4 Specification



All specifications are over temperature and process, unless indicated otherwise.

4.1 Default Test Conditions



Temperature: $25 \pm 10 \text{ }^\circ\text{C}$
 Humidity: 40 to 85 % RH
 Supply Voltage: 3.3 V

4.2 Absolute Maximum Ratings



The maximum ratings may not be exceeded under any circumstances, not even momentarily or individually, as permanent damage to the module may result.

Symbol	Parameter	Condition	Min.	Typ.	Max.	Units
T _{STOR}	Storage temperature		-40		+125	°C
V _{ESD}	ESD robustness	All pads, according to human body model (HBM), JEDEC STD 22, method A114			1 000	V
		According to charged device model (CDM), JEDEC STD 22, method C101			500	V
P _{RF}	RF input level				+10	dBm
V _{DIG}	Voltage on any digital pins		-0.3		V _{DD} + 0.3	V

4.3 Recommended Operating Conditions



The maximum ratings may not be exceeded under any circumstances, not even momentarily or individually, as permanent damage to the module may result.

Symbol	Parameter	Condition	Min.	Typ.	Max.	Units
T _A	Ambient operating temperature range		-40		+85	°C
V _{DD}	3V3 Supply voltage		2.7	3.3	3.6	V

4.4 Current Consumption



The current consumption depends on the user scenario and on the setup and timing in the power modes.

Assume V_{DD} = 3.3 V, T_{amb} = 25 °C, if nothing else stated.

Parameter	Condition	Min.	Typ.	Max.	Units
Idle Current	After reset was pulled down.		7.8		mA
Connected Peak Power	Sending DH5 packets. Max. output power.			62	mA
Connected Peak Power	Sending DH3 packets. Max. output power.			61	mA
Connected Peak Power	Sending DH1 packets. Max. output power.			55	mA
Sleep Mode Activated	Sniff mode/not connected/LE Advertising		2		mA

4.5 Bluetooth

Parameter	Condition	Min.	Typ.	Max.	Units
Operation Frequency Range		2 402		2 480	MHz
Channel Spacing	Basic Data Rate		1		MHz
	Low Energy		2		
Output Power	Maximum setting, measured at chip output.	0	1	4	dBm
Sensitivity			-88		dBm

Symbol	Parameter	Condition	Min.	Typ.	Max.	Units
1	Spurious Emissions	Conducted measurement with a 50 Ω load. Complies with EN 300 328, EN 300 440 class 2, FCC CFR47, Part 15 and ARIB STD-T-66.		<-30		dBm

4.6 Reliability Tests

The measurement should be done after the test module has been exposed to room temperature and humidity for one hour.

No.	Item	Limit	Condition
1	Vibration test	Electrical parameter should be in specification	<ul style="list-style-type: none"> • Freq.: 10~50 Hz, Amplitude: 1.5 mm; 20 min./cycle, 1 hrs. each of XYZ axis • Freq.: 30~100 Hz, 6 G; 20 min./cycle, 1 hrs. each of XYZ axis
2	Shock test	See above	Dropped onto hard wood from a height of 50 cm for 3 times
3	Heat cycle test	See above	-40 °C for 30 min. and +85 °C for 30 min.; each temperature 300 cycles
4	Moisture test	See above	+60 °C, 90 % RH, 300 h
5	Low temperature test	See above	-40 °C, 300 h
6	High temperature test	See above	+85 °C, 300 h

4.7 Recommended Soldering Profile



- Reflow permissible cycles: 2
- Opposite side reflow is prohibited due to module weight
- More than 75 percent of the soldering area shall be coated by solder
- The soldering profiles should be adhered to in order to prevent electrical or mechanical damage
- Soldering profile assumes lead-free soldering

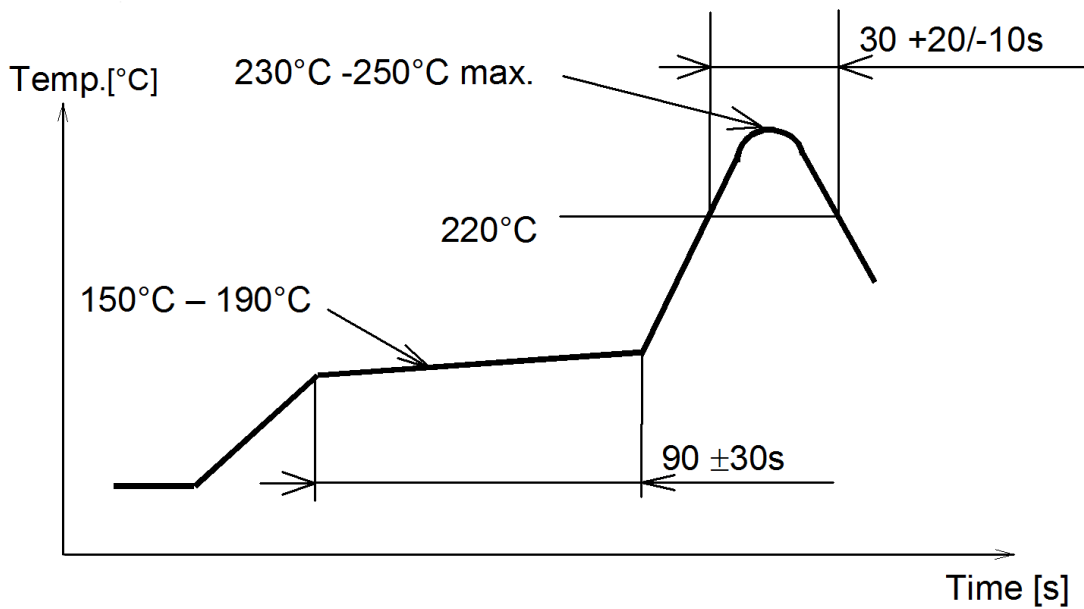

5 Cautions



Failure to follow the guidelines set forth in this document may result in degrading of the module functions and damage to the module.

5.1 Design Notes

1. Follow the conditions written in this specification, especially the control signals of this module.
2. The supply voltage should abide by the maximum ratings (⇒ [4.2 Absolute Maximum Ratings](#)).
3. The supply voltage must be free of AC ripple voltage (for example from a battery or a low noise regulator output). For noisy supply voltages, provide a decoupling circuit (for example a ferrite in series connection and a bypass capacitor to ground of at least 47 μF directly at the module).
4. This module should not be mechanically stressed when installed.
5. Keep this module away from heat. Heat is the major cause of decreasing the life time of these modules.
6. Avoid assembly and use of the target equipment in conditions where the module temperature may exceed the maximum tolerance.
7. Keep this module away from other high frequency circuits.
8. Refer to the recommended pattern when designing a board.

5.2 Installation Notes

1. Reflow soldering is possible twice based on the conditions set forth in ⇒ [4.7 Recommended Soldering Profile](#). Set up the temperature at the soldering portion of this module according to this reflow profile.
2. Carefully position the module so that the heat will not burn into printed circuit boards or affect other components that are susceptible to heat.
3. Carefully locate the module, to avoid an increased temperature caused by heat generated by neighboring components.
4. If a vinyl-covered wire comes into contact with the module, the wire cover will melt and generate toxic gas, damaging the insulation. Never allow contact between a vinyl cover and these modules to occur.
5. This module should not be mechanically stressed or vibrated when reflowed.
6. To repair the board by hand soldering, follow the conditions set forth in this chapter.
7. Do not wash this product.
8. Pressing on parts of the metal cover or fastening objects to the metal will cause damage to the module.

5.3 Usage Condition Notes

1. Take measures to protect the module against static electricity.
If pulses or transient loads (a large load, which is suddenly applied) are applied to the modules, check and evaluate their operation before assembly of the final products.
2. Do not use dropped modules.
3. Do not touch, damage, or soil the pins.
4. Follow the recommended condition ratings about the power supply applied to this module.
5. Electrode peeling strength: Do not apply a force of more than 4.9 N in any direction on the soldered module.
6. Pressing on parts of the metal cover or fastening objects to the metal cover will cause damage.
7. These modules are intended for general purpose and standard use in general electronic equipment, such as home appliances, office equipment, information, and communication equipment.

5.4 Storage Notes

1. The module should not be stressed mechanically during storage.
2. Do not store these modules in the following conditions or the performance characteristics of the module, such as RF performance will be adversely affected:
 - Storage in salty air or in an environment with a high concentration of corrosive gas, such as Cl₂, H₂S, NH₃, SO₂, or NO_x,
 - Storage in direct sunlight,
 - Storage in an environment where the temperature may be outside the range of 5 °C to 35 °C, or where the humidity may be outside the 45 % to 85 % range,
 - Storage of the modules for more than one year after the date of delivery storage period: Please check the adhesive strength of the embossed tape and soldering after 6 months of storage.
3. Keep this module away from water, poisonous gas, and corrosive gas.
4. This module should not be stressed or shocked when transported.
5. Follow the specification when stacking packed crates (max. 10).

5.5 Safety Cautions

These specifications are intended to preserve the quality assurance of products and individual components.

Before use, check and evaluate the operation when mounted on your products. Abide by these specifications without deviation when using the products. These products may short-circuit. If electrical shocks, smoke, fire, and/or accidents involving human life are anticipated when a short circuit occurs, provide the following failsafe functions as a minimum:

1. Ensure the safety of the whole system by installing a protection circuit and a protection device.
2. Ensure the safety of the whole system by installing a redundant circuit or another system to prevent a single fault causing an unsafe status.

5.6 Other Cautions

1. Do not use the module for other purposes than those listed in section ⇒ [5.3 Usage Condition Notes](#).
2. Be sure to provide an appropriate fail-safe function on your product to prevent any additional damage that may be caused by the abnormal function or the failure of the module.
3. This module has been manufactured without any ozone chemical controlled under the Montreal Protocol.
4. These modules are not intended for use under the special conditions shown below. Before using these modules under such special conditions, carefully check their performance and reliability under the said special conditions to determine whether or not they can be used in such a manner:
 - In liquid, such as water, salt water, oil, alkali, or organic solvent, or in places where liquid may splash,
 - In direct sunlight, outdoors, or in a dusty environment,
 - In an environment where condensation occurs,
 - In an environment with a high concentration of harmful gas (e. g. salty air, HCl, Cl₂, SO₂, H₂S, NH₃, and NO_x).
5. If an abnormal voltage is applied due to a problem occurring in other components or circuits, replace these modules with new modules, because they may not be able to provide normal performance even if their electronic characteristics and appearances appear satisfactory.



Please refer to the Panasonic website for further information
⇒ [7.2.2 Product Information](#).

5.7 Restricted Use

5.7.1 Life Support Policy

This Panasonic Industrial Devices Europe GmbH product is not designed for use in life support appliances, devices, or systems where malfunction can reasonably be expected to result in a significant personal injury to the user, or as a critical component in any life support device or system whose failure to perform can be reasonably expected to cause the failure of the life support device or system, or to affect its safety or effectiveness.

Panasonic customers using or selling these products for use in such applications do so at their own risk and agree to fully indemnify Panasonic Industrial Devices Europe GmbH for any damages resulting.

5.7.2 Restricted End Use

This Panasonic Industrial Devices Europe GmbH product is not designed for any restricted activity that supports the development, production, handling usage, maintenance, storage, inventory or proliferation of any weapons or military use.

Transfer, export, re-export, usage or reselling of this product to any destination, end user or any end use prohibited by the European Union, United States or any other applicable law is strictly prohibited.

6 Regulatory and Certification Information

6.1 Federal Communications Commission (FCC) for US

6.1.1 FCC Notice



The PAN1026A including the antennas, which are listed in [⇒ 6.1.5 Approved Antenna List](#), complies with Part 15 of the FCC Rules.

The PAN1026A meets the requirements for modular transmitter approval as detailed in FCC public Notice DA00-1407. The transmitter operation is subject to the following two conditions:

1. The module may not cause harmful interference, and
2. The module must accept any interference received, including interference that may cause undesired operation.

6.1.2 Caution



The FCC requires the user to be notified that any changes or modifications made to this module that are not expressly approved by Panasonic Industrial Devices Europe GmbH may void the user's authority to operate the PAN1026A.



This module has been tested and found to comply with the limits for a Class B digital device, pursuant to Part 15 of the FCC Rules.

These limits are designed to provide reasonable protection against harmful interference in a residential installation. This module generates uses and can radiate radio frequency energy and, if not installed and used in accordance with the instructions, may cause harmful interference to radio communications.

However, there is no guarantee that interference will not occur in a particular installation. If this module does cause harmful interference to radio or television reception, which can be determined by turning the equipment off and on, the user is encouraged to try to correct the interference by one or more of the following measures:

- Reorient or relocate the receiving antenna.
- Increase the separation between the module and receiver.
- Connect the PAN1026A into an outlet on a circuit different from that to which the receiver is connected.
- Consult the dealer or an experienced radio/TV technician for help

6.1.3 Label Requirements



The OEM must ensure that FCC labelling requirements are met. This includes a clearly visible label on the outside of the OEM enclosure specifying the appropriate Panasonic FCC identifier for this module as well as the FCC Notice above.

The FCC identifier is **FCC ID: T7VPAN10**.

This FCC identifier is valid for the PAN1026A. The end product must in any case be labelled on the exterior with:

"Contains FCC ID: T7VPAN10"

6.1.4 Antenna Warning

This antenna warning refers to the tested module with the model number PAN1026A

⇒ [7.1 Ordering Information](#)

The module is tested with a standard SMA connector and with the antenna listed below. When integrated into the OEM's product, these fixed antennas require installation preventing end users from replacing them with non-approved antennas. Any antenna not in the following table must be tested to comply with FCC Section 15.203 for unique antenna connectors and with Section 15.247 for emissions. The FCC identifier for the PAN1026A with the antenna listed in ⇒ [6.1.5 Approved Antenna List](#) is the same (**FCC ID: T7VPAN10**).

6.1.5 Approved Antenna List

Item	Part Number	Manufacturer	Frequency Band	Type	Gain (dBi)
1	LDA212G3110K	Murata	2.4 GHz	Chip Antenna	+0.9
2	ANT2012	Yageo	2.4 GHz	Chip Antenna	+0.9

6.1.6 RF Exposure



To comply with FCC RF Exposure requirements, the OEM must ensure that only antennas from the Approved Antenna List are installed ⇒ [6.1.5 Approved Antenna List](#).

The preceding statement must be included as a CAUTION statement in manuals for products operating with the approved antennas in the previous table to alert users on FCC RF Exposure compliance.

Any notification to the end user containing installation or removal instructions regarding the integrated radio module is not allowed.

The radiated output power of the PAN1026A with a mounted ceramic antenna (**FCC ID: T7VPAN10**) is below the FCC radio frequency exposure limits. Nevertheless, the PAN1026A shall be used in such a manner that the potential for human contact during normal operation is minimized.

End users may not be provided with the module installation instructions. OEM integrators and end users must be provided with transmitter operating conditions for satisfying RF exposure compliance.

6.2 Innovation, Science, and Economic Development (ISED) for Canada

English

The PAN1026A is licensed to meet the regulatory requirements of Industry Canada (IC).

License ID: **IC: 216Q-PAN10**

Manufacturers of mobile, fixed or portable devices incorporating this module are advised to clarify any regulatory questions and ensure compliance for SAR and/or RF exposure limits. Users can obtain Canadian information on RF exposure and compliance from www.ic.gc.ca.

The PAN1026A has been designed to operate with the antennas listed in ⇒ [6.1.5 Approved Antenna List](#), having a maximum gain of +0.9 dBi. Antennas not included in this list or having a gain greater than +0.9 dBi are strictly prohibited for use with this module. The required antenna impedance is 50 Ω. The antenna used for this transmitter must not be co-located or operating in conjunction with any other antenna or transmitter.

Due to the module size, the IC identifier is displayed in the installation instruction only and it cannot be displayed on the module's label due to the limited size.

French

PAN1026A est garanti conforme aux dispositions réglementaires d'Industry Canada (IC).

License: **IC: 216Q-PAN10**

Il est recommandé aux fabricants d'appareils fixes, mobiles ou portables de consulter la réglementation en vigueur et de vérifier la conformité de leurs produits relativement aux limites d'exposition aux rayonnements radiofréquence ainsi qu'au débit d'absorption spécifique maximum autorisé.

Des informations pour les utilisateurs sur la réglementation Canadienne concernant l'exposition aux rayonnements RF sont disponibles sur le site www.ic.gc.ca.

Ce produit a été développé pour fonctionner spécifiquement avec les antennes listées dans le tableau ⇒ [6.1.5 Approved Antenna List](#), présentant un gain maximum de 0.9 dBi. Des antennes autres que celles listées ici, ou présentant un gain supérieur à 0.9 dBi ne doivent en aucune circonstance être utilisées en combinaison avec ce produit. L'impédance des antennes compatibles est 50 Ohm. L'antenne utilisée avec ce produit ne doit ni être située à proximité d'une autre antenne ou d'un autre émetteur, ni être utilisée conjointement avec une autre antenne ou un autre émetteur.

En raison de la taille du produit, l'identifiant IC est fourni dans le manuel d'installation.

6.2.1 IC Notice

English



The PAN1026A (⇒ [7.1 Ordering Information](#)), including the antennas (⇒ [6.1.5 Approved Antenna List](#)), complies with Canada RSS-GEN Rules. The PAN1026A meets the requirements for modular transmitter approval as detailed in RSS-Gen.

Operation is subject to the following two conditions:

1. This module may not cause harmful interference, and
2. This module must accept any interference received, including interference that may cause undesired operation.

French



Le présent appareil PAN1026A (⇒ [7.1 Ordering Information](#)), les antennes y compris (⇒ [6.1.5 Approved Antenna List](#)), est conforme aux CNR-Gen d'Industrie Canada applicables aux appareils radio exempts de licence.

L'exploitation est autorisée aux deux conditions suivantes :

1. L'appareil ne doit pas produire de brouillage, et
2. L'utilisateur de l'appareil doit accepter tout brouillage radioélectrique subi, même si le brouillage est susceptible d'en compromettre le fonctionnement.

6.2.2 Labeling Requirements

English



Labeling Requirements

The OEM must ensure that IC labelling requirements are met. This includes a clearly visible label on the outside of the OEM enclosure specifying the appropriate Panasonic IC identifier for this module as well as the IC Notice above.

The IC identifier is:

IC: 216Q-PAN10

This IC identifier is valid for all PAN1026A modules ⇒ [7.1 Ordering Information](#). In any case, the end product must be labelled on the exterior with:

"Contains IC: 216Q-PAN10".

French



Obligations d'étiquetage

Les fabricants d'équipements d'origine (FEO) – en anglais Original Equipment Manufacturer (OEM) – doivent s'assurer que les obligations d'étiquetage IC du produit final sont remplies. Ces obligations incluent une étiquette clairement visible à l'extérieur de l'emballage externe, comportant l'identifiant IC du module Panasonic inclus, ainsi que la notification ci-dessus.

L' identifiant IC est:

IC: 216Q-PAN10

Cet identifiant est valide pour tous les modules PAN1026A ⇒ [7.1 Ordering Information](#). Dans tous les cas les produits finaux doivent indiquer sur leur emballage externe la mention suivante:

"Contient IC: 216Q-PAN10".

6.3 Japanese Radio Law Compliance

This module is granted pursuant to the Japanese Radio Law (電波法).

The module should not be modified (otherwise the granted designation number will become invalid).

The MIC ID is: 202-LSE095

6.4 European Conformity According to RED (2014/53/EU)

All modules described in this Product Specification comply with the standards according to the following LVD (2014/35/EU), EMC-D (2014/30/EU) together with the RED (2014/53/EU) articles:

3.1a Safety/Health: EN60950-1:2006+A11:2009+A1:2010+A12:2011+AC:2011+A2:2013
EN62311:2008

3.1b EMC: EN 301 489-1 V2.1.1:2017-02
EN 301 489-17 V3.1.1:2017-02

3.2 Radio: EN 300 328 V2.1.1:2016-11

As a result of the conformity assessment procedure described in the 2014/53/EU Directive, the end customer equipment should be labelled as follows:



PAN1026A in the specified reference design can be used in all countries of the European Economic Area (Member States of the EU, European Free Trade Association States [Iceland, Liechtenstein, Norway]), Monaco, San Marino, Andorra and Turkey.

6.5 China (Label Requirements)



The OEM must ensure that CCC labelling requirements are met. This includes a clearly visible label on the outside of the OEM enclosure specifying the appropriate Panasonic CCC identifier for this module.

The final Bluetooth product must be marked with an approval code, known as the “China MII ID”, product name, model number, and battery information, place of production, manufacturer name, and CMIIT number.

Format of the ID is as follows: “**CMIIT ID: 2018DJ06806**”, where:

- **CMIIT**: Abbreviation for China Ministry of Information Industry
- **2018**: Year of application
- **DJ**: Code indicating equipment category
- **06806**: Approval serial number issued by SRRC

Labelling Example:

Panasonic Industrial Devices Europe GmbH

Model: PAN1026A

CMITT ID: 2018DJ06806

6.6 Korea (Label Requirements)



The OEM must ensure KC marking requirements. The integrator of the module should refer to the labeling requirements for Korea available on the Korea Communications Commission (KCC) website.

The module is not labeled with its own KC mark. The final product requires the KC mark and MSIP certificate number of the module:

Format of the ID is as follows: “**MSIP: R-C-Pid-PAN1026A**”, where

- **MSIP**: Ministry of Science, ICT & Future Planning
- **R**: Indication of Broadcasting Communication Equipment code
- **C**: Indication of Basic Certification Information
- **Pid**: Indication of Application Information
- **PAN1026A**: Indication of Product

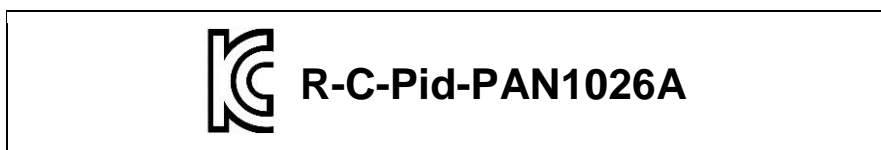
Labelling Example:**For more details please visit:**

Korea Communications Commission (KCC)

<http://www.kcc.go.kr>

National Radio Research Agency (RRA)

<http://rra.go.kr>

6.7 Bluetooth

The final Bluetooth product needs to be created by using the following IDs:

Declaration ID	QDID	Company	Products	Specification Name	Listing Date
D034524	93268 - Component (Tested)	Toshiba Corporation	Toshiba Bluetooth TC35661-551, TC35661-551	4.2	2017-05-02
D030433	89458 - Component (Tested)	Toshiba Corporation	Toshiba Bluetooth TC35661, [...] TC35661-551, TC35661-551	4.2	2016-11-28

6.8 RoHS and REACH Declaration

The latest declaration of environmental compatibility (Restriction of Hazardous Substances, RoHS and Registration, Evaluation, Authorisation, and Restriction of Chemicals, REACH) for supplied modules can be found on the Panasonic website in the “Downloads” section of the respective module ⇒ [7.2.2 Product Information](#).

7 Appendix

7.1 Ordering Information

Variants and Versions

Order Number	Brand Name	Description	MOQ ¹
ENW89837A5KF ²	PAN1026A	Bluetooth 4.2 Basic Data Rate and Low Energy module	1 500

¹ Abbreviation for Minimum Order Quantity (MOQ). The default MOQ for mass production is 1 500 pieces, fewer only on customer demand. Samples for evaluation can be delivered at any quantity via the distribution channels.

² Samples are available on customer demand.

7.2 Contact Details

7.2.1 Contact Us

Please contact your local Panasonic Sales office for details on additional product options and services:

For Panasonic Sales assistance in the **EU**, visit

<https://eu.industrial.panasonic.com/about-us/contact-us>

Email: wireless@eu.panasonic.com

For Panasonic Sales assistance in **North America**, visit the Panasonic website “Sales & Support” to find assistance near you at

<https://na.industrial.panasonic.com/distributors>

Please visit the **Panasonic Wireless Technical Forum** to submit a question at

<https://forum.na.industrial.panasonic.com>

7.2.2 Product Information

Please refer to the Panasonic Wireless Connectivity website for further information on our products and related documents:

For complete Panasonic product details in the **EU**, visit

<http://pideu.panasonic.de/products/wireless-modules.html>

For complete Panasonic product details in **North America**, visit

<http://www.panasonic.com/rfmodules>